

Vive PowPak Dimming Module with 0–10 V_{DC} Control

The PowPak Dimming Module with 0–10 V_{DC} Control is a radio frequency (RF) control that operates 0–10 V_{DC} controlled fluorescent ballasts or LED drivers based on input from Pico remote controls and Radio Powr Savr sensors. The Dimming Module with 0–10 V_{DC} Control is ideal for small areas (e.g., classrooms, conference rooms, private offices).

Communication with RF input devices (e.g., Pico remote controls, Radio Powr Savr sensors) is accomplished by using Lutron Clear Connect RF Technology.

These products are also compatible with the Vive hub which enables a simple setup process using a standard web browser on any Wi-Fi enabled phone, tablet or computer. It also enables control and monitoring of all Vive devices. The Vive hub can be added at any time. System reprogramming will be required. For a complete list of features supported with the Vive hub, see specification submittal 369902 at www.lutron.com

Note for Replacement: RMJS/URMJS - the “S” model can replace the non-“S” model.

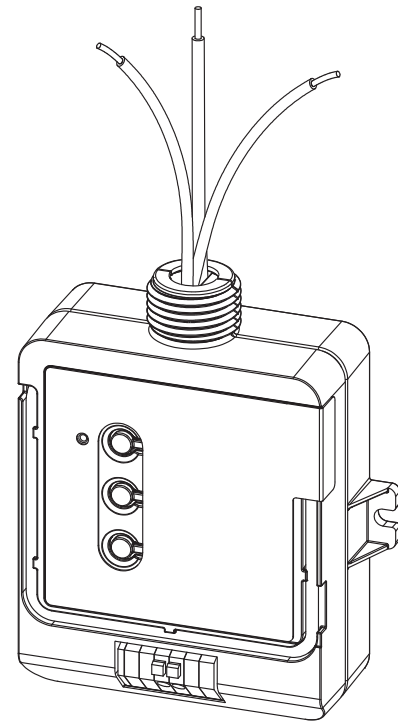

RMJS-8T-DV-B (shown)

Features

- Controls up to 60 mA of 0–10 V_{DC} controlled fixtures together
- New model available for use with emergency lighting¹
- Switches up to 8 A total
- 0–10 V_{DC} control link automatically sources or sinks to the third party fixtures
- Configurable high- and low-end trim
- Various operating voltages available; refer to model number chart on the next page for details on voltage requirements
- Receives wireless inputs from up to 10 Pico remote controls, 10 Radio Powr Savr occupancy/vacancy sensors, and 1 Radio Powr Savr daylight sensor
- Utilizes Lutron Clear Connect RF Technology; refer to model number chart on the next page for frequency band data
- Mounts to the exterior of a US-style junction box through a standard-size knockout

¹ For systems with backup emergency generators only.

Job Name:	Model Numbers:
Job Number:	

Models

Model Number	Region	Operating Voltage	Frequency Band
RMJS-8T-DV-B	U.S.A., Canada, Mexico	120/277 V~	431.0–437.0 MHz
URMJS-8T-DV-B	U.S.A. (BAA Compliant)	120/277 V~	431.0–437.0 MHz
RMJS-8TN-DV-B	U.S.A., Canada, Mexico	120/277 V~	431.0–437.0 MHz
RMJS-8T-DV-B-EM	U.S.A., Canada, Mexico	120/277 V~	431.0–437.0 MHz

NOTE: Contact Lutron for frequency band compatibility for your geographic region if it is not indicated above.

Job Name:	Model Numbers:
Job Number:	

Specifications

Regulatory Approvals

- UL® Listed
- UL 924 Listed (RMJS-8T-DV-B-EM only)
- FCC approved. Complies with the limits for a Class B device, pursuant to Part 15 of the FCC rules
- Complies with requirements for use in other spaces used for environmental air (plenums) per NEC® 2014 300.22(C)(3)
- Listed in accordance to CAN/ULC S102.2-2010 with a Flame Spread Rating of 0 and a Smoke Developed Classification of 40, with a minimum spacing of 6 ft (1.83 m) off center
- cUL and IC (Canada) (RMJS- only)
- COFETEL (Mexico) (RMJS- only)
- NOM (Mexico) (RMJS- only)

Power

- Operating voltage
120/277 V~ 50/60 Hz

Output Ratings

- Switch rating of 8 A. Rated for resistive or capacitive loads as defined by IEC/EN 60669-2-1
- 0–10 V== control link for 60 mA maximum output, source or sink automatically configures

Other Power Specifications

- Standby power:
 - 240–277 V~ 610 mW
 - 120 V~ 550 mW
- BTU/hour when fully loaded: 9
- Works with all ballasts and drivers that provide a current source that is compliant to IEC 60629 Annex E.2, and whose inrush current does not exceed NEMA410 standards for electronic ballast/driver

Mounting

- This device can be installed on a junction box or marshalling box using the conduit nut or with mounting screws. The device must NOT be mounted inside a metallic enclosure – only on the exterior of a junction box, or marshalling box. Improper installation can result in degraded wireless communications and intermittent or sustained communications failures and will not be covered under warranty. For applications (in U.S.A.) where code requires the PowPak control to be installed inside an additional junction box, please see Lutron Application Note #423 (P/N 048423) at www.lutron.com for how to perform this installation. For all other installations, refer to the installation instructions and consult local and national electric codes for proper installation. The PowPak control needs to be accessible for some programming steps. Record where it is mounted of that it can be easily located later.

System Communication

- Operates using Clear Connect RF Technology for reliable wireless communication; refer to model number chart on page 1 for frequency band details
- RF range is 30 ft (9 m)
- Wireless sensors and controls must be located within 60 ft (18 m) line of sight, or 30 ft (9 m), through walls, of the associated control module. The 60 ft (18 m) range is not reduced by a ceiling tile obstruction.

Environment

- Ambient operating temperature: 32 °F to 104 °F (0 °C to 40 °C)
- 0% to 90% humidity, non-condensing
- For indoor use only
- All drivers and ballasts used with Vive wireless controls must comply with the limits for a Class A device pursuant to Part 15 of the FCC Rules

(continued on next page . . .)

<p>Job Name:</p> <p>Job Number:</p>	<p>Model Numbers:</p>
--	-----------------------

Specifications *(continued)*

0–10 V_{DC} Control Link

- Communicates with up to 60 mA of fixtures
- Control link is IEC SELV/NEC® Class 2
- 0–10 V_{DC} control can be installed using NEC® Class 1 or Class 2 wiring methods. Alternately, it can be wired to basic or double-insulated devices
- Always consult local wiring codes
- Compatible with ANSI E1.3 2001 (R2006), IEC 60929 Annex E

Emergency Model Sequence of Operation

With a Vive hub:

- **Normal mode:** The RMJS-8T-DV-B-EM can dim loads as normal and respond to local button presses, Pico wireless controls, and occupancy/daylight sensors.
- If the emergency PowPak loses power for greater than 250 mS, it will automatically go into emergency mode (full output, relay closed), when emergency power is restored to the PowPak, for as long as the Vive hub has no power. All local buttons, Pico wireless controls and occupancy/daylight sensors will not respond. The emergency light level of the emergency PowPak can be configured using the Vive hub.
- When normal power is restored to the Vive hub and emergency PowPak, the emergency PowPak will return to the previous light level in most cases within 3 minutes, but guaranteed within 10 minutes of normal power being restored. It will again accept local button control, input from Pico wireless controls, and occupancy/daylight sensors.

Without a Vive hub:

- **Normal mode:** The RMJS-8T-DV-B-EM can dim loads as normal and respond to local button presses, Pico wireless controls, and occupancy/daylight sensors.
- If the emergency PowPak loses power for greater than 250 mS, it will automatically go into emergency mode (full output, relay closed) for 90 minutes, when emergency power is restored to the PowPak. All local buttons, Pico wireless controls and occupancy/daylight sensors will not respond for 90 minutes.
- When normal power is restored, the emergency PowPak will remain in emergency mode for 90 minutes (full output, relay closed). It will then return to the previous light level and accept local button control, inputs from Pico wireless controls, and occupancy/daylight sensors.

Default Operation

- Associated wireless input devices control all connected fixtures together
- Occupancy Sensors:
 - Occupied: 100%; Unoccupied: 0% (OFF)
- Pico Remote Controls:
 - On: 100%; Favorite Level: 50%; Off: 0% (OFF)
- Daylight Sensor: Decreases electric light in response to additional available daylight

Key Design Features

- LED status indicator shows load status and provides programming feedback
- Configurable high-end and low-end trim
- Power failure memory: If power is interrupted, connected loads will return to the previous level prior to interruption
- 0–10 V_{DC} control mis-wire protection up to 30 V_{DC}

Warranty

- 1 year limited warranty. The customer can register the product to increase the warranty period from 1 year to 5 years. Please visit www.lutron.com/TechnicalDocumentLibrary/369-119_Wallbox_Warranty.pdf for warranty details.

Job Name:	Model Numbers:
Job Number:	

Advanced Configurations

Pico Remote Controls

- Up to 10 Pico remote controls
- Favorite levels can be set for each Pico remote control

Radio Powr Savr Daylight Sensor

- The Radio Powr Savr daylight sensor will affect all connected ballast and LED drivers equally
- For multiple rows of daylighting, a separate PowPak Dimming Module with 0–10 V_{DC} must be used for each daylighting row

Minimum Light Level Setting (optional)

- Certain applications, such as hallways, may require that the lights never turn off. For these areas, select the minimum light level option and the load will lower to programmed low-end level. Default operation lowers to OFF.

High- and Low-End Trim

- High-end and low-end trim affect all connected fixtures equally, and can be configured from the PowPak Dimming Module.
- Adjustable low-end trim (0%–45%). Trimmable low-end can ensure a stable light level. Some fixtures will flicker or drop out if trimmed too low.
- The maximum light output of connected fixtures can be decreased down to 55% for energy savings in over-lit spaces.

Note: The perceived light output of low-end trim may vary between fixture manufacturers and model numbers. For best results, do not mix different ballasts or drivers on the same 0–10 V_{DC} circuit.

Radio Powr Savr Occupancy Sensors

- Radio Powr Savr occupancy and vacancy sensors control all connected ballasts or drivers.
- Pico remote controls can be used to adjust the Occupied levels of fixtures that they control from 1% to 100% (of output signal) or can make them unaffected by Occupancy events.
- Vacancy events (area becomes unoccupied) turn all ballasts and driver models off or to minimum light level.

<p>Job Name:</p> <p>Job Number:</p>	<p>Model Numbers:</p>
--	------------------------------

System Diagram

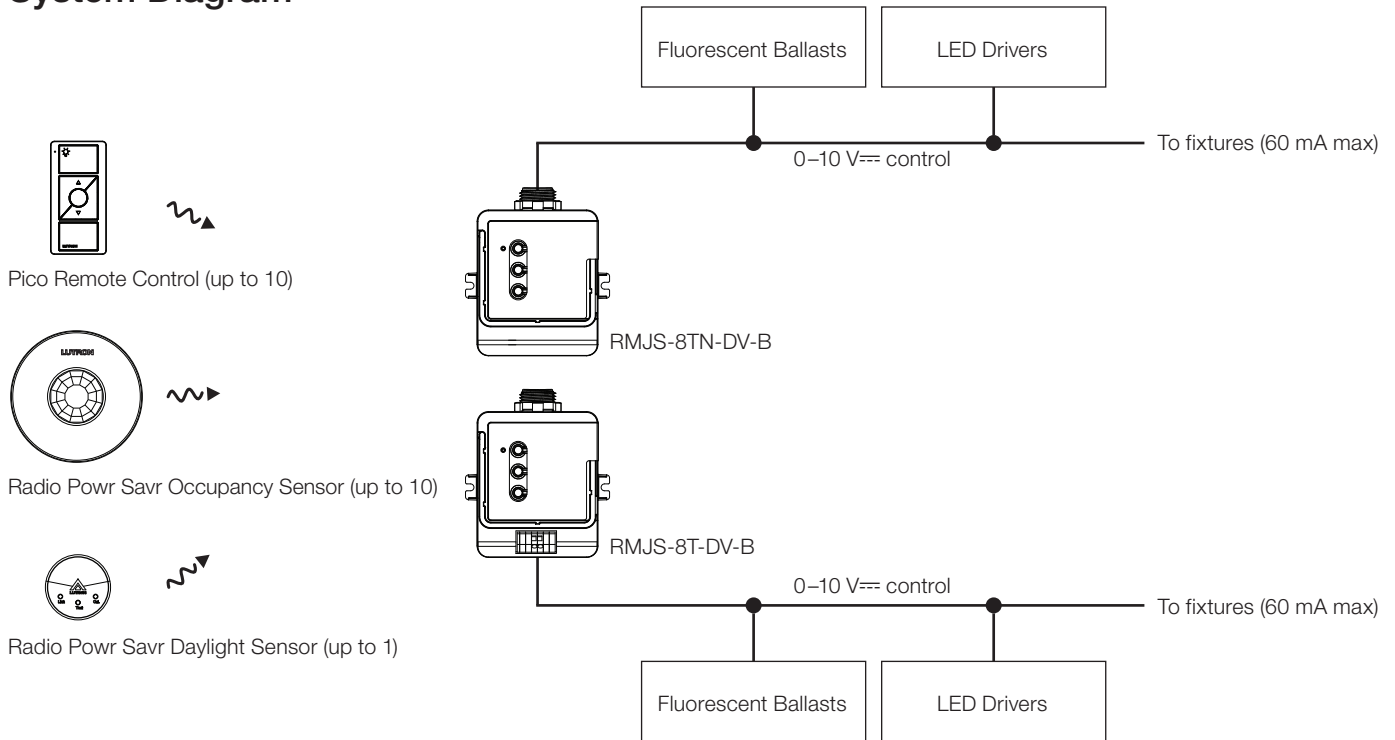

Wiring Schematic

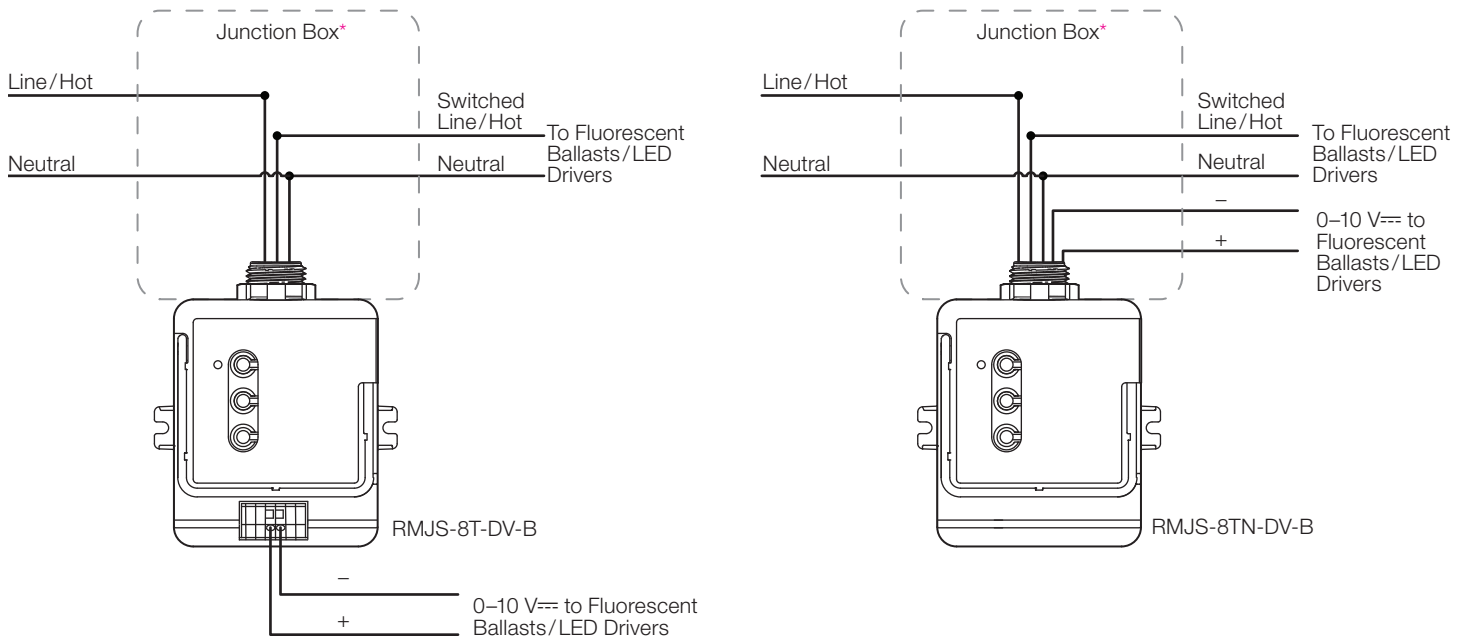

* **NOTE:** The control module mounts to the exterior of a U.S.-style junction box.

Job Name:	Model Numbers:
Job Number:	

System Wiring Diagram (Vive Hub with Emergency PowPak)

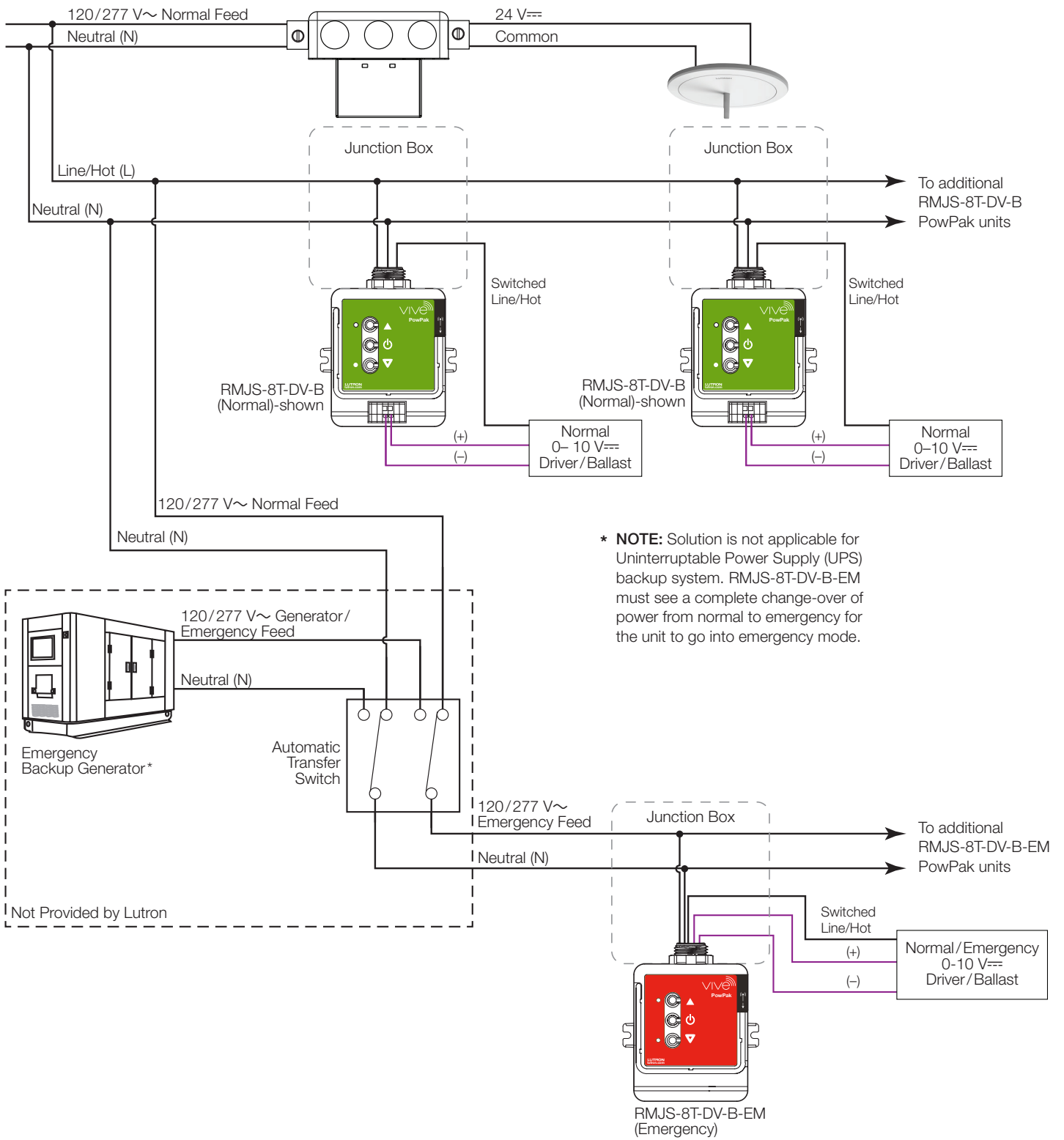

Job Name:	Model Numbers:
Job Number:	

Dimensions

Dimensions are shown as: in (mm)

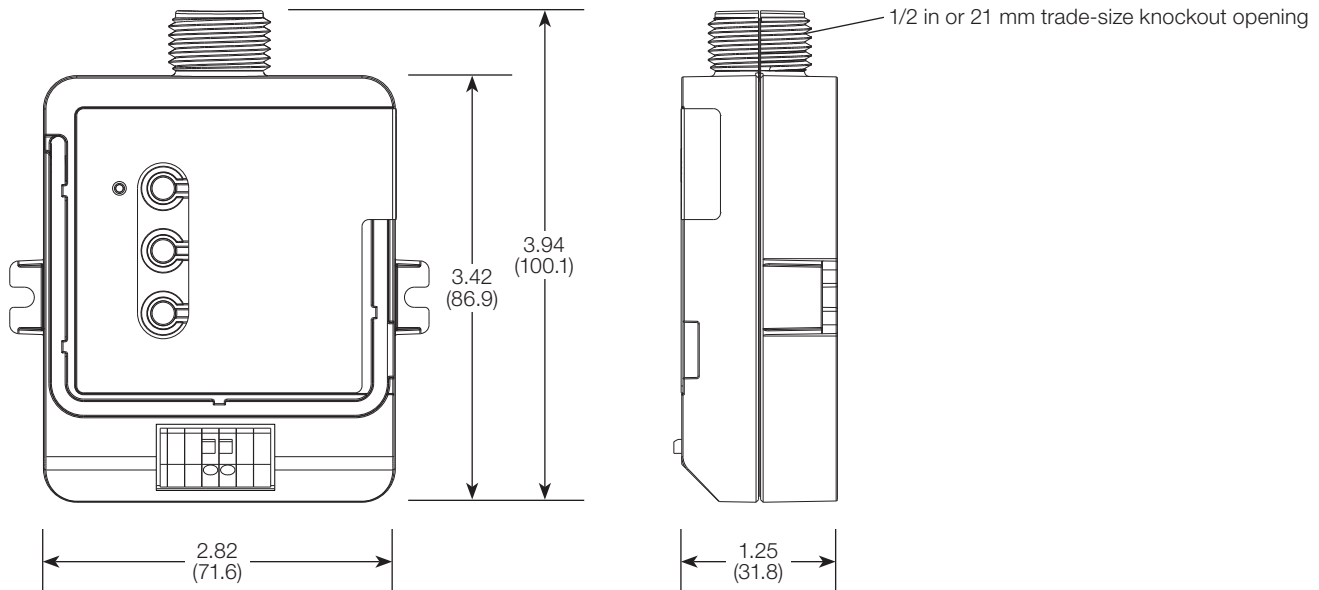

Range Diagram

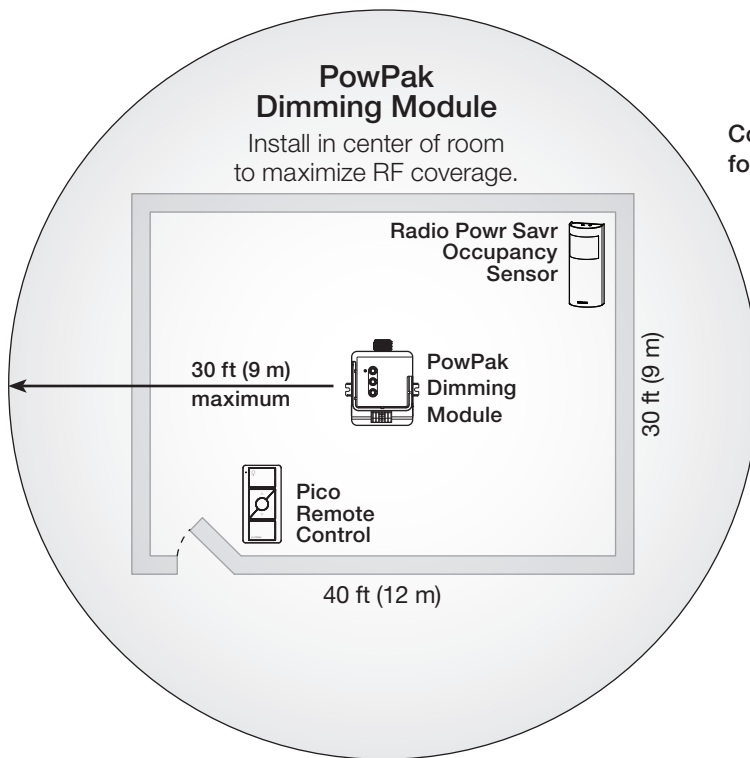

Contact Lutron first for applications using foil-backed or metallic ceiling tiles.

NOTE: Wireless sensors and controls must be located within 60 ft (18 m) line of sight, or 30 ft (9 m), through walls, of the associated control module. The 60 ft (18 m) range is not reduced by a ceiling tile obstruction.

Lutron, Lutron, PowPak, Clear Connect, Pico, and Vive are trademarks of Lutron Electronics Co., Inc. registered in the U.S. and other countries

Radio Powr Savr is a trademark of Lutron Electronics Co., Inc.

NEC is a registered trademark of National Fire Protection Association, Quincy, Massachusetts.

UL is a trademark of UL LLC.

Job Name:	Model Numbers:
Job Number:	