

► Model 52

Resonating Horn

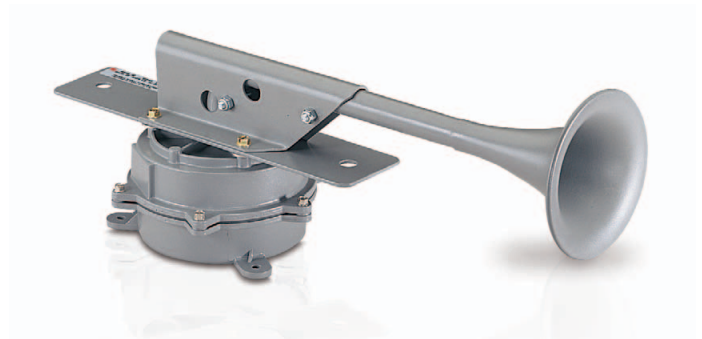

Model 52 resonating horn is ideal for penetrating high ambient noise levels. Being electrically-activated, the Model 52 does not require an expensive air compressor for operation. It is able to withstand the shocks, vibrations, dust and atmospheric conditions encountered in off-road use.

Rubber gaskets and a power connector make the Model 52 completely watertight. The projector and internal parts are made to resist corrosion; the exterior is sealed with gray enamel paint and the housing is die-cast aluminum. The Model 52 has a duty cycle of five minutes on and five minutes off.

Used by many major manufacturers of construction equipment, Model 52 resonating horns suit the warning needs of any off-road vehicle working in a high noise environment.

FEATURES

- Available in 24VDC
- Withstands extreme outdoor conditions
- Produces 114 dBa @ 10' (124 dBa @ 1m) with 1,000 ft. range
- Shock and vibration resistant
- Surface mount with flanges
- Type 4X enclosure

MODEL	VOLTAGE	OPERATING CURRENT	DECIBELS	
			10'	1M
52-024-1	24VDC	4.0 amps	114	124

Resonating Horn (52)

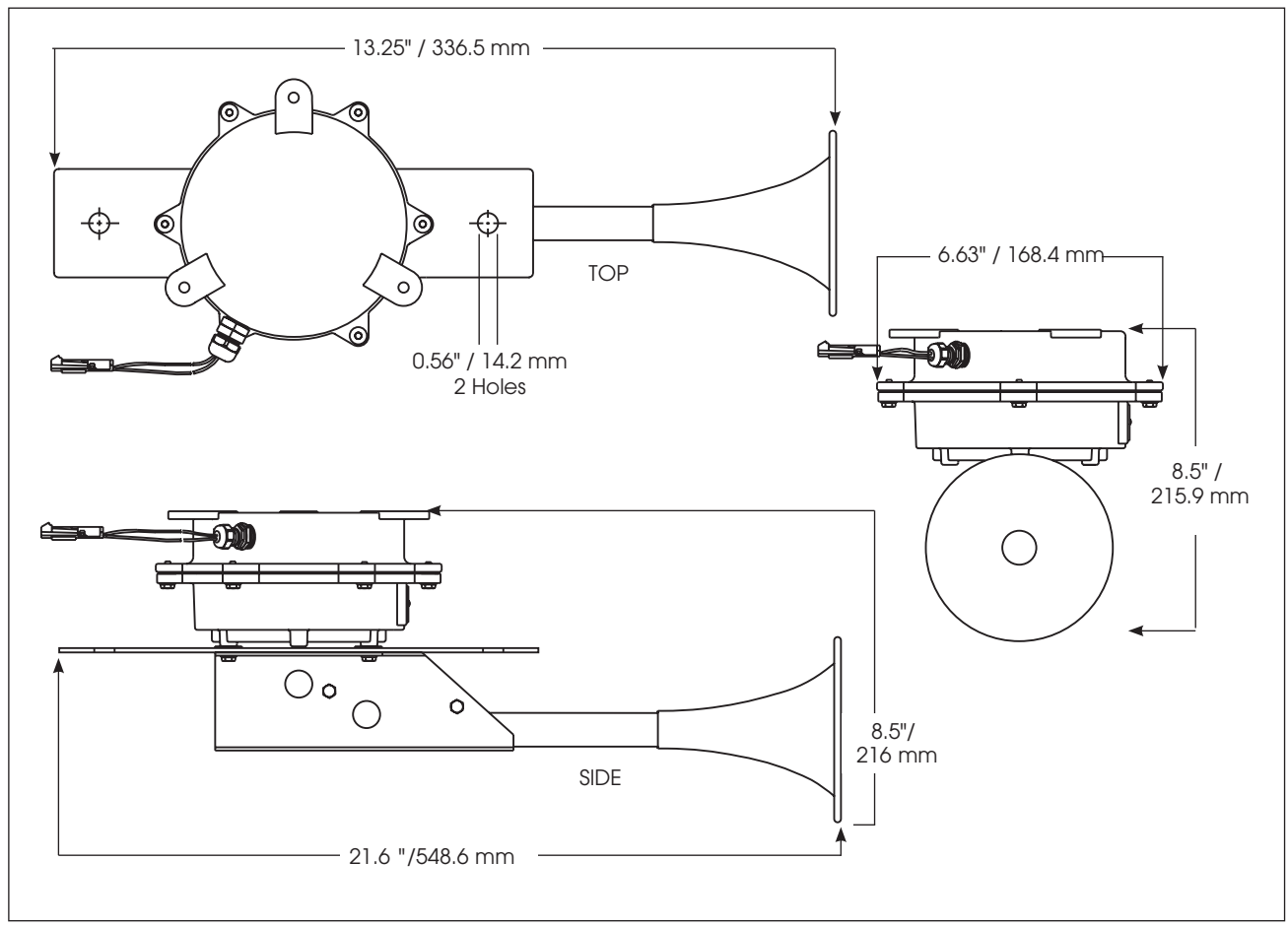

SPECIFICATIONS

Operating Temperature:	-40°F to 185°F	-40°C to 85°C
Net Weight:	9.0 lbs	4.08 kg
Shipping Weight:	10.0 lbs	4.54 kg
Height:	8.5"	216 mm
Width:	6.63"	168.4 mm
Depth:	21.6"	548.6 mm

HOW TO ORDER

Specify Model:
52-024-1 – Resonating Horn, 24VDC