



► Model 151XST

Hazardous Location Warning Light A B C G R

Model 151XST hazardous location strobe light provides 80 high-intensity flashes per minute. This hazardous location warning light has an aluminum base, coated for corrosion-resistance, that can be ordered for mounting on a 3/4-inch NPT pipe or a surface. The Dome Guard (included) fits over the glass dome to protect it against accidental collision with moving equipment, such as forklifts.

Federal Signal's rugged 151XST strobe warning light is specifically designed for hazardous locations or corrosive environments where a very bright visual signal is required. This warning light can be used for plant evacuation or other communication needs.

FEATURES

- Available in 12-24VDC, 120VAC and 240VAC
- Five dome colors: Amber, Blue, Clear, Green and Red
- 10,000-hour high-intensity strobe
- Available in 3/4-inch NPT pipe mount or surface mount
- Dome guard included
- Indoor/outdoor use
- Type 4X, IP66, IP69K enclosure
- Marine rated
- UL and cUL Listed for Class I, Division 2, Groups A, B, C and D; Class II, Division 1, Groups E, F, and G; and Class III

MODEL	VOLTAGE	OPERATING CURRENT	FLASH RATE/ MINUTE	LIGHT OUTPUT PEAK ¹	ECP ²
151XST-*012-024**	12-24VDC	1.3-0.60 amps	80	520,000 cd	165 cd
151XST-*120**	120VAC 50/60Hz	0.35 amps	80	520,000 cd	165 cd
151XST-*240**	240VAC 50/60Hz	0.18 amps	80	520,000 cd	165 cd

* Include (S) for Surface Mount Option (Example part number: 151XST-S120R for surface mount option, 151XST-120R for pipe mount)

** Indicates color: (A) Amber, (B) Blue, (C) Clear, (G) Green or (R) Red

¹ Peak candela is the maximum light intensity generated by a flashing light during its light pulse

² ECP (Effective Candela) is the intensity that would appear to an observer if the light were burning steadily

HAZARDOUS LOCATION RATING: 151XST

T-CODE AT MAXIMUM AMBIENT TEMPERATURE, °C

Hazardous Location	40°C
Class I, Division 2, Groups A, B, C, D	T2A
Class II, Division 1, Groups E, F, G	T5
Class III	T5

Hazardous Location Strobe Light (151XST)

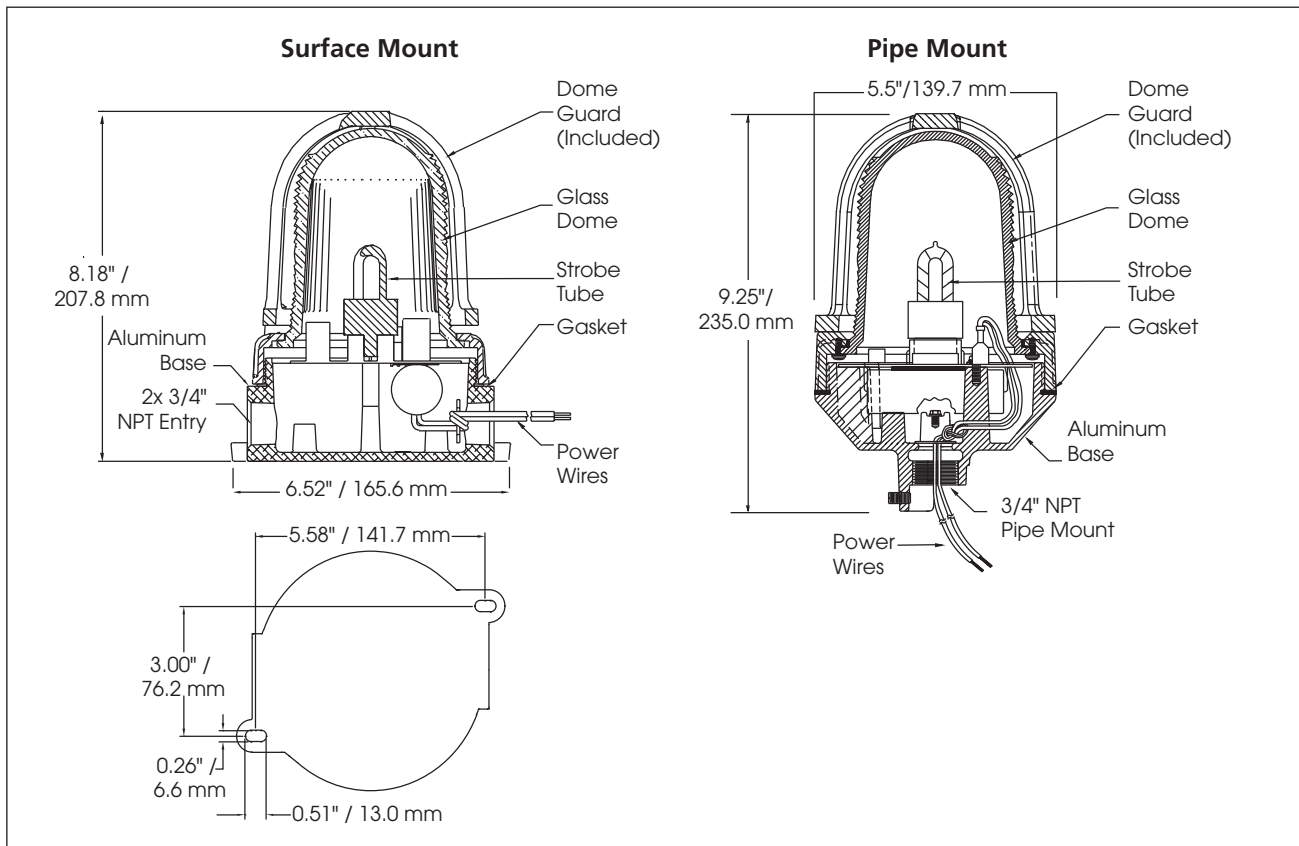

SPECIFICATIONS

Lamp Life:	10,000 Hours	
Light Source:	Strobe tube	
Operating Temperature:	-67°F to 150°F	-55°C to 66°C
Net Weight:	3.8 lbs	1.7 kg
Shipping Weight:	4.5 lbs	2.0 kg
Pipe Mount		
Height:	9.25"	235.0 mm
Diameter:	5.5"	139.7 mm
Surface Mount		
Height:	8.18"	207.8 mm
Diameter:	6.52"	165.6 mm

REPLACEMENT PARTS

Description	Part Number
Series C Dome and Ring Assembly	
Dome & Ring Assembly, Amber ¹	K8449078C-01
Dome & Ring Assembly, Blue ¹	K8449078C-06
Dome & Ring Assembly, Clear ¹	K8449078C-04
Dome & Ring Assembly, Green ¹	K8449078C-07
Dome & Ring Assembly, Red ¹	K8449078C
PC Assembly, 12-24VDC	K2001173C
PC Assembly, 120VAC	K2001071B
PC Assembly, 240VAC	K2001071B-01
Strobe Tube	K149122B
Dome Guard	K8449090B

¹ Includes dome gasket

HOW TO ORDER

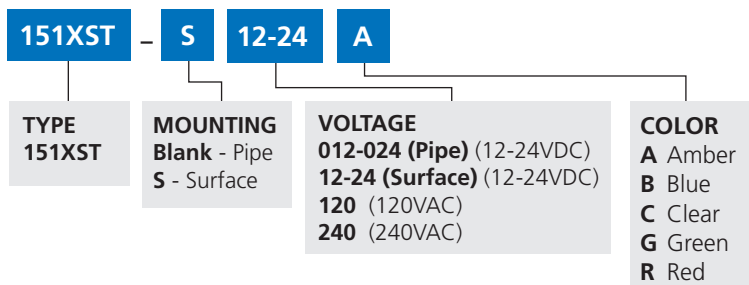

OPTIONAL ACCESSORIES

Description	Part Number
Hazardous Location Mounting Bracket	LHWB

Mounting Brackets shown on pages 136-137