

# SERVICE BULLETIN SB - 268

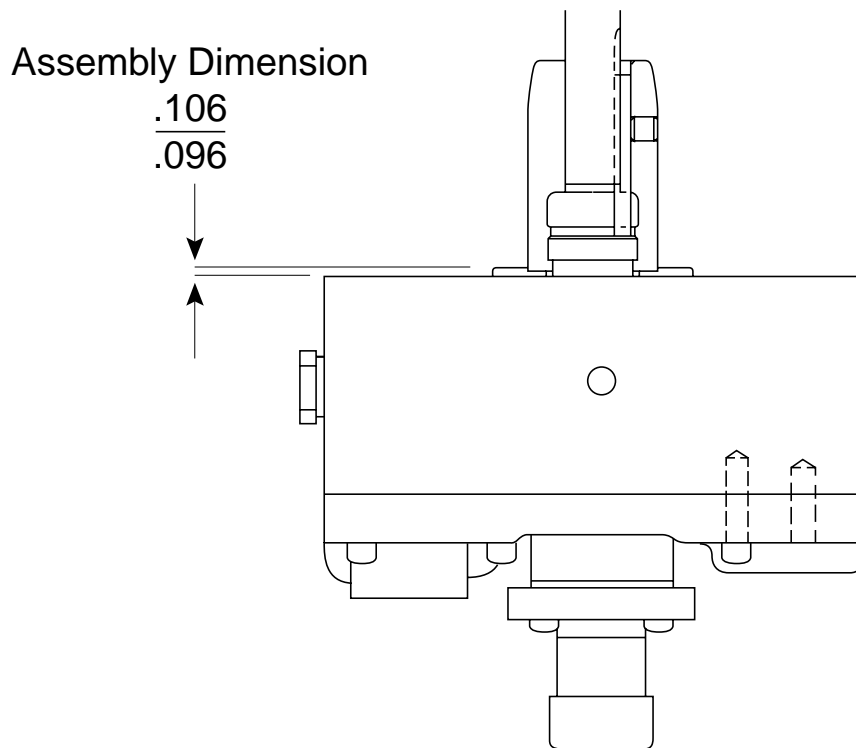

## PRODUCT ADVISORY 960 and 1700 Series Hydraulic Power Pumps

It has come to our attention that the Instruction Manuals for the 960 and 1700 Series Hydraulic Power Pumps do not show the dimension that the top bearing (905 1473.4) should be in relation to the top surface of the pump block.



It should measure between .096 and .106 from the top of the block to the top of the bearing to obtain the proper spacing required for the location of the motor mounting plate.

If you have any questions concerning this matter, please contact the Greenlee Textron Field Service Department at 1-800-435-0786.

Dennis DeVlieger  
Field Service Manager

# **GREENLEE **TEXTRON****

**Greenlee Textron Inc. / Subsidiary of Textron Inc.**

4455 Boeing Drive, Rockford, IL 61109-2988 USA

General Offices: 815/397-7070

Customer Center and Field Service: 800/435-0786

Fax (24 Hour) Customer Center: 800/451-2632 • 815/397-1865

Canada Fax (24 Hour) Customer Center: 800/524-2853

Printed in U.S.A.