

Ram and Hand Pump Hydraulic Driver Kits (Inch and Metric)



- Fast, easy and simple to operate.
- Compact design for field use on construction sites and maintenance jobs.
- Punches 10 times faster than wrench method.
- Will also drive 751 Cable Cutter head.
- Can be used with most standard round Slug-Buster® and Slug-Splitter SC™ punches (not 1/2", 9/16", 5/8").
- Can be used with non-round punches (adapter may be required).
- 3-foot hose
- Powerful 11-ton hydraulic ram.

CAT. NO.	UPC NO.	DESCRIPTION	WEIGHT	
			LBS.	kg.
7646	15906	Driver with Hand Pump, Draw Studs, Spacer and Plastic Case	20	9.1
7306	15909	Driver, Hand Pump, Standard Punches, Dies and Draw Studs for 1/2" through 2" Conduit, Plastic Case	24	10.9
7306SB	34360	Driver, Hand Pump, Slug-Buster® Punches, Dies and Draw Studs for 1/2" through 2" Conduit, Adapter, Spacers, Kwik Stepper® Step Bit and Plastic Case	24	10.9
7310	15910	Driver, Hand Pump, Standard Punches, Dies and Draw Studs and Spacers for 1/2" through 4" Conduit, Steel Case	54	24.5
7310SB	34361	Driver, Hand Pump, Slug-Buster® Punches, Dies and Draw Studs for 1/2" through 2" and 2-1/2" through 4" Standard Conduit Size Punches, Dies and Draw Studs, Adapter, Spacers, Kwik Stepper® Step Bit and Steel Case	54	24.5
7646Pg	27433	Metric – Driver, Hand Pump, Standard Pg Punches, Dies and Draw Studs and Spacers for 15.2 mm through 60.0 mm, Plastic Case	24	10.9
7646PgSB	32799	Metric – Driver, Slug-Buster® Pg Punches, Dies and Draw Studs for 15.2 mm through 60.0 mm, Adapter, Spacers, Kwik Stepper® Step Bit and Plastic Case	24	10.9
7304	02815	Standard Punch and Die Kit (no draw studs) for 2-1/2" through 4" Conduit, Plastic Case	21	9.5
38456	38456	Driver, Hand Pump, Standard Punches, Dies and Draw Studs and Spacers for 1/2" through 3" and 4" Conduit, Steel Case	48.4	22
38520	38520	Driver, Hand Pump, Slug-Buster® Punches and Draw Studs for 1/2" through 3" and 4" Conduit, Adapter, Spacers, Kwik Stepper® Step Bit and Steel Case	48	21.8

STEEL CAPACITIES FOR CONDUIT SIZES

REQUIRED DRAW STUD AND ACCESSORIES	STANDARD & SLUG-BUSTER® PUNCHES						STANDARD				SLUG-SPLITTER SC™					
	1/2"	3/4"	1"	1-1/4"	1-1/2"	2"	2-1/2"	3"	3-1/2"	4"	1/2"	3/4"	1"	1-1/4"	1-1/2"	2"
3/4" Stud (03294), 3/8" Stud (30043) & Spacers	///															
3/4" Stud (03294), Long Spacer		///	///	///												
3/4" Stud (03294), Short Spacer					///											
3/4" Stud (03294)							///									
3/4" Stud (03294), & Sleeve (03170)								///								
7/16" Stud (29451)											///					
3/4" Stud (29452)												///	///	///	///	///

/// 10 GA. MILD STEEL ▨ 10 GA. STAINLESS STEEL

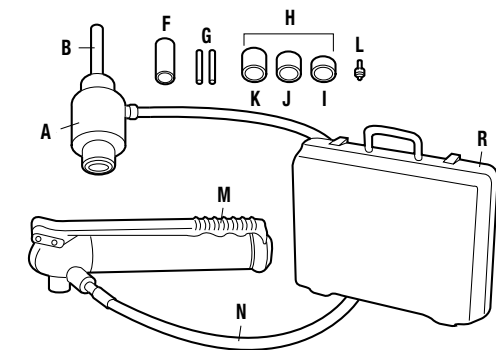

(R) = REPLACEMENT PART (A) = ACCESSORY

RAM AND HAND PUMP HYDRAULIC DRIVER PARTS IDENTIFICATION

KEY	CAT./UPC NO.	DESCRIPTION
A	746 / 17091	(R) Ram (includes Item B)
B	2113AA / 03294	(R) Draw Stud-3/4" x 5-3/8"
F	1557AA / 03170	(R) Punch Sleeve
G	1614SS / 30043	(R) Draw Stud-3/8" x 2-13/16"
H	15908	(R) Spacer Group (includes Items I, J and K)
I	1924AA / 03248	(R) Spacer-Short
J	1925AA / 03249	(R) Spacer-Medium
K	1926AA / 06904	(R) Spacer-Long
L	34410	(R) Kwik Stepper® Step Bit 1/2"
M	767 / 13284	(R) Hydraulic Hand Pump
N	06302 / 06302	(R) High Pressure Hose-1/4" x 3'
R	30206	(R) Plastic Case