

JBM-100
Power connection/splice/tee

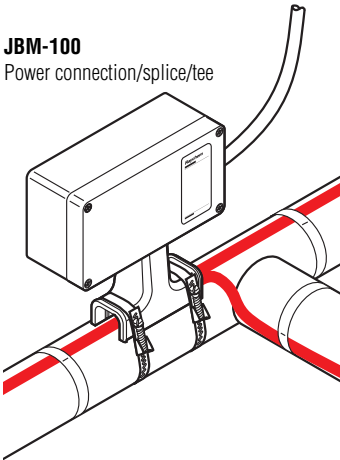

E-100-L
Lighted end seal

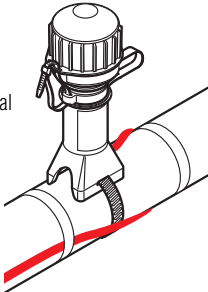

E-100
End seal

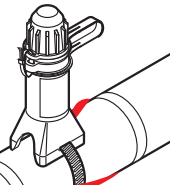

T-100
Tee or splice connection

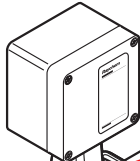

JBS-100
Power connection

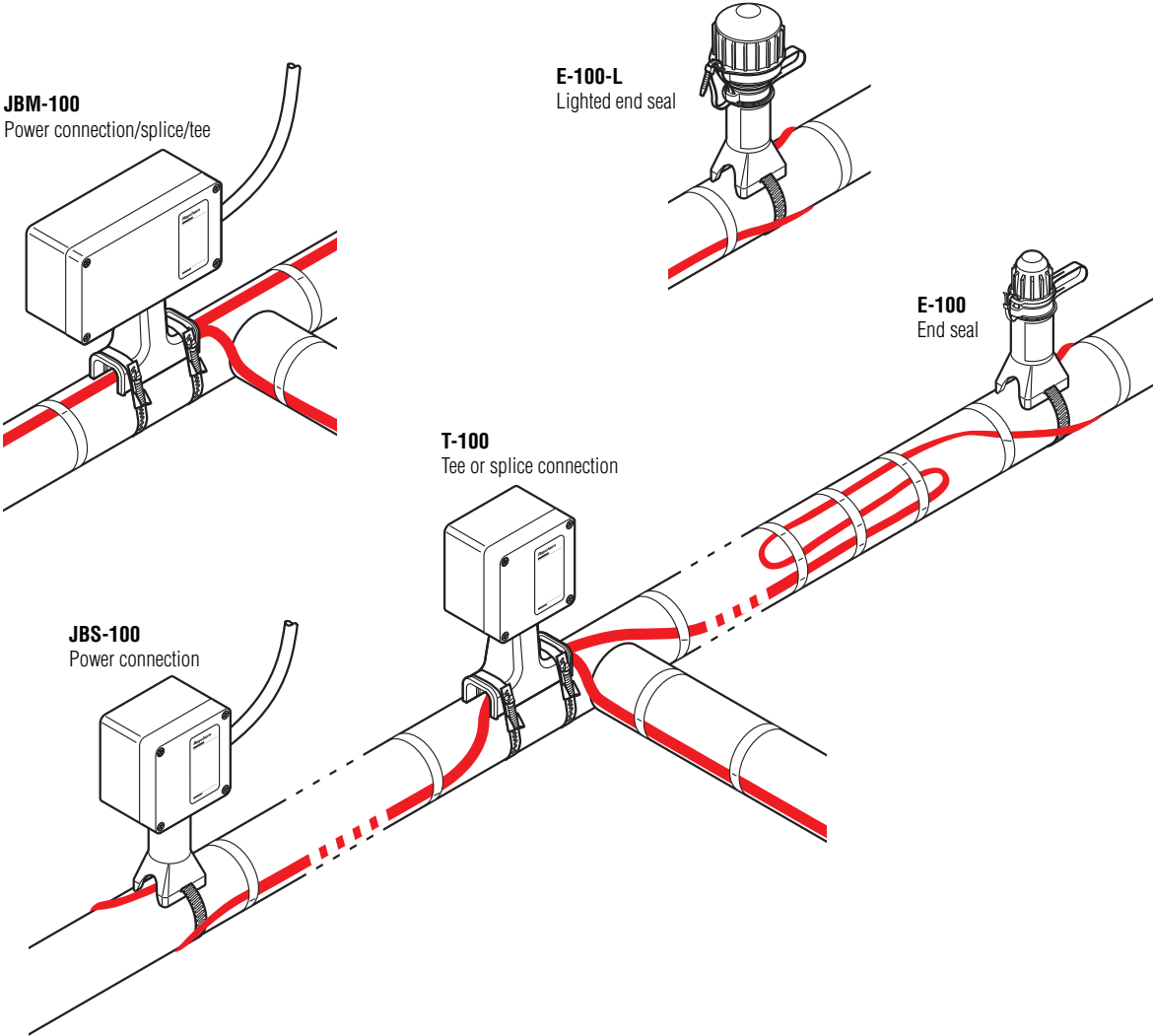
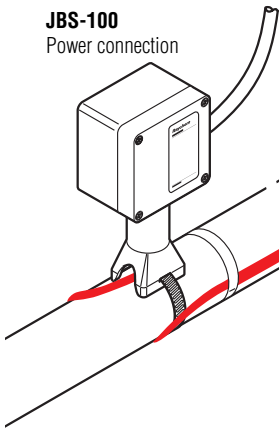

Introduction

This guide is designed for the selection of connection components, controls, and accessories for use with Raychem BTV, QTVR, XTV, and KTV self-regulating heating cables. Before using this guide, select the appropriate heating cable using the Heat-Tracing Design Guide (H51149) or TraceCalc design software.

This guide does not cover component selection for LBTV, VL, and AutoSense M-wire heating cables. Contact your local Raychem representative for assistance in selecting components for these products.

System approvals, warranty, and performance require the use of Raychem-specified components. Be sure to use the correct Raychem components for your application and do not substitute parts.

Products in this guide are suitable for use in both ordinary and Division 2 hazardous locations. For Division 1 hazardous locations, a separate selection guide is available (H56075).

Raychem offers a wide range of other heating products for the industrial market, including mineral-insulated cables, tank heating pads, long-line heating cables, and plantwide monitoring and control systems. Contact your local Raychem representative for additional information.

Raychem requires ground-fault protection for all Raychem heating cables. A list of ground-fault protection devices is included in the selection guide.

Contents

System Overview	1
Pipe-Tracing Components	2
Tank-Tracing Components	3
Controls—Ordinary Areas	4
Controls—Hazardous Areas	5
Ground-Fault Equipment Protection Devices	6
Accessories	7
Heat-Tracing System Worksheet	10
Data Sheets	11

System Overview

Typical Heat-Tracing System

The typical heat-tracing system consists of the components shown in the schematic below. All of the components work together to provide a safe and reliable heat-tracing system that is easy to install and maintain.

The self-regulating heating cable is cut to length at the job site and attached to the piping or tank surface with glass tape. A power connection kit is used to connect power to one end of the heating cable. An end seal kit is used to seal the other end of the heating cable. Splice and tee kits are used as necessary to connect two or three heating cables together. The heating cable may be controlled automatically by electromechanical or electronic thermostats, which sense either ambient or pipe temperature.

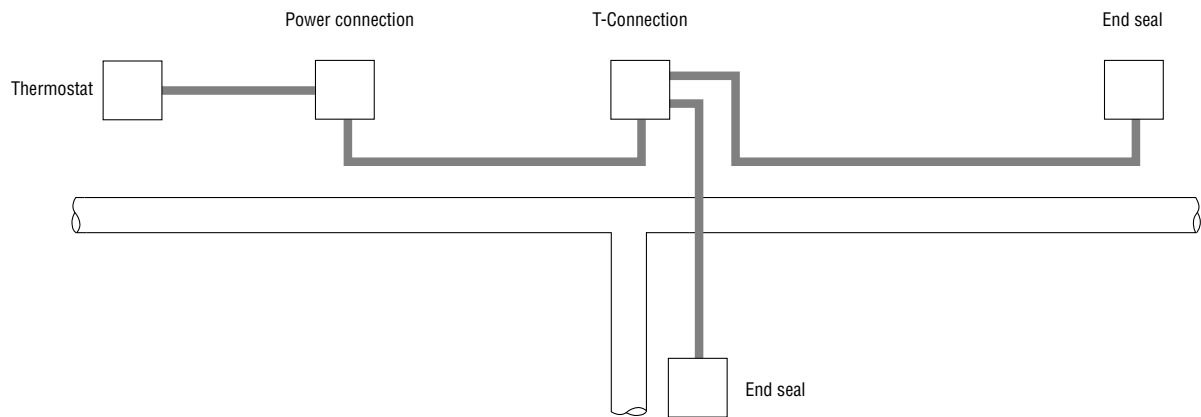

Additional Information

Design literature, data sheets, and installation instructions supplement the information in this selection guide. These documents are available from your local Raychem representative, from Raychem's Fax-On-Demand system (800-329-4494), and from Raychem's Web site (www.raychem.com).

Pipe-Tracing Components

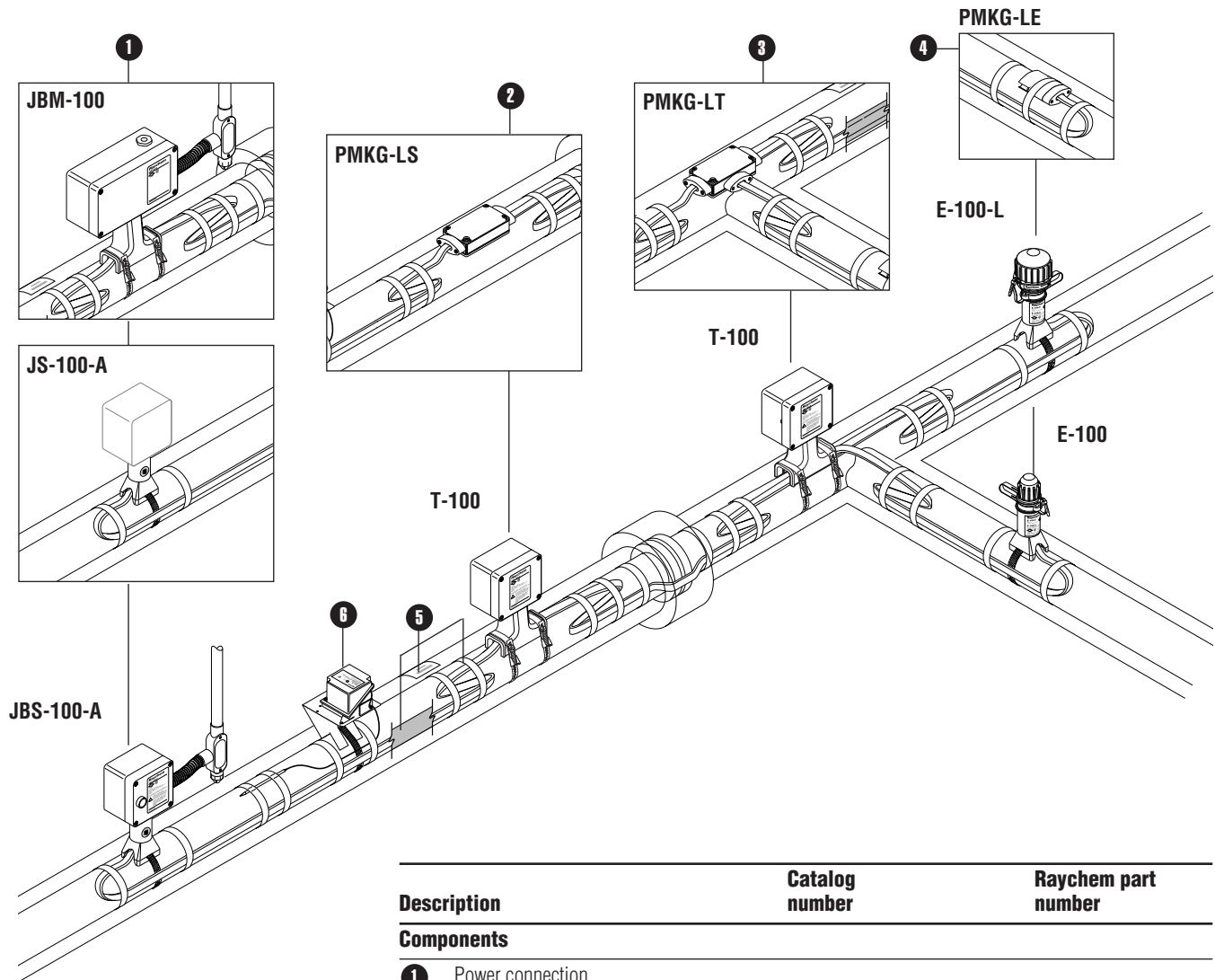

Description	Catalog number	Raychem part number
Components		
1 Power connection		
Single heating cable	JBS-100-A	085947-000
Single heating cable (user-supplied junction box)	JS-100-A	166639-000
Multiple heating cables (1, 2, or 3)	JBM-100-A	179955-000
2 Splice connection		
Above insulation	T-100	447379-000
Below insulation	PMKG-LS	045551-000
3 Tee connection		
Above insulation	T-100	447379-000
Below insulation	PMKG-LT	848907-000
4 End seal		
Above insulation	E-100-A	046567-000
Above insulation, with light	E-100-L1-A (100–120 V) E-100-L2-A (200–277 V)	583377-000 478767-000
Below insulation	PMKG-LE	982199-000
Accessories		
5 Attachment tape and labels (see Accessories, pages 8 and 9)		
Controls		
6 Thermostat (see Controls, pages 4 and 5)		

Tank-Tracing Components

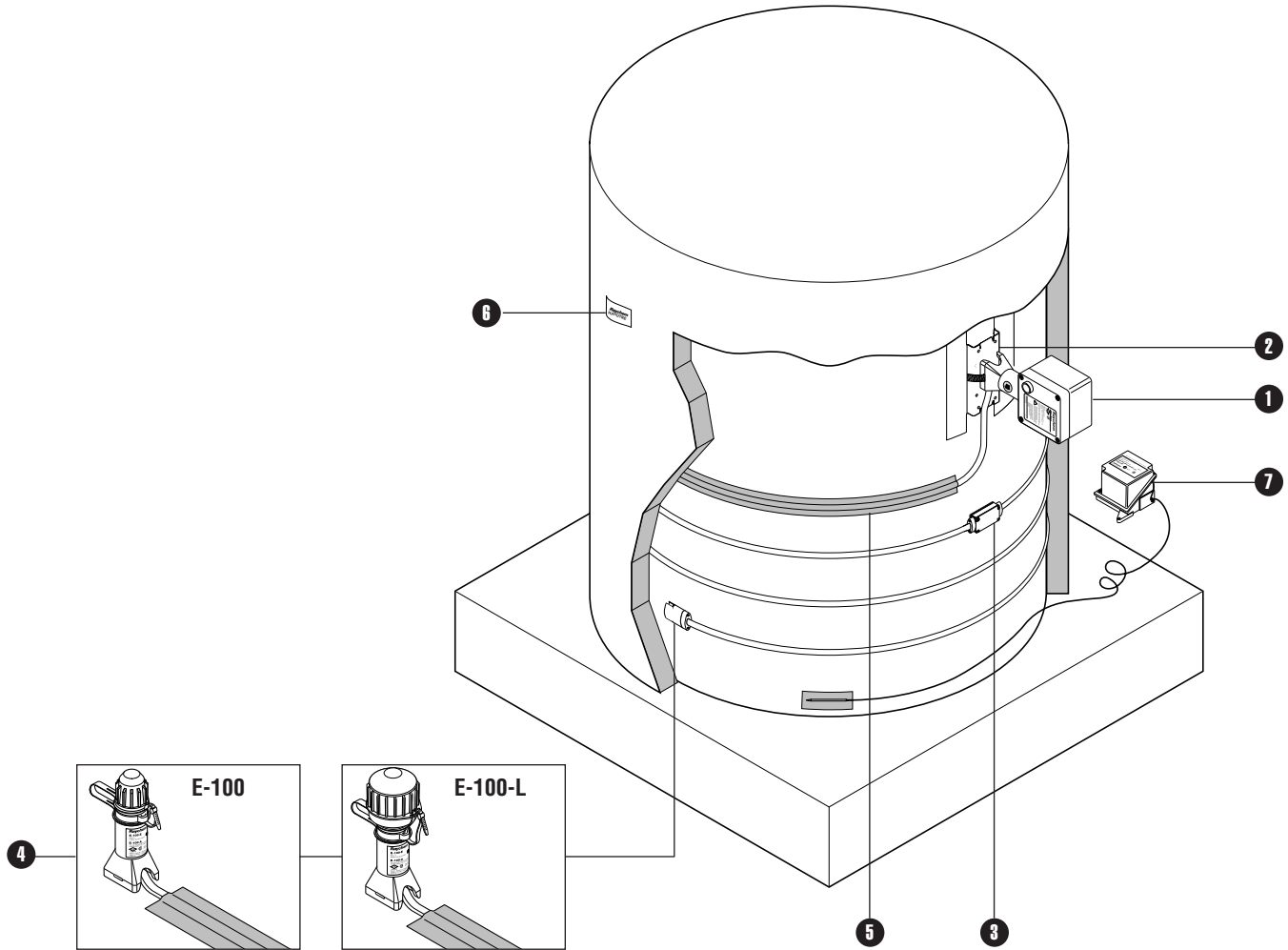

Description	Catalog number	Raychem part number
Components		
① Power connection	JBS-100-A	085947-000
② Support bracket	SB-100-T	279613-000
③ Splice connection	PMKG-LS	045551-000
④ End seal		
Below insulation	PMKG-LE	982199-000
Above insulation	E-100-A	046567-000
Above insulation, with light	E-100-L1-A, 100–120 V E-100-L2-A, 200–277 V	583377-000 478767-000
Accessories		
⑤ Aluminum tape	AT-180	158139-000
⑥ Labels (see Accessories, page 9)		
Controls		
⑦ Thermostat (see Controls, pages 4 and 5)		

Note: RHS tank heating pads are also available for tank-heating applications on metal and plastic tanks. Contact your Raychem representative for further information.

Ambient-sensing thermostats

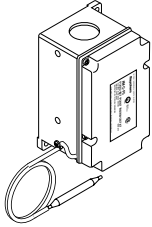
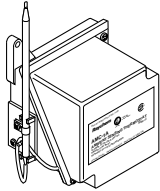
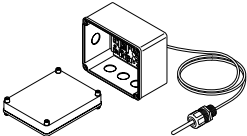
	Catalog No.	Part No.	Description
	AMC-F5	031661-000	Fixed 40°F (4.4°C) set point for freeze protection applications. Single-pole, 22 A. NEMA 4X.
	AMC-1A	573977-000	Set point range: 15°F to 140°F (–9°C to 60°C). Single-pole, 22 A. NEMA 4X.
	RAYSTAT-ECO-01	178917-000	Electronic, energy-saving freeze protection controller. ON below 40°F (4.4°C). Single-pole control relay rated 3 A. External contactor required. NEMA 4X.

Line-sensing thermostats

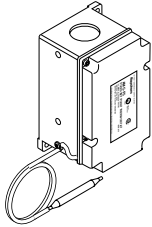
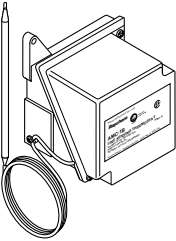
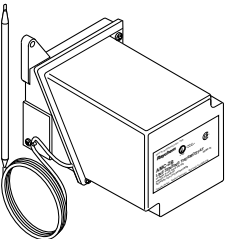
	Catalog No.	Part No.	Description
	AMC-F5	031661-000	Fixed 40°F (4.4°C) set point for freeze protection applications. Single-pole, 22 A. NEMA 4X.
	AMC-1B	943533-000	Set point range: 25°F to 325°F (–4°C to 163°C). Single-pole, 22 A. NEMA 4X.
	AMC-2B	042817-000	Set point range: 25°F to 325°F (–4°C to 163°C). Double-pole, 22 A. NEMA 4X.

Note:

All controls listed on this page (except MoniTrace 1000 and RAYSTAT-EX-03-A) are approved for use in the following areas:

- Class I, Div. 1 and 2, Groups B, C, D
- Class II, Div. 1 and 2, Groups E, F, G
- Class III

Ambient-sensing thermostats

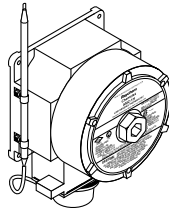

Catalog No.

AMC-1H

Part No.

889067-000

Description

Set point range:
15°F to 140°F (–9°C to 60°C).
Single-pole, 22 A. NEMA 4, 7, 9.

Line-sensing thermostats

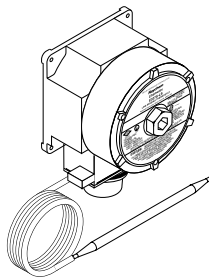

Catalog No.

E507S-LS

Part No.

625725-000

Description

Set point range:
25°F to 325°F (–4°C to 163°C).
Single-pole, 22 A. NEMA 4, 7, 9.

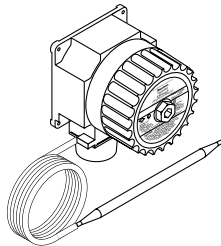

Catalog No.

E507S-2LS

Part No.

257301-000

Description

Set point range:
25°F to 325°F (–4°C to 163°C).
Double-pole, 22 A. NEMA 4, 7, 9.

Note:

MoniTrace 1000 and RAYSTAT-EX-03-A are approved for use in the following areas:

- Class I, Div. 2, Groups A, B, C, D
- Class II, Div. 1 and 2, Groups E, F, G
- Class III

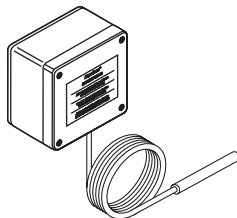

Catalog No.

RAYSTAT-EX-03-A

Part No.

453609-000

Description

Electronic line-sensing thermostat.
Set point range:
32°F to 930°F (0°C to 499°C).
Double-pole, 16 A. NEMA 4X.
[Available January 1999]

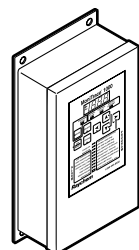

Catalog No.

MONITRACE 1000

Part No.

716381-000

Single-circuit electronic controller.
Range: –40°F to 999°F (–40°C to 537°C). Double-pole solid-state switch rated 30 A, 277 V. NEMA 4X. Integral ground-fault equipment protection. Temperature and current display and alarms. Diagnostic tests.

Ground-Fault Equipment Protection Devices

All Raychem heating cables must be installed with electrical protection in accordance with local codes and practices.

Ground-Fault Circuit Breaker Selection Table

The following breakers are available from your local Raychem representative:

Bolt-on Style					
Manufacturer	Square D		Cutler Hammer (Westinghouse)		Raychem TraceGuard*
Voltage (amps)	120	208/240**	120	208/240**	277
15	QOB115EPD	QOB215EPD	QBGFEP1015	QBGFEP2015	EHB14015EPD
20	QOB120EPD	QOB220EPD	QBGFEP1020	QBGFEP2020	EHB14020EPD
30	QOB130EPD	QOB230EPD	QBGFEP1030	QBGFEP2030	EHB14030EPD
40	—	—	—	QBGFEP2040	EHB14040EPD
50	—	—	—	QBGFEP2050	EHB14050EPD
Panelboard	NQOD	NQOD	POW-R-LINE 1	POW-R-LINE 1	NEHB
Plug-on Style					
Manufacturer	Square D		Cutler Hammer (Westinghouse)		Raychem TraceGuard*
Voltage (amps)	120	208/240**	120	208/240**	277
15	QO115EPD	QO215EPD	QPGFEP1015	QPGFEP2015	—
20	QO120EPD	QO220EPD	QPGFEP1020	QPGFEP2020	—
30	QO130EPD	QO230EPD	QPGFEP1030	QPGFEP2030	—
40	—	—	—	QPGFEP2040	—
50	—	—	—	QPGFEP2050	—
Panelboard	QO Load Center	QO Load Center	POW-R-LINE 1	POW-R-LINE 1	—
Padlock attachment***	QO1PA	GF12PA	QLPB123PL	QLPB123PL	GFPOHPA-EH

* Raychem's TraceGuard 277 circuit breaker is manufactured by Square D.

** Two-pole ground-fault breakers require 120 volts to power the internal electronics. 240-volt delta systems without a 120-volt neutral reference will require an additional transformer to provide the reference.

*** Padlocks are required to comply with NEC section 427-55(a) if the circuit breaker is utilized as a disconnecting means.

Cold-applied core sealer

Catalog No.	Part No.	Description
CS-100-A	232949-000	Heating Cable Connection Insulator

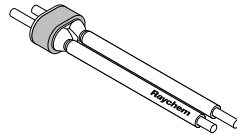

Replacement cold-applied core sealer for Raychem BTV, QTVR, XTV, and KTV heating cables.

Single-entry transition kit

Catalog No.	Part No.	Description
JS-100-A	166639-000	Junction Box Stand

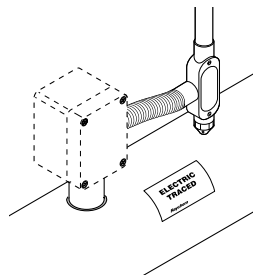

Junction box stand for use with Raychem BTV, QTVR, XTV, and KTV self-regulating heating cables. A separate customer-supplied NEMA 4X junction box is required.

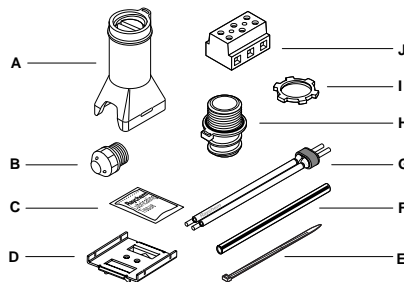

Kit Contents

Item	Description
A	Stand assembly
B	Conduit drain
C	Cleaning tissue
D	Adapter for small pipes
E	Cable tie
F	Green/yellow tube
G	CS-100 cold-applied core sealer
H	JS-100 transition
I	1" locknut
J	Terminal block

Gland entry kit

Catalog No.	Part No.	Description
C75-100-A	000539-000	NEMA 4X-rated gland kit

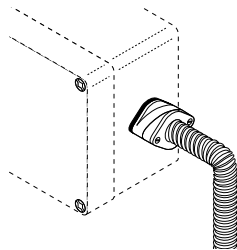

A NEMA 4X-rated gland kit used to transition heating cables into a junction box when making connections off of a pipe or tank. It may be used for power, splice, or tee connections. The C75-100-A is for use with Raychem BTV, QTVR, XTV, KTV,¹ and LBTV2-CT² self-regulating heating cables. The kit does not include the junction box, flexible tubing, or tape, which are required to make a complete connection.

¹ For KTV only, order PMK-GP-10 grommet (P/N 700823).

² For LBTV2-CT only, order HCS-100-A heat-shrink core sealer (P/N 257649) and PMK-GK-10 grommet (P/N 222724).

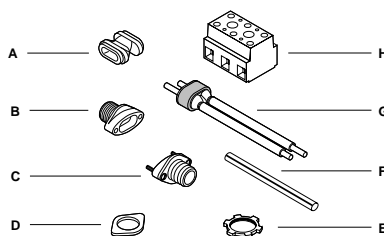

Kit Contents

Item	Description
A	Red grommet
B	Gland with threaded inserts
C	Gland with screws
D	Gland gasket
E	Locknut
F	Green/yellow heat-shrinkable tube
G	CS-100 core sealer
H	Terminal block

Attachment products

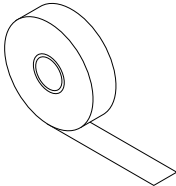
	Catalog No.	Part No.	Description
	GT-66	C77220-000	66-ft (20-m) roll of glass tape for attaching heating cable to pipe. Not for stainless steel pipes or for installation temperatures below 40°F.

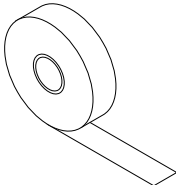
	GS-54	C77221-000	54-ft (16.5-m) roll of glass tape for attaching heating cable to pipe. For stainless steel pipes and for any installation below 40°F.
---	--------------	------------	---

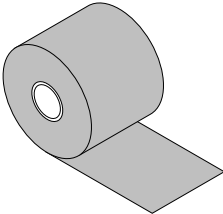
	AT-180	158139-000	180-ft (55-m) roll of aluminum tape for attaching heating cables and thermostat sensors to pipes and tanks.
--	---------------	------------	---

	CT-CABLE-TIE	C77261-000	Plastic cable ties (100 per box) offer an alternative method of attaching heating cable to pipes up to 3 in (75 mm) in diameter.
---	---------------------	------------	--

Pipe Straps		Used to secure connection components and brackets to pipes. Order by pipe diameter, as follows:	
PS-01	C77211-000	1/4—1 in	(6–25 mm)
PS-03	C77212-000	1—3 in	(25–75 mm)
PS-10	C77213-000	3—10 in	(75–250 mm)
PS-20	C77216-000	10—20 in	(250–500 mm)

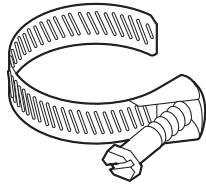

Labels

	Catalog No.	Part No.	Description
	ETL-ENGLISH	C77203-000	"Electric-traced" label for identifying traced pipes and tanks.

Brackets, Adapters

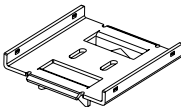
	Catalog No.	Part No.	Description
	SB-100-SP	800679-000	Adapter for mounting E-100, E-100-L, JBS-100, and JS-100 connection components on 1-in (25-mm) and smaller pipes (included in kits mentioned).

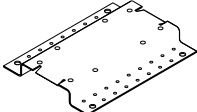
	SB-100-T	279613-000	Bracket for mounting JBS-100, E-100, and E-100-L on a tank surface.
--	-----------------	------------	---

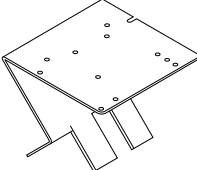
	UMB	263757-000	Universal mounting bracket for mounting thermostats and other equipment on a pipe.
---	------------	------------	--

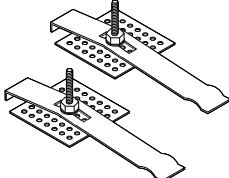
	BCK-35	C77215-000	Thermostat bulb clamp kit for attaching thermostat bulb to tank wall.
---	---------------	------------	---

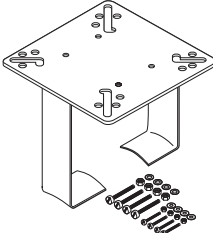
	JB-SB-25	471139-000	Stainless steel mounting bracket for RAYSTAT-EX-03-A thermostat.
---	-----------------	------------	--

Heat-Tracing System Worksheet

	Product Catalog Number	Quantity Required
Step 1: Select heating cable. Select appropriate heating cable for application. To aid in component selection, list: Pipe length Pipe size Pipe material		ft
Step 2: Select system components. Junction box Splice kit Tee kit End seal kit		ea.
Select accessories. Support bracket Tape Labels		ea.
Select controls. Thermostat to suit application		ea.

Step 3:

Contact your local Raychem representative to place your order.

Data Sheets

Data sheets with detailed product specifications are provided for the following components:

JBS-100	Single-entry power connection with junction box
JBM-100	Multiple-entry power/splice/tee connection with junction box
T-100	Splice or tee connection kit
E-100	High-profile end seal
E-100-L	High-profile end seal with light

The JBS-100 kit is designed to connect power to one Raychem BTV, QTVR, XTV, or KTV self-regulating heating cable and is approved by FM, CSA, and PTB for use in hazardous locations.

The JBS-100 integrates the functions of both connection kits and insulation entries. The rugged stand protects the heating cable and allows for up to 100 mm (4") of thermal insulation.

The new core sealing boot does not require a heat gun or torch for the installation (no hot work permit necessary). The noncuring sealant in the boot allows easy installation and facilitates maintenance.

Innovative cage clamp terminals from WAGO provide fast installation and safe, reliable, maintenance-free operation.

Compared to existing systems, this connection kit significantly reduces installation time.

The kit is offered in three versions, customized for local installation. Each kit contains all the necessary materials for a complete installation except for the pipe straps, which must be ordered separately.

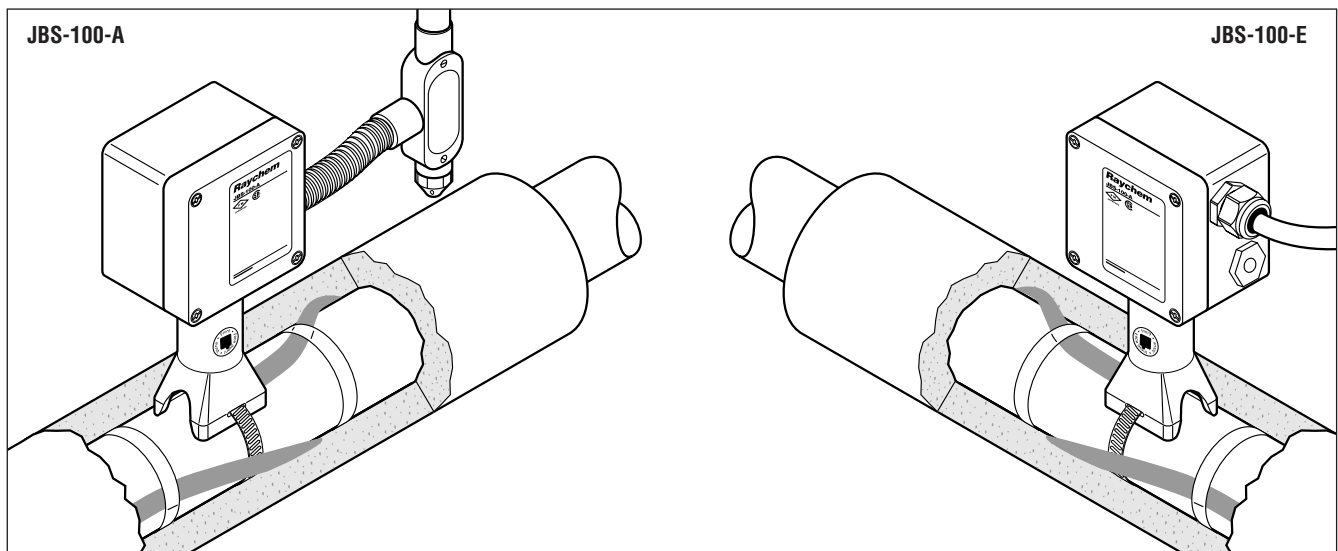

	JBS-100-A	JBS-100-E	JBS-100-EP
Description	This kit is for use in North America and has one through-hole for use with 3/4" conduit. A conduit drain is provided to prevent condensate from collecting in the box.	This kit is for use in Europe and provides two M25 threaded entries, one stopping plug, and one plastic power cable gland.	This kit is for use in Europe and provides two M25 threaded entries, an earthing plate, and an external earthing stud. It is designed for use with armored cables.
Kit contents	1 junction box with terminals 1 stand 1 core sealer 1 braid insulator 1 3/4" conduit drain 1 adapter for small pipes	1 junction box with terminals 1 stand 1 core sealer 1 braid insulator 1 M25 gland for power cable 8–17 mm in diameter 1 M25 stopping plug 1 adapter for small pipes	1 junction box with terminals, earth plate, and stud 1 stand 1 core sealer 1 braid insulator 1 M25 stopping plug 1 adapter for small pipes

Approvals

Hazardous Locations



Class I, Div. 2,
Groups B, C, D
Class II, Div. 1 and 2,
Groups E, F, G
Class III



CLI, ZN1, AEx e IIC



II 2 G EEx e II
PTB 97 ATEX 1058 U

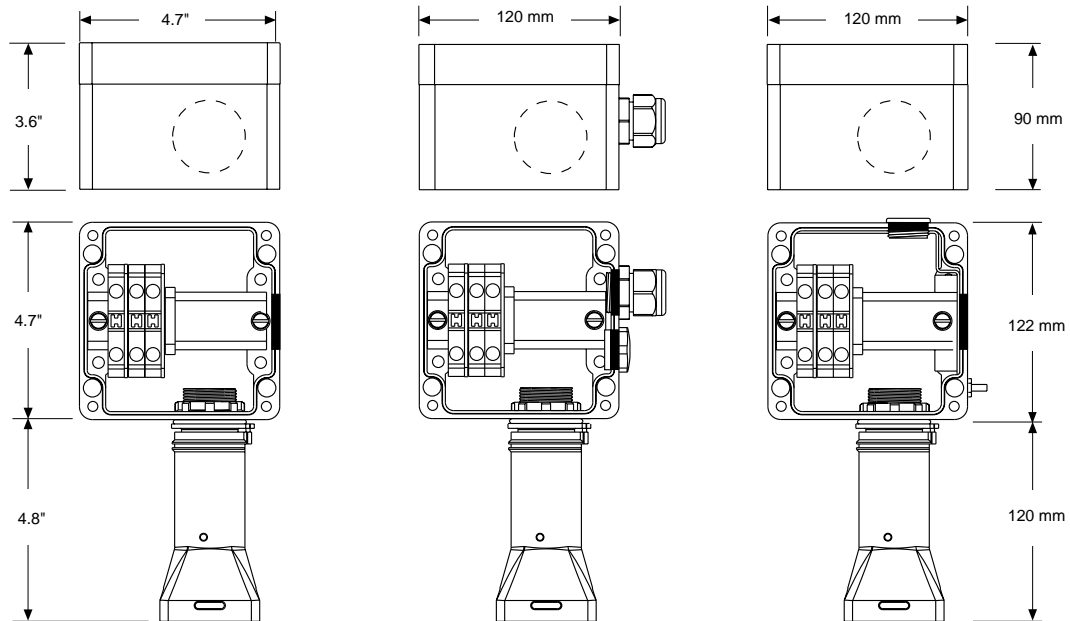

II 2 G EEx e II
PTB 97 ATEX 1058 U

JBS-100-A**JBS-100-E****JBS-100-EP****Dimensions (nominal)****Raychem product specifications**

Heating cable capability	BTV-CR, BTV-CT, QTVR-CT, XTV-CT, KTV-CT		
Ingress protection	NEMA Type 4X	IP67	IP67
Entries	1 x 3/4"	2 x M25	2 x M25
Min. installation temperature	-40°F (-40°C)	-40°F (-40°C)	-40°F (-40°C)
Min. usage temperature	-60°F (-75°C)	-60°F (-75°C)	-60°F (-75°C)
Max. pipe temperature	420°F (215°C)	420°F (215°C)	420°F (215°C)
Terminals	WAGO 284 series (EEx e) 2 line, 1 ground	WAGO 284 series (EEx e) 1 phase, 1 neutral, 1 earth	WAGO 284 series (EEx e) 1 phase, 1 neutral, 1 earth
Max. conductor size	8 AWG stranded	10 mm ² stranded, 10 mm ² solid	10 mm ² stranded, 10 mm ² solid
Max. operating voltage	277 Vac	277 Vac	277 Vac
Max. continuous operating current	50-A heating cable circuit	50-A heating cable circuit	50-A heating cable circuit
Deluge testing	Passed Shell UK requirements	Passed Shell UK requirements	Passed Shell UK requirements

Materials of construction

Enclosure, lid, and stand	Electrostatic-charge-resistant glass-filled engineering polymers, black	Electrostatic-charge-resistant glass-filled engineering polymers, black	Electrostatic-charge-resistant glass-filled engineering polymers, black
Lid screws	Stainless steel	Stainless steel	Stainless steel
Lid gasket	Silicone rubber	Silicone rubber	Silicone rubber
Earth continuity plate	N/A	N/A	Steel, zinc plated, and yellow chromated

Ordering details

Part description	JBS-100-A	JBS-100-E	JBS-100-EP
Raychem part number	085947-000	829939-000	158251-000
Weight	2.5 lb	1.2 kg	1.3 kg

The JBM-100 kit is designed to splice, tee, or connect power to as many as three Raychem BTV, QTVR, XTV, or KTV self-regulating heating cables and is approved by FM, CSA, and PTB for use in hazardous locations.

The JBM-100 integrates the functions of both connection kits and insulation entries. The rugged stand protects the heating cable and allows for up to

100 mm (4") of thermal insulation. The new core sealing boot does not require a heat gun or torch for the installation (no hot work permit necessary). The noncuring sealant in the boot allows easy installation and facilitates maintenance.

Innovative cage clamp terminals from WAGO provide fast installation and safe, reliable, maintenance-free operation.

Compared to existing systems, this connection kit significantly reduces installation time.

The kit is offered in three versions, customized for local installation. Each kit contains all the necessary materials for a complete installation except for the pipe straps, which must be ordered separately.

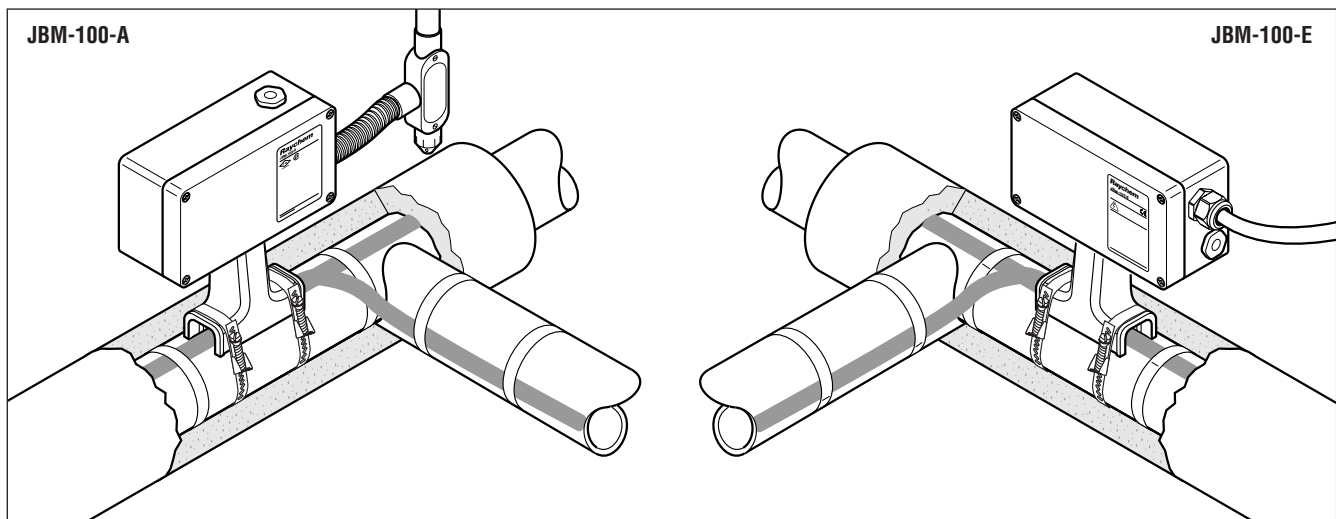

	JBM-100-A	JBM-100-E	JBM-100-EP
Description	This kit is for use in North America and has two 3/4" through holes for use with 3/4" conduit. Two stopping plugs are supplied in the kit. A conduit drain is provided to prevent condensate from collecting in the box.	This kit is for use in Europe and provides two M25 threaded entries, two stopping plugs, and one plastic power cable gland.	This kit is for use in Europe and provides two M25 threaded entries, an earthing plate, and an external earthing stud. It is designed for use with armored cables.
Kit contents	1 junction box with terminals 1 stand 3 core sealers 3 braid insulators 1 3/4" conduit drain 1 adapter for small pipes	1 junction box with terminals 1 stand 3 core sealers 3 braid insulators 1 M25 gland for power cable 8–17 mm in diameter 2 M25 stopping plugs 1 adapter for small pipes	1 junction box with terminals, earth continuity plate, and stud 1 stand 3 core sealers 3 braid insulators 2 M25 stopping plugs 1 adapter for small pipes

Approvals

Hazardous Locations



Class I, Div. 2,
Groups B, C, D
Class II, Div. 1 and 2,
Groups E, F, G
Class III



Groups E, F, G
Class III



CLI, ZN1, AEx e IIC



II 2 G EEx e II
PTB 98 ATEX 1021 U

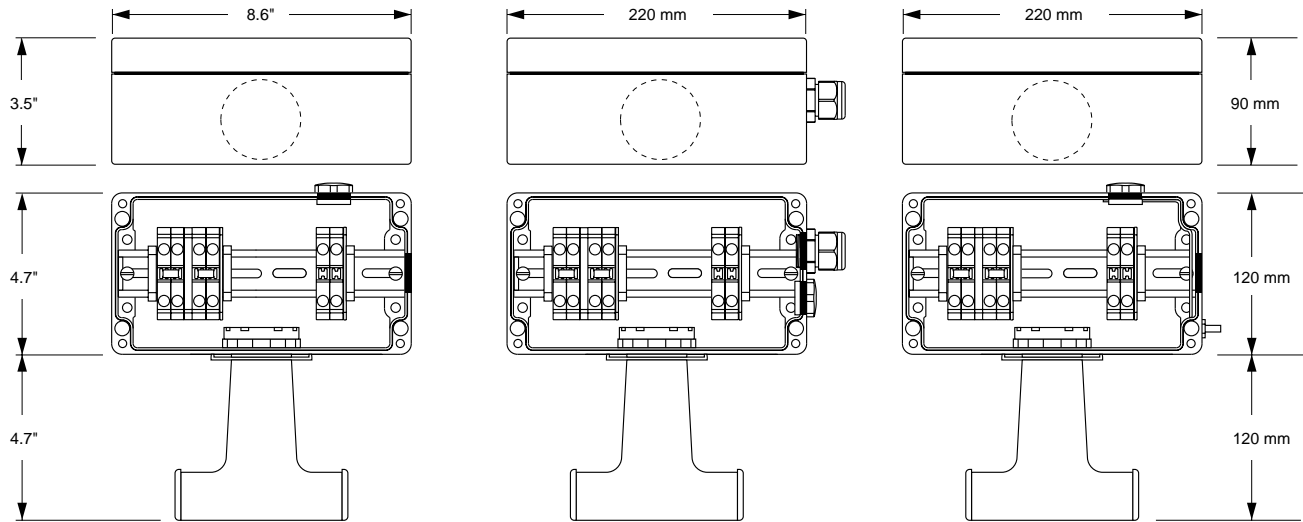

II 2 G EEx e II
PTB 98 ATEX 1021 U

JBM-100-A**JBM-100-E****JBM-100-EP****Dimensions (nominal)****Raychem product specifications**

Heating cable capability	BTV-CR, BTV-CT, QTVR-CT, XTV-CT, KTV-CT		
Ingress protection	NEMA Type 4X	IP66	IP66
Entries	2 x 3/4"	2 x M25	2 x M25
Min. installation temperature	-40°F (-40°C)	-40°F (-40°C)	-40°F (-40°C)
Min. usage temperature	-60°F (-75°C)	-60°F (-75°C)	-60°F (-75°C)
Max. pipe temperature	420°F (215°C)	420°F (215°C)	420°F (215°C)
Terminals	WAGO 284 series (EEx e) 4 line, 2 ground	WAGO 284 series (EEx e) 2 phase, 2 neutral, 2 earth	WAGO 284 series (EEx e) 2 phase, 2 neutral, 2 earth
Max. conductor size	8 AWG stranded	10 mm ² stranded, 10 mm ² solid	10 mm ² stranded, 10 mm ² solid
Max. operating voltage	277 Vac	277 Vac	277 Vac
Max. continuous operating current	50-A heating cable circuit	50-A heating cable circuit	50-A heating cable circuit
Deluge testing	Passed Shell UK requirements	Passed Shell UK requirements	Passed Shell UK requirements

Materials of construction

Enclosure, lid, and stand	Electrostatic-charge-resistant glass-filled engineering polymers, black	Electrostatic-charge-resistant glass-filled engineering polymers, black	Electrostatic-charge-resistant glass-filled engineering polymers, black
Lid screws	Stainless steel	Stainless steel	Stainless steel
Lid gasket	Silicone rubber	Silicone rubber	Silicone rubber
Earth continuity plate	N/A	N/A	Steel, zinc plated, and yellow chromated

Ordering details

Part description	JBM-100-A	JBM-100-E	JBM-100-EP
Raychem part number	179955-000	831519-000	986415-000
Weight	4.3 lb	1.9 kg	2.1 kg

The T-100 is an above-insulation splice or tee kit, designed for use with up to three Raychem BTV, QTVR, XTV, or KTV self-regulating heating cables. It is approved by FM, CSA, and PTB for use in hazardous locations.

The rugged stand protects the heating cable and allows for up to 100 mm (4") of thermal insulation.

The new core sealing boot does not require a heat gun or torch for the installation (no hot work permit necessary). The noncuring sealant in the boot allows easy installation and facilitates maintenance.

Compared to existing systems, the T-100 significantly reduces installation and maintenance time and effort.

Each kit contains all the necessary materials for a complete installation except for the pipe straps, which must be ordered separately.

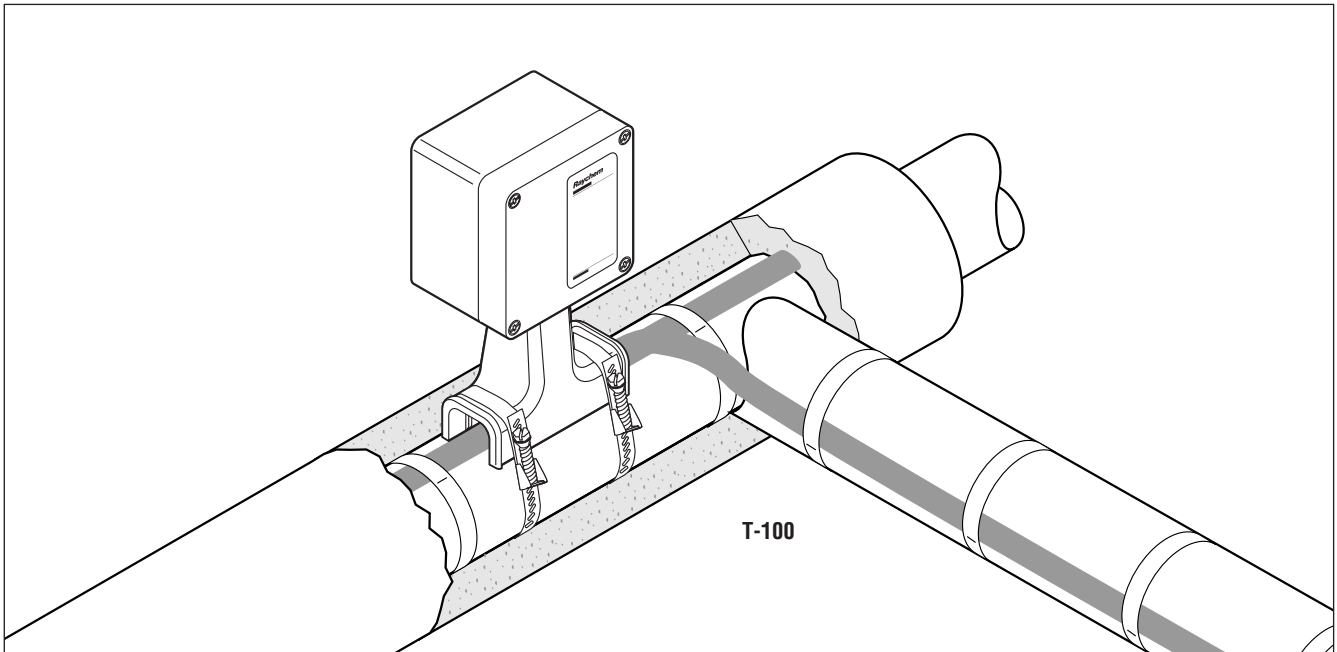

Description

This kit is an above-insulation splice/tee, appropriate for use worldwide with no requirements for local customization.

Kit contents

Note: Order appropriate pipe straps separately (two straps per kit).

- 1 splice/tee enclosure and lid
- 1 stand assembly
- 3 core sealers
- 3 braid insulators
- 1 adapter for small pipes
- 3 compression crimps
- 3 crimping insulating tubes

Approvals

Hazardous Locations



Class I, Div. 2, Groups B, C, D
Class II, Div. 1 and 2, Groups E, F, G
Class III



II 2 G EEx e II
PTB 98 ATEX 1020 U



CLI, ZN1, AEx e IIC

Dimensions (nominal)

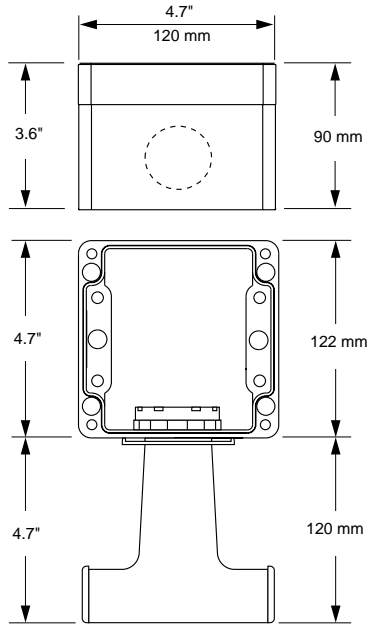

Specifications

Heating cable capability	BTV-CR, BTV-CT, QTVR-CT, XTV-CT, KTV-CT
Ingress protection	NEMA Type 4X/IP67
Min. installation temperature	-40°F (-40°C)
Min. usage temperature	-75°F (-60°C)
Max. pipe temperature	420°F (215°C)
Max. operating voltage	277 Vac
Max. continuous operating current	50-A heating cable circuit
Deluge testing	Passed Shell UK requirements

Materials of construction

Enclosure, lid, and stand	Electrostatic-charge-resistant glass-filled engineering polymers, black
Lid screws	Stainless steel
Lid gasket	Silicone rubber

Ordering details

Part description	T-100
Raychem part number	447379-000
Weight	2.5 lb/1.2 kg

The E-100 is a NEMA 4X-rated end seal kit for Raychem BTV, QTVR, KTV, and XTV heating cables. Once installed, these end seals are easily reentered for maintenance; the heating cable can be accessed without removing the end seal.

Quick and easy to install

Installation is extremely fast and no grommet selection is required. All parts are captive and are correctly positioned at the time of installation. The only tools needed are a utility knife, wire cutters, and a screwdriver; no heat source is required. To reduce the risk of tampering, a tool-only reentry feature is offered.

Super sealed and corrosion resistant

The combination of compression grommet and O-rings provides the E-100 with a complete water seal. The heating-cable core and bus wires are insulated and sealed separately from the braid by means of a sealant-filled boot. The NEMA 4X-rated E-100 is resistant to chemical and salt corrosion.

Exceptionally rugged

Using the latest in polymer technology, the E-100 is designed for extreme durability during and after installation. The E-100 meets or exceeds IEEE and European Norm standards for impact resistance and ruggedness.

Easy to locate

The high-profile E-100 end seal is mounted on the pipe, and projects through the thermal insulation and cladding for easy visibility. A brightly colored "leash" holds the cap captive to the stand.

Reenterable

With the E-100 end seal, heating-cable bus wires and grounding braid are easily accessed for voltage and continuity checks. Simply unscrew the E-100 cap and remove the reusable sealing boot; there is no need to completely disassemble or remove the end seal.

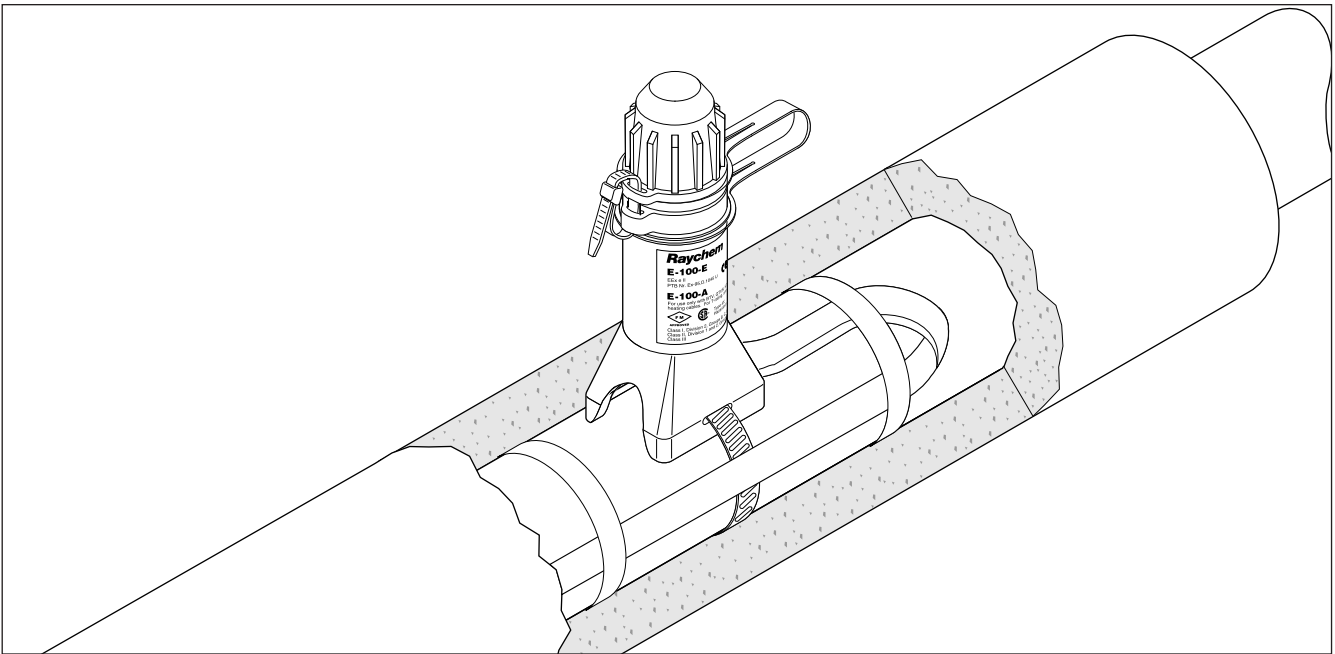

Kit contents

Note: Order appropriate pipe strap separately.

1 end seal
1 end seal label
1 cable tie

Approvals

Hazardous Locations



Class I, Div. 2, Groups A, B, C, D
Class II, Div. 1 and 2, Groups E, F, G
Class III



CLI, ZN1, AEx e IIC

Dimensions

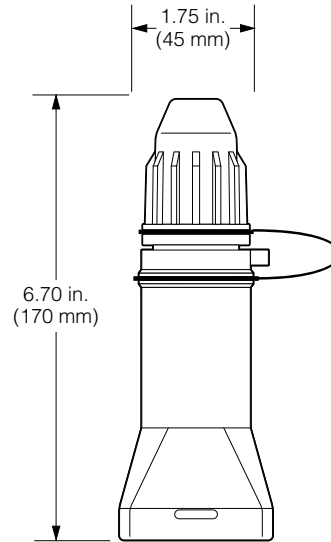

Specifications

Heating cable compatibility	BTV-CR/-CT, QTVR-CT, XTV-CT, KTV-CT; not LBTV or M-wire
Ingress protection	NEMA Type 4X, IP65
Min. installation temperature	-40°F (-40°C)
Max. pipe temperature	419°F (215°C)
Materials	High-performance glass-filled engineering polymers
Impact resistance	10 ft-lb at -22°F (-30°C) (IEEE 515-5.1.6) 7 joules after 1 month thermal aging (EN 50 014-23.4.7.2)
Flammability	IEEE 515-5.3.4
Dust exclusion	IEC 529-5.6.2
Cable creepage	FM 3820-5.2.5, EN 50 014-B.1.3
Tools required	Wire cutters, utility knife, screwdriver
Max. thickness pipe insulation	4 in (100 mm)

Ordering details

High-profile end seal kit	
Part description	E-100-A
Raychem part number	046567-000
Weight	0.5 lb
Replacement sealing boots (5 per pack)	
Part description	E-100-BOOT-5/PACK
Raychem part number	281053-000
Weight	0.25 lb

The E-100-L is a high-profile end seal with a signal light module. This unit is approved for use with most Raychem heating cables and has worldwide approvals for use in ordinary and hazardous areas. These rugged end seals are resistant to impact, high temperatures, and chemical and UV attack. Sealing is done separately with O-rings and a sealant-filled boot.

The light module uses an array of super-bright LEDs for excellent visibility and long life. The robust industrial-grade electronics are encapsulated to reliably seal out moisture and dust.

The light module can be retrofitted into previously installed E-100 and PMK-RE end seals, and the light module is replaceable.

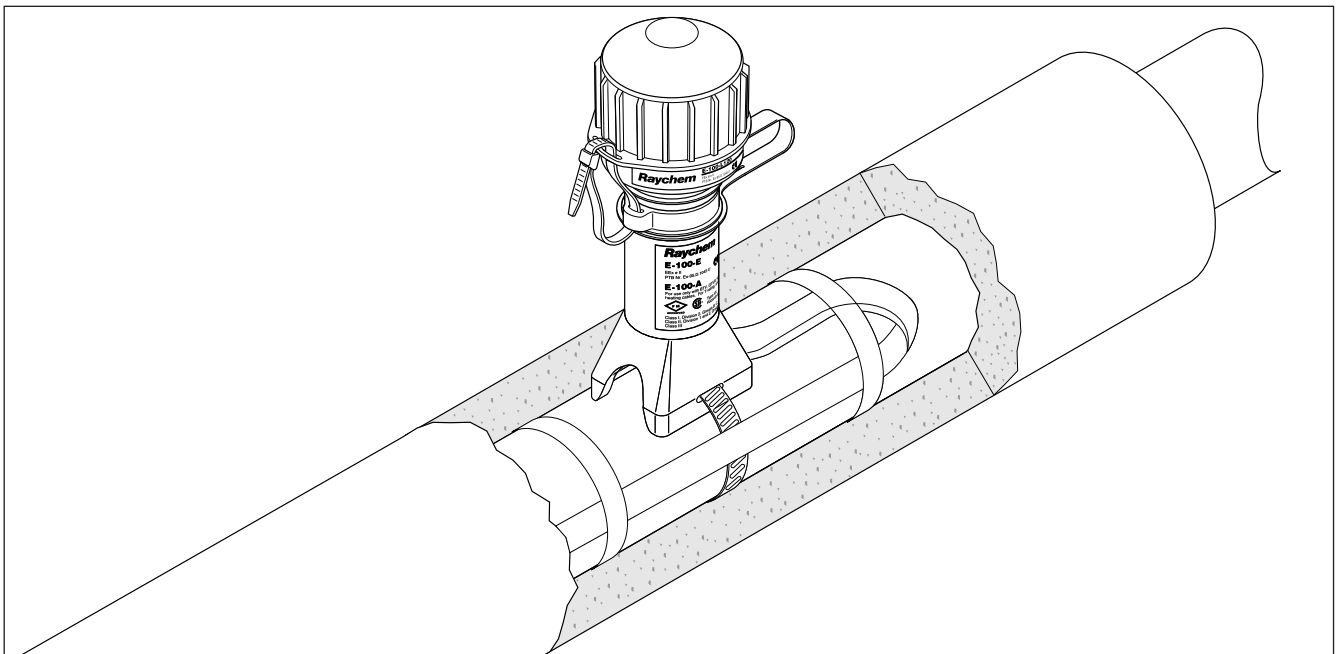

Kit contents

Note: Order appropriate pipe strap separately.

1 end seal with lighted cap
1 end seal label
1 cable tie

Approvals

Hazardous Locations



Class I, Div. 2, Groups A, B, C, D
Class II, Div. 1 and 2, Groups E, F, G
Class III



CLI, ZN1, AEx e IIC

Dimensions

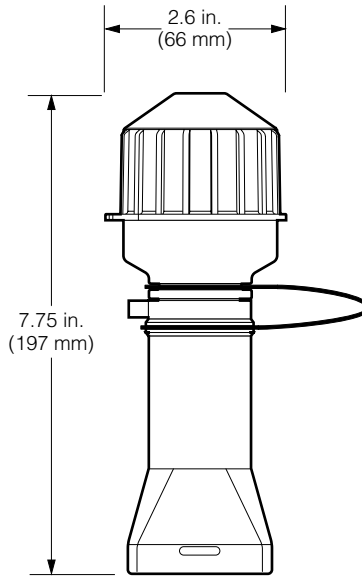

Specifications

Heating cable compatibility	BTV-CR/-CT, QTVR-CT, XTV-CT, KTV-CT; not LBTV or M-wire	
Ingress protection	NEMA Type 4X, IP65	
Min. installation temperature	-40°F (-40°C)	
Max. pipe temperature	419°F (215°C)	
Min./max. ambient temperature	-40°F to 105°F (-40°C to 40°C)	
Materials	High-performance engineering polymers	
Impact resistance	IEEE 515 EN 50 014	10 ft-lb at -40°F (-40°C) ≥ 7 joules
Light source	Super-bright light emitting diodes (LEDs)	
Light source power supply	Linear (non-switching)	
Power consumption	< 2 watts	
Electromagnetic compatibility	Immunity Emissions	Complies with EN 50 082-2:1995 Complies with EN 50 081-1:1991 (commercial and light industrial classes) and meets requirements of FCC, Part 15, Class B
	CE	
Vibration	IEC 68-2-6	20 m/s ² , 10–150 Hz
Shock	IEC 68-2-27	500 m/s ² , 11 ms
Tools required	Wire cutters, utility knife, screwdriver, crimp tool	
Max. thickness pipe insulation	4 in (100 mm)	

Ordering details

Complete lighted end seal kit (requires one pipe strap, not supplied)	100–120 Vac*	Red LEDs	E-100-L1-A RPN 583377 (1.3 lb)
	200–277 Vac*	Red LEDs	E-100-L2-A RPN 478767 (1.3 lb)
Replacement/retrofit lighted end seal kit (for use with existing PMK-RE or E-100)	100–120 Vac*	Red LEDs	E-100-LR1-A RPN 552225 (0.9 lb)
	200–277 Vac*	Red LEDs	E-100-LR2-A RPN 874485 (0.9 lb)

*Voltage tolerance: ± 10%, 50/60 Hz



AutoSense, MoniTrace, Raychem, RayStat, TraceCalc, and TraceGuard are trademarks of Raychem Corporation.

All information, including illustrations, is believed to be reliable. Users, however, should independently evaluate the suitability of each product for their application. Raychem makes no warranties as to the accuracy or completeness of the information, and disclaims any liability regarding its use. Raychem's only obligations are those in the Raychem Standard Terms and Conditions of Sale for this product, and in no case will Raychem be liable for any incidental, indirect, or consequential damages arising from the sale, resale, use, or misuse of the product. Specifications are subject to change without notice. In addition, Raychem reserves the right to make changes—without notification to Buyer—to processing or materials that do not affect compliance with any applicable specification.

TE&I Division

Raychem Corporation
300 Constitution Drive
Menlo Park, California 94025-1164
Tel (800) 545-6258
Fax (800) 611-2323
Fax-on-Demand (800) 329-4494
ciinfo@raychem.com
www.raychem.com

Raychem Canada Limited
Toronto, Ontario M5H 4A2
Canada
Tel (800) 988-5171
Fax (800) 988-5172

Raychem S.A.I.C.
Carlos Pellegrini 1163, Piso 7
1009 Capital Federal
Buenos Aires, Argentina
Tel (54) 1/394-5150
Fax (54) 1/326-9985