

Discrete Input Module

IC670MDL240

GFK-1093E
June 1997

120 VAC Grouped Input Module

The 120VAC Grouped Input Module (IC670MDL240) provides a single group of 16 discrete inputs.

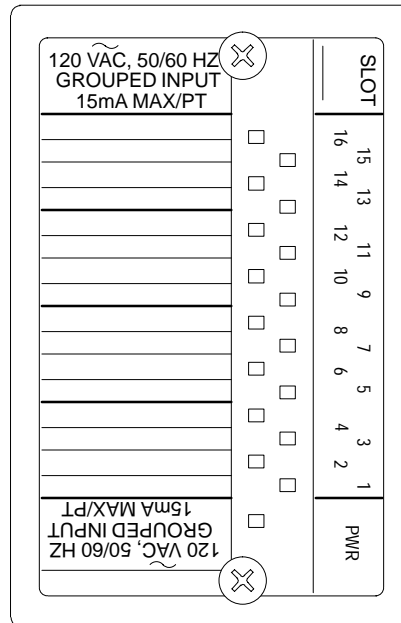

46380

Power Sources

The module receives power from the Bus Interface Unit for its own operation.

An external 120VAC supply is needed to power the input devices. Module inputs respond to voltage levels from 0 VAC to 132 VAC.

LEDs

Individual LEDs, visible through the transparent portion of the module top, indicate the on/off status of each input. The PWR LED is on when backplane power is present.

Host Interface

Intelligent processing for this module is performed by the Bus Interface Unit or elsewhere in the system. This includes configuring features such as input defaults and fault reporting. The module has 16 bits (two bytes) of discrete input data. A Bus Interface Unit is required to provide this input data to the host and/or local processor.

GFK-1093E
June 1997

120 VAC Grouped Input Module

Module Operation

A network of resistors and capacitors establishes input thresholds and provides input filtering. Optoisolators provide isolation between the field inputs and the module's logic components. Data from all 16 inputs is placed into a data buffer. The module's circuit LEDs show the current states of the 16 inputs in this data buffer.

Parallel-to-serial converters change input data from the data buffer into the serial format needed by the Bus Interface Unit.

After checking the Board ID and verifying that the module is receiving appropriate logic power from the Bus Interface Unit (which is reflected by the state of the module's Power LED), the Bus Interface Unit then reads the filtered, converted input data.

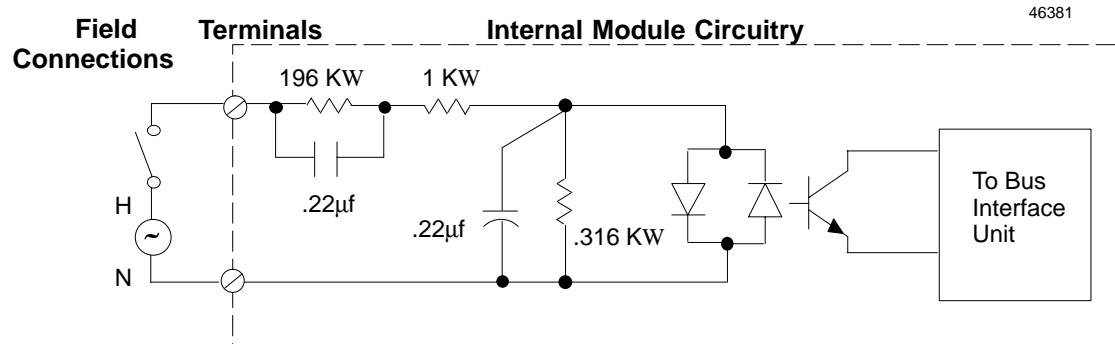

Module Specifications

Module Characteristics	
Rated Voltage	120 VAC
Input Voltage Range	0-132 VAC (47-63 Hz)
User Input Current	15 mA per point @ 120 VAC
Indicators	1 LED per point shows individual point status PWR LED indicates backplane power is present
Isolation: User input to logic, user input to frame ground, group to group	250 VAC continuous, 1500 VAC for 1 minute. No isolation between individual points in a group.
Current Drawn from Bus Interface Unit Power Supply	77 mA maximum
Input Characteristics	
Input Impedance	8.6K typical (reactive)
On state voltage Off state voltage	70 VAC to 120 VAC 0 VAC to 20 VAC
On state Current Off state Current	5mA to 15mA 0mA to 2.5mA
On response time Off response time	12ms typical, 20 ms maximum 25ms typical, 40 ms maximum

120 VAC Grouped Input Module

GFK-1093E
June 1997

Keying Locations

Optional keying locations for the 120VAC Grouped Input Module are shown below.

KeyingLocations									
A	B	C	D	E	F	G	H	J	K
	✓			✓		✓	✓		

Field Wiring

I/O Terminal Block wiring assignments for this module are shown below.

The Terminal Block with box terminals has 25 terminals for each module, each of which accommodates one AWG #14 (avg 2.1mm² cross section) to AWG #22 (avg 0.36mm² cross section) wire, or two wires up to AWG #18 (avg. 0.86mm² cross section). When an external jumper is used, the wire capacity is reduced from AWG #14 (2.10mm²) to AWG #16 (1.32mm²).

The I/O Terminal Block with barrier terminals has 18 terminals per module. Each terminal can accommodate one or two wires up to AWG #14 (avg 2.1mm² cross section).

The I/O Terminal Block with Connectors has one 20-pin male connector per module. The mating connector is Amp part number 178289-8. Any tin-plated contact in the AMP D-3000 series can be used with the connector (Amp part number 1-175217-5 for high contact force receptacle for 20-24 gauge (0.20-0.56mm²) wires), 1-175218-5 for high contact force receptacle for 16-20 gauge (0.56-1.42mm²).

Connection to the A terminals is optional. They can be used as shown on the next page.

<p>I/O Terminal Block with Box Terminals (IC670CHS002 and 102)</p> <p>46383</p> <p>Input 16 Input 14 Common Input 12 Input 10 Common Input 8 Input 6 Common Input 4 Input 2 Common N N</p> <p>16 14 E8 12 10 E6 8 6 E4 4 2 E2 B2 B1 E1 A2 A1</p> <p>Input 15 Input 13 Input 11 Input 9 Input 7 Input 5 Input 3 Input 1 Common NC* NC*</p> <p>Terminals E1, E2, E4, E6, and E8 are electrically connected together, A1 and A2 are electrically connected together, B1 and B2 are electrically connected together.</p>	<p>I/O Terminal Block with Barrier Terminals (IC670CHS001 and 101)</p> <p>46451</p> <p>Input 16 Input 14 Input 12 Input 10 Input 8 Input 6 Input 4 Input 2 N</p> <p>16 14 12 10 8 6 4 2 B 15 13 11 9 7 5 3 1 A</p> <p>Input 15 Input 13 Input 11 Input 9 Input 7 Input 5 Input 3 Input 1 NC*</p>	<p>I/O Terminal Block with Wire to Board Connectors (IC670CHS003 and 103)</p> <p>46530</p> <p>Input 11 Input 12 Input 13 Input 14 Input 15 Input 16 NC* NC* N N</p> <p>11 12 13 14 15 16 A2 A1 B2 B1 10 9 8 7 6 5 4 3 2 1</p> <p>Input 10 Input 9 Input 8 Input 7 Input 6 Input 5 Input 4 Input 3 Input 2 Input 1</p>
---	---	--

120 VAC Grouped Input Module

Wiring Examples with Auxiliary Terminal Blocks

If the module is installed on an I/O Terminal Block with Box Terminals or an I/O Terminal Block with Barrier Terminals, an Auxiliary Terminal Block may be required to provide additional wiring terminals. For the I/O Terminal Block with Wire to Board Connectors, external connection points are usually preferred, although an Auxiliary Terminal Block can be used..

Auxiliary Terminal Blocks have all terminals connected together internally. The Auxiliary Terminal Block with box terminals has 13 terminals, each of which accommodates one AWG # 14 (avg 2.1mm² cross section) to AWG #22 (avg 0.36mm² cross section) wire, or two wires up to AWG #18 (avg. 0.86mm² cross section). The Auxiliary Terminal Block with barrier terminals has nine terminals, each of which can accommodate one or two wires up to AWG #14 (avg 2.1mm² cross section).

The following illustration shows how an optional Auxiliary Terminal Block with Box Terminals can be used for power connections when installing this module on an I/O Terminal Block with Box Terminals.

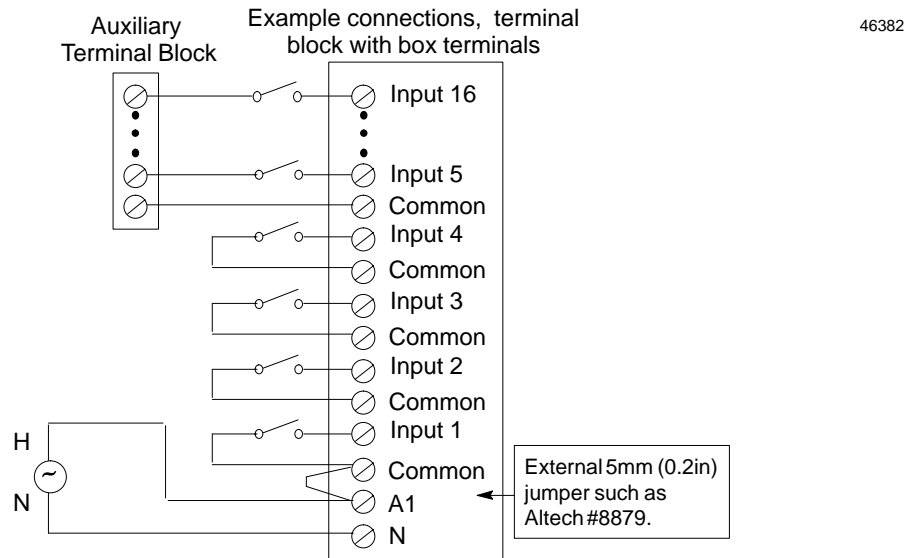

For an I/O Terminal Block with Barrier Terminals or an I/O Terminal Block with Wire to Board Connectors, an Auxiliary Terminal Block with Barrier Terminals might be connected as shown in the following example.

