

IC693APU300 High Speed Counter (HSC) Module

The High Speed Counter (IC693APU300) for the Series 90-30 PLC is a single-slot module which can be used in applications where pulse input rates exceed the input capability of the PLC or where too large a percentage of PLC processing capability would be required. The High Speed Counter provides direct processing of rapid pulse signals up to 80 KHz for industrial applications such as: meter proving, turbine flowmeter, velocity measurement, material handling, motion control and process control.

With direct processing, the High Speed Counter module is able to sense inputs, count, and respond with outputs without needing to communicate with a CPU. It can be configured to count either up or down, to count both up and down, or to count the difference between two changing values. The module can be configured to provide 1, 2, or 4 counters of differing complexity.

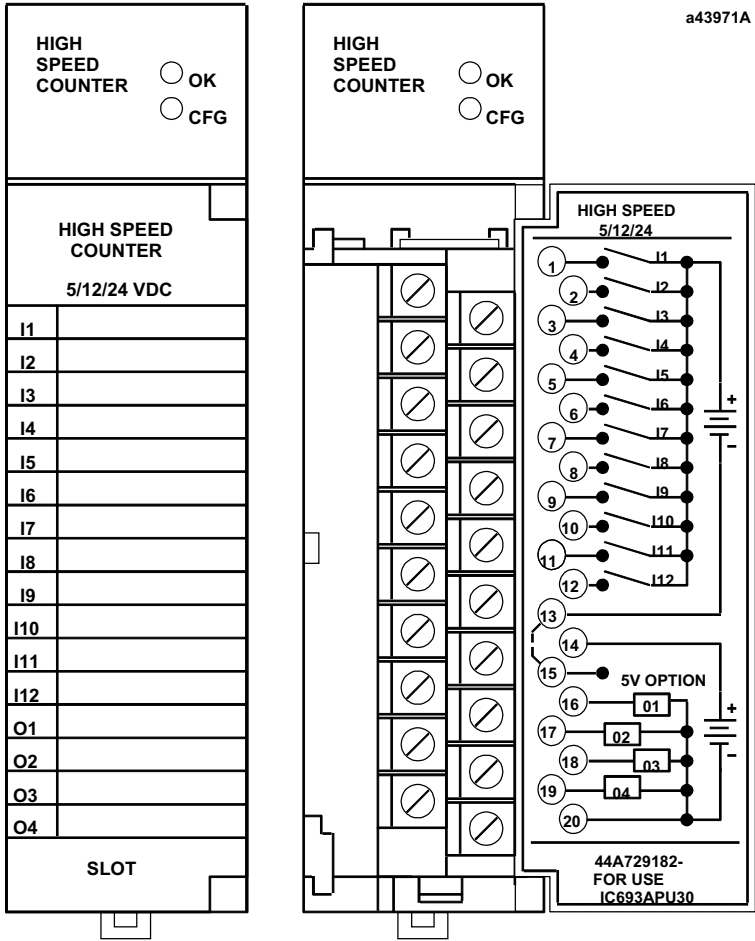

Figure 8-14. High Speed Counter (HSC)

The High Speed Counter can be installed in any Series 90-30 baseplate and is configured using the Hand-Held Programmer, Logicmaster 90-30/20, VersaPro software, or Logic Developer-PLC. Many features can also be configured from the user’s application program. There are no jumpers to be set on the module. Two LEDs at the top of the module indicate the operating status of the module and the status of configuration parameters.

For details on the HSC, refer to GFK-0293, *Series 90-30 High Speed Counter User’s Manual*.