

Chapter 8

Discrete Combination I/O Modules

120 Volt AC Input, Relay Output, 8 Inputs/8 Outputs IC693MAR590

The *120 volt AC Input/Relay Output* module for the Series 90-30 Programmable Logic Controller provides 8 input points with one common power input terminal, and 8 normally-open relay circuits in the same module. The input circuits are reactive (resistor/capacitor) inputs and are arranged as one group of 8 inputs. The output points are arranged in two groups of four points each. Each group has a common power output terminal.

Input characteristics are compatible with a wide range of user-supplied devices, such as: pushbuttons, limit switches, and electronic proximity switches. Current through an input results in a logic 1 in the input status table (%I). Power to operate the field devices must be supplied by the user. This module's input section requires an AC power source, it cannot be used with a DC power source.

The normally-open relay circuits are used for controlling output loads provided by the user. The output switching capacity of each output is 2 amps. The relay outputs can control a wide range of user-supplied load devices, such as: motor starters, solenoids, and indicators. Power for the internal relay circuits is provided by the +24 volt DC bus on the backplane. The user must supply the AC or DC power to operate field devices. There are no fuses on this module.

LED indicators which provide the ON/OFF status of each point are located at the top of the module. The LEDs are arranged in two horizontal rows with eight green LEDs in each row. The top row is labeled A1 through 8 (input points 1 through 8) and the bottom row is labeled B1 through B8 (relay output points 1 through 8). An insert goes between the inside and outside surface of the hinged door. The surface towards the inside of the module (when the hinged door is closed) has circuit wiring information, and circuit identification information can be recorded on the outside surface. The outside left edge of the insert is color-coded red to indicate a high-voltage module.

This module can be installed in any I/O slot of a 5 or 10-slot baseplate in a Series 90-30 PLC system.

Table 8-1. Specifications for IC693MAR590

Inputs	
Rated Voltage	120 volts AC
Input Voltage range	0 to 132 volts AC
Inputs per Module	8 (one group of eight inputs)
Isolation	1500 volts RMS between field and logic side 500 volts RMS between inputs
Input Current	12 mA (typical) at rated voltage
Input Characteristics	
On-State Voltage	74 to 132 volts AC
Off-State Voltage	0 to 20 volts AC
On-State Current	6 mA (minimum)
Off-State Current	2.2 mA (maximum)
On Response Time	30 ms typical
Off Response Time	45 ms typical
Outputs	
Rated Voltage	24 VDC, 120/240 VAC
Operating Voltage	5 to 30 volts DC 5 to 250 volts AC, 50/60 Hz
Outputs per Module	8 (two groups of four outputs each)
Isolation	1500 volts RMS between field and logic side 500 volts RMS between groups
Maximum Load ‡	2 amps maximum per output 4 amps maximum per common
Minimum Load	10 mA
Maximum Inrush	5 amps
On Response Time	15 ms maximum
Off Response Time	15 ms maximum
Internal Power Consumption	80 mA (all I/O on) from +5V backplane bus 70 mA (all outputs on) from relay +24V backplane bus

‡ Maximum load current is dependent on operating voltage as shown in the following table.

Refer to Appendix B for product standards and general specifications.

Table 8-2. Load Current Limitations for IC693MAR590

Operating Voltage	Maximum Current for Load Type		Typical Contact Life (number of Operations)
	Resistive	Lamp or Solenoid †	
240 VAC, 120 VAC, 24 VDC	2 amps	.6 amps	200,000
240 VAC, 120 VAC, 24 VDC	1 amp	.3 amps	400,000
240 VAC, 120 VAC, 24 VDC	.5 amps	.1 amp	800,000

† For inductive loads

Relay contact life, when switching inductive loads, will approach resistive load contact life if suppression circuits are used. The following figures are examples of typical suppression circuits for AC and DC loads. The 1A, 100V diode shown in the DC load typical suppression circuit is an industry standard 1N4934. The resistor and capacitor shown for AC load suppression are standard components, available from most electronics distributors.

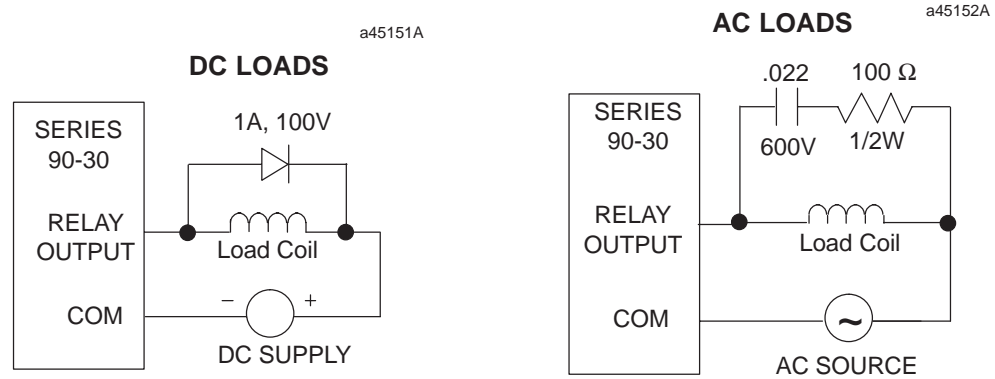

Field Wiring Information

The following figure provides wiring information for connecting user supplied input and load devices, and power source(s) to the 120 Volt Input/Relay Output module.

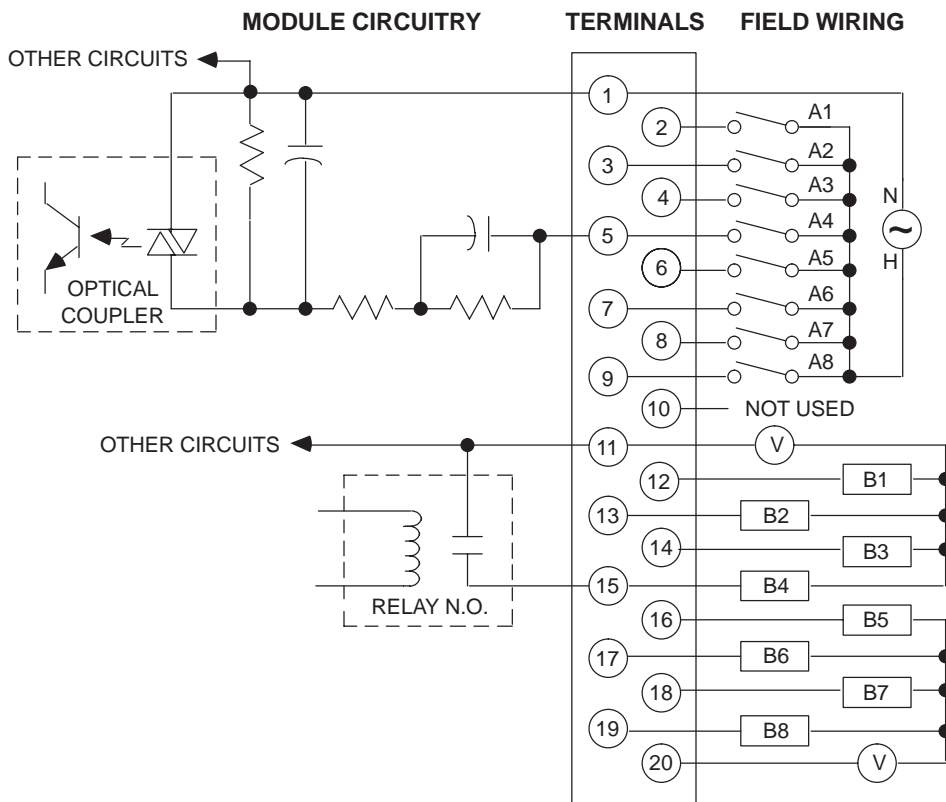

Figure 8-1. Field Wiring 120 VAC Input/Relay Output Module - IC693MAR590