

## 120/240 Volt AC Isolated Output - 2 Amp, 5 Point IC693MDL390

The *120/240 volt, 2 Amp Isolated AC Output* module for the Series 90-30 Programmable Logic Controller provides 5 isolated output points with each point having a separate common. Each output circuit is isolated from the others relative to the AC power source; commons are not tied together inside the module. This allows each output circuit to be used on different phases of the AC supply, or they can be powered from the same supply. Outputs are individually fused with a 3 amp fuse and an RC snubber is provided for each output to protect against transient electrical noise on the power line. This module provides a high-degree of inrush current (greater than 10x the rated current) making the outputs suitable for controlling a wide range of inductive and incandescent loads. AC Power to operate the loads connected to the outputs must be supplied by the user. ***This module requires an AC power source, it can not be used with a DC power source.***

LED indicators which provide the ON/OFF status of each point are located at the top of the module. These LEDs are arranged in two horizontal rows with eight green LEDs in each row and a red LED centered between and to the right of the two rows. This module uses the first five LEDs, labeled A1 through 5 in the top row for output status. The red “F” LED is a blown fuse indicator that turns ON if any fuse should blow. An insert goes between the inside and outside surface of the hinged door. The surface towards the inside of the module (when the hinged door is closed) has circuit wiring information, and circuit identification information can be recorded on the outside surface. The outside left edge of the insert is color-coded red to indicate a high-voltage module. This module can be installed in any I/O slot in a Series 90-30 PLC system, ***and it should be configured as an 8 point output with programs referencing the five least significant bits.***

**Table 7-6. Specifications for IC693MDL390**

<b>Rated Voltage</b>	120/240 volts AC
<b>Output Voltage Range</b>	85 to 264 volts AC, 50/60 Hz
<b>Outputs per Module</b>	5 (each output isolated from the others)
<b>Isolation</b>	1500 volts between field side and logic side 500 volts between each output
<b>Output Current †</b>	2 amps maximum per point 5 amps maximum per module at 45° C (113° F) 2 amps maximum per module at 60° C (140° F)
<b>Output Characteristics</b>	
<b>Inrush Current</b>	25 amps maximum for one cycle
<b>Minimum Load Current</b>	100 mA
<b>Output Voltage Drop</b>	1.5 volts maximum
<b>Output Leakage Current</b>	3 mA maximum at 120 volts AC 6 mA maximum at 240 volts AC
<b>On Response Time</b>	1 ms maximum
<b>Off Response Time</b>	1/2 cycle maximum
<b>Power Consumption</b>	110 mA (all outputs on) from 5 volt bus on backplane

† Maximum load current is dependent upon ambient temperature as shown in graph on following page.

**Refer to Appendix B for product standards and general specifications.**

### IC693MDL390 Output Module Field Wiring Information

The following figure provides wiring information for connecting user supplied input devices and power source to the 120/240 volt isolated AC output module.

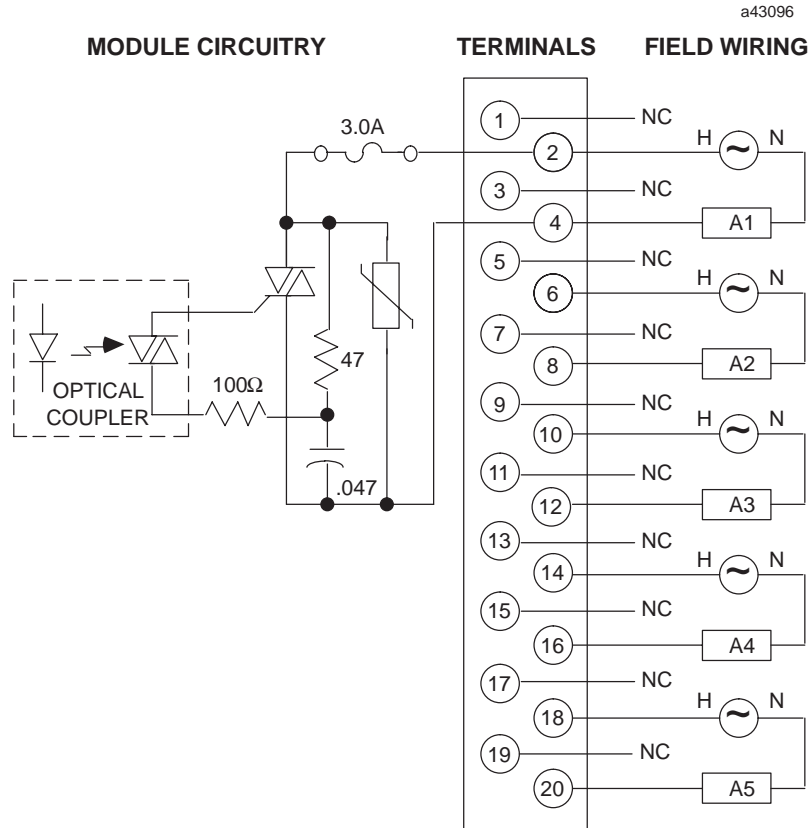

Figure 7-8. IC693MDL390 Output Module Field Wiring

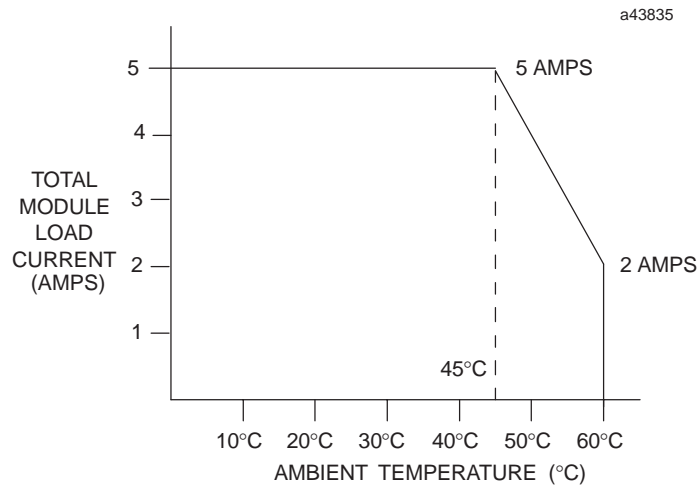

Figure 7-9. Load Current vs. Temperature for IC693MDL390