

125 Volt DC Positive/Negative Logic 1 Amp Output - 6 Point IC693MDL734

The *125 volt DC Positive/Negative Logic 1 Amp Output* module for the Series 90-30 Programmable Logic Controller provides 6 isolated output points. Each output has a separate common output terminal associated with it. This output module is designed to have either *positive logic* characteristics in that it sources current to the loads from the user common or positive power bus; or *negative logic* characteristics in that it sinks current from the loads to the user common or negative power bus. The output characteristics are compatible with a wide range of user-supplied load devices, such as: motor starters, solenoids, and indicators. Power to operate the field devices must be supplied by the user.

LED indicators which provide the ON/OFF status of each point are located at the top of the module. This LED block has two horizontal rows with eight green LEDs in each row. This module uses the first six LEDs in the top row, labeled A1 through 6 (points 1 through 6) for output status. An insert goes between the inside and outside surface of the hinged door. The surface towards the inside of the module (when the hinged door is closed) has circuit wiring information, and circuit identification information can be recorded on the outside surface. The outside left edge of the insert is color-coded red to indicate a high-voltage module. External fusing is recommended. Two amp loads can be driven by wiring and driving two outputs in parallel.

This module can be installed in any I/O slot of a 5 or 10-slot baseplate in a Series 90-30 PLC system.

Table 7-11. Specifications for IC693MDL734

Rated Voltage	125 volts DC
Output Voltage Range	+10.8 to +150 volts DC
Outputs per Module	6 (isolated)
Isolation	1500 volts between field side and logic side 500 volts between outputs
Output Current	1 amp maximum per point
Output Characteristics	
Inrush Current	15.89 amps for 10 ms
Output Voltage Drop	1 volt maximum
Off-state Leakage	1 mA maximum
On Response Time	7 ms maximum
Off Response Time	5 ms maximum
Power Consumption	90 mA (all outputs on) from 5 volt bus on backplane

Refer to Appendix B for product standards and general specifications.

IC693MDL734 Output Module Field Wiring Information

The following figure provides wiring information for connecting user supplied load devices and power source to the 125 volt DC positive/negative logic 1 amp output module.

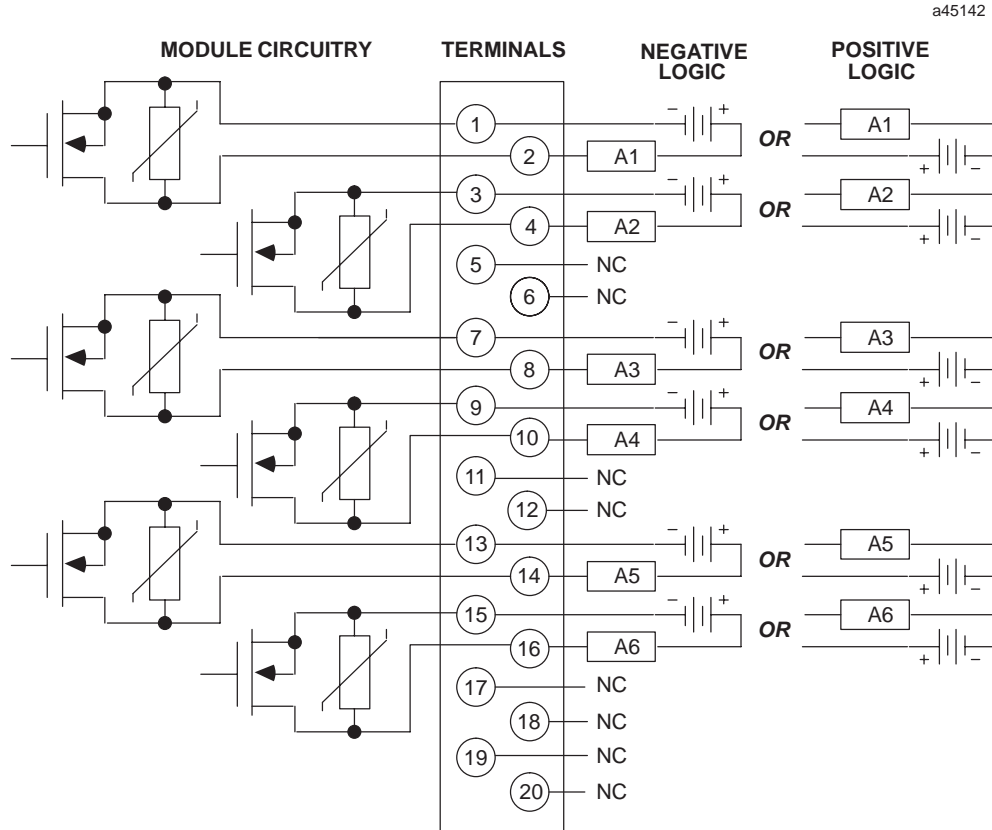

Figure 7-20. IC697MDL734 Output Module Field Wiring

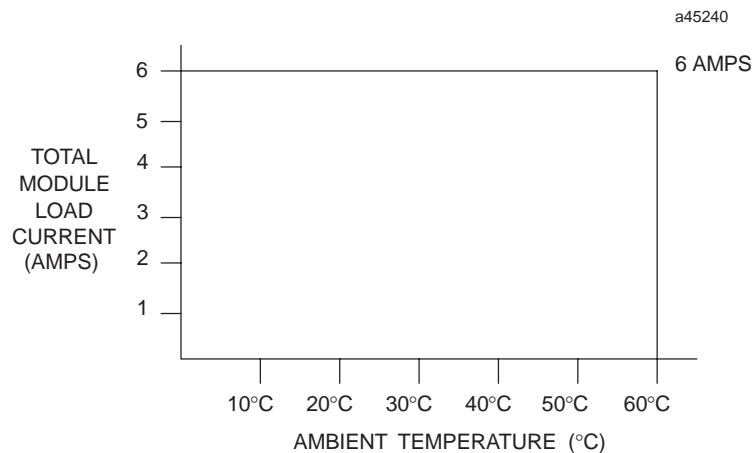

Figure 7-21. Load Current vs. Temperature for IC693MDL734