

## ORDERING INFORMATION

Order code: 10059  
 Description: BMH0175/120/208/240/C/CWI/H/K/  
 UPC: 69549100596



## SPECIFICATIONS

Ballast type: Magnetic metal halide  
 Ballast style: Core and coil  
 Circuit type: CWI  
 ANSI code: M57  
 Input voltage (V): 120/208/240  
 Input frequency (Hz): 60  
 Line volt regulation:  $\pm 10\%$   
 Line watt regulation:  $\pm 10\%$   
 Insulation class: H (180°)

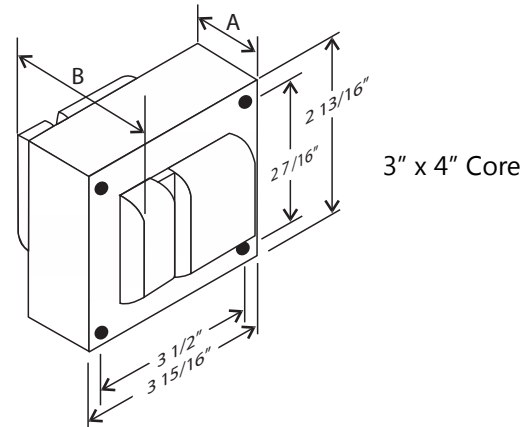

Input voltage (V)	Operating current (A)	Open circuit current (A)	Starting current (A)	Rated lamp watts (W)	Input watts (W)	OCV (V)	Dropout voltage (V)	UL 1029 code	Fuse rating (A)	Input current (A)	Power factor	Starting temperature
120	1.84	1.84	0.77	175	215	315	65	C	5	0.35 - 0.82	0.90	-20°F / -30°C
208	1.06	1.06	0.47	175	215	315	105	B	3	0.20 - 0.48	0.90	-20°F / -30°C
240	0.92	0.92	0.41	175	215	315	125	B	3	0.17 - 0.41	0.90	-20°F / -30°C

## HIGH POTENTIAL TEST (V)

1 minute:	2 000
2 seconds:	2 500
OCV test:	290 - 345
Short circuit:	1.50 - 1.90

## BALLAST DIMENSIONS

Dimension A:	2.80"
Dimension B:	4.20"
Lead Lengths:	12.00"
Weight (lbs):	9.50

## WIRING DIAGRAM

Ground ballast core

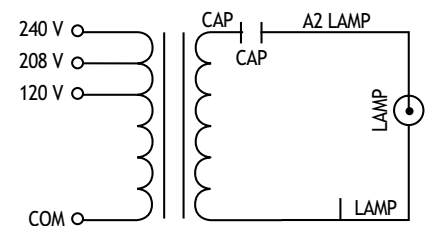

## BRACKET

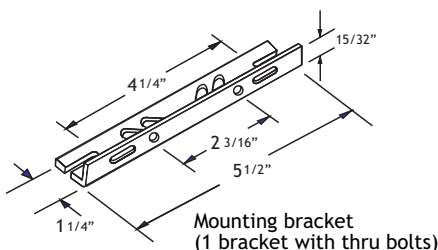

## CAPACITOR

