

24 Volt DC Input, Relay Output, 8 Inputs/8 Outputs IC693MDR390

The *24 volt DC Input/Relay Output* module for the Series 90-30 Programmable Logic Controller provides 8 input points with one common power input terminal, and 8 normally-open relay circuits in the same module. The input circuits are designed to have either positive or negative characteristics in that they sink or source current to/from the input devices to/from the user common and are arranged as one group of 8 inputs. The relay output circuits are arranged in two groups of four circuits each. Each group has a common power output terminal.

Input characteristics are compatible with a wide range of user-supplied devices, such as: pushbuttons, limit switches, and electronic proximity switches. Current through an input results in a logic 1 in the input status table (%I). Power to operate the field devices must be supplied by the user.

The normally-open relay circuits are used for controlling output loads provided by the user. The output switching capacity of each output is 2 amps. The relay outputs can control a wide range of user-supplied load devices, such as: motor starters, solenoids, and indicators. Power for the internal relay circuits is provided by the +24 volt DC bus on the backplane. The user must supply the AC or DC power to operate field devices. There are no fuses on this module.

LED indicators which provide the ON/OFF status of each point are located at the top of the module. The LEDs are arranged in two horizontal rows with eight green LEDs in each row. The top row is labeled A1 through 8 (input points 1 through 8) and the bottom row is labeled B1 through B8 (relay output points 1 through 8). An insert goes between the inside and outside surface of the hinged door. The surface towards the inside of the module (when the hinged door is closed) has circuit wiring information, and circuit identification information can be recorded on the outside surface. The top half of the outside left edge of the insert is color-coded blue to indicate low-voltage circuits and the bottom half of the outside left edge is color-coded red to indicate high-voltage circuits.

This module can be installed in any I/O slot of a 5 or 10-slot baseplate in a Series 90-30 PLC system.

Table 8-3. Specifications for IC693MDR390

| | |
|-----------------------------------|---------------------------------------------------------------------------------------------------|
| Inputs | |
| Rated Voltage | 24 volts DC |
| Input Voltage range | -30 to +32 volts DC |
| Inputs per Module | 8 (one group of eight inputs) |
| Isolation | 1500 volts RMS between field and logic side 500 volts RMS between inputs |
| Input Current | 7.5 mA (typical) at rated voltage |
| Input Characteristics | |
| On-State Voltage | 15 to 32 volts DC |
| Off-State Voltage | 0 to +5 volts DC |
| On-State Current | 4 mA (minimum) |
| Off-State Current | 1.5 mA (maximum) |
| On Response Time | 7 ms typical |
| Off Response Time | 7 ms typical |
| Outputs | |
| Rated Voltage | 24 VDC, 120/240 VAC |
| Operating Voltage | 5 to 30 volts DC 5 to 250 volts AC, 50/60 Hz |
| Outputs per Module | 8 (two groups of four outputs each) |
| Isolation | 1500 volts RMS between field and logic side 500 volts RMS between groups |
| Maximum Load † | 2 amps maximum per output 4 amps maximum per common |
| Minimum Load | 10 mA |
| Maximum Inrush | 5 amps |
| On Response Time | 15 ms maximum |
| Off Response Time | 15 ms maximum |
| Internal Power Consumption | 80 mA (all I/O on) from +5V backplane bus 70 mA (all outputs on) from relay +24V backplane bus |

† Maximum load current is dependent on operating voltage as shown in the following table.

Refer to Appendix B for product standards and general specifications.

Table 8-4. Load Current Limitations for IC693MDR390

| Operating Voltage | Maximum Current for Load Type | | Typical Operations (number of Operations) |
|--------------------------|-------------------------------|--------------------|-------------------------------------------|
| | Resistive | Lamp or Solenoid † | |
| 240 VAC, 120 VAC, 24 VDC | 2 amps | .6 amps | 200,000 |
| 240 VAC, 120 VAC, 24 VDC | 1 amp | .3 amps | 400,000 |
| 240 VAC, 120 VAC, 24 VDC | .5 amps | .1 amp | 800,000 |

† For inductive loads

Relay contact life, when switching inductive loads, will approach resistive load contact life if suppression circuits are used. The following figures are examples of typical suppression circuits for AC and DC loads. The 1A, 100V diode shown in the DC load typical suppression circuit is an industry standard 1N4934. The resistor and capacitor shown for AC load suppression are standard components, available from most electronics distributors.

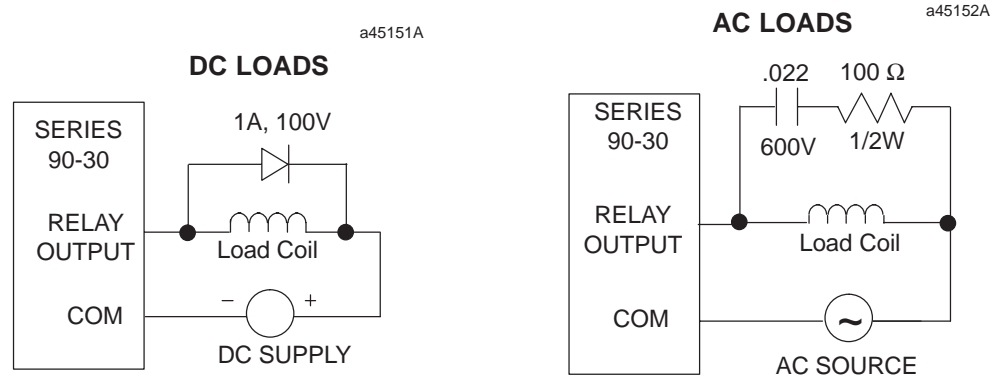

Field Wiring Information

The following figure provides wiring information for connecting user supplied input and load devices, and power source(s) to the 24 Volt Input/Relay Output module.

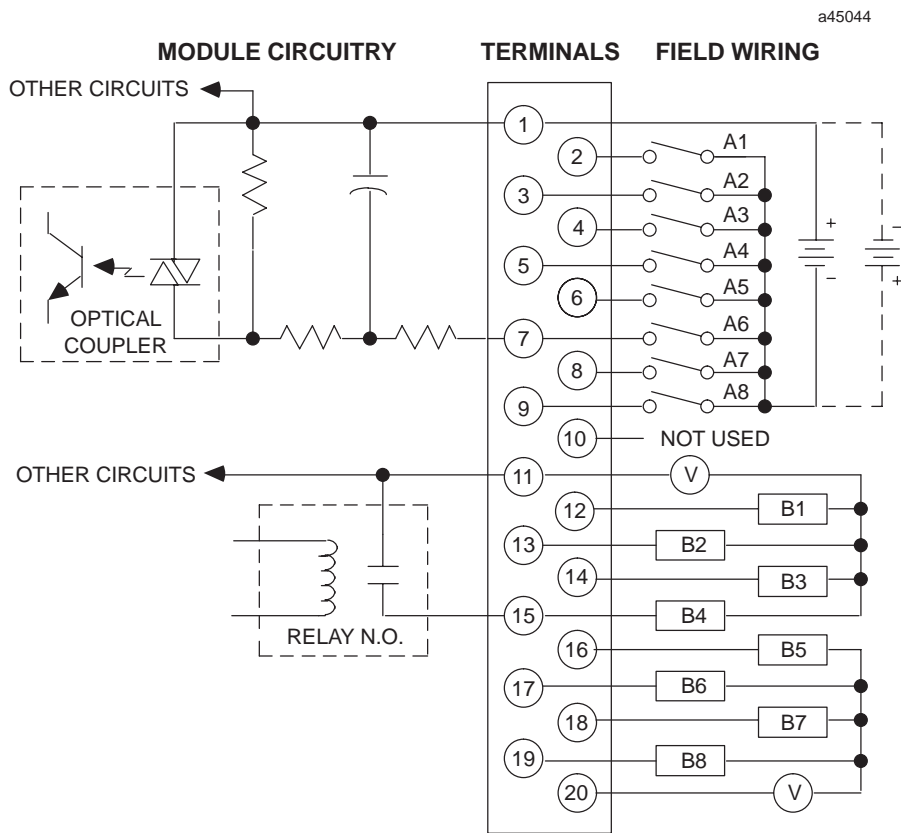

Figure 8-2. Field Wiring 24 VDC Input/Relay Output Module - IC693MDR390