

GFK-0532K
August 1997

Ethernet Controller

- Direct PLC attachment to IEEE 802.3 CSMA/CD LAN
- Standard 15-pin AUI port connection allows choice of 10Base5, 10Base2, 10BaseT, 10BaseF, or 10Broad36 medium with user-supplied 802.3-compatible transceiver
- For IC697 programmable controllers
- Occupies a single slot in PLC rack
- Software (separately licensed) is easily loaded or upgraded via RAM load
- Software is retained through power outages for a minimum of six months
- Alternative software packages provide:
 - TCP/IP communications
 - MMS/OSI communications
 - Full MS-DOS® or Windows® programming and configuration services
 - Comprehensive station management and diagnostic tools

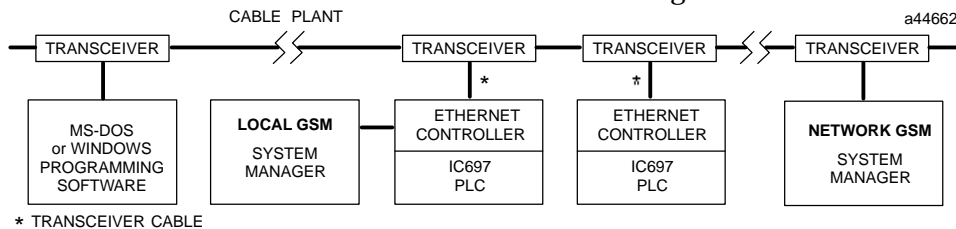

Figure 1. Ethernet Controller Connects the IC697 PLC to a 802.3 LAN

The Ethernet Controller is a member of the family of IC651 Factory LAN hardware and software products. The Factory LAN family of products provides high performance solutions for interconnecting automation controllers and for integrating them into multi-vendor networks.

The Ethernet Controller plugs into a single slot in an IC697 PLC rack and provides an 802.3-standard 15-pin D-connector for attachment of a user-supplied AUI (Attachment Unit Interface) or transceiver cable. The AUI cable connects to a user-supplied transceiver that is directly connected to the 10Mbps Ethernet network cable. The transceiver must be 802.3-compatible and must have the SQE option enabled.

Transceivers are commercially available to operate on a variety of 10Mbps media including thickwire coaxial cable (10Base5), ThinWire™ coaxial cable (10Base2), twisted pair (10BaseT), fiber optic (10BaseF), and broadband cable (10Broad36).

The Ethernet Controller is designed so the communications protocols which operate above the

Ethernet data link layer are implemented in software. This permits the user to choose between two* alternative communication protocols by downloading the Ethernet Controller with the applicable Communications Software:

- **TCP/IP-Ethernet Communications Software** - Communicate with host computers and/or MS-DOS or Windows Programmer using proprietary SRTP over a 4-layer TCP/IP (Internet) protocol stack; requires either a Local or Network Factory LAN System Manager (GSM) for configuration and downloading of Ethernet Controller software.
- **MMS-Ethernet Communications Software** - Communicate with host computers and/or MS-DOS or Windows Programmer using MMS (Manufacturing Message Specification - ISO 9506) on a 7-layer OSI protocol stack; requires GSM for configuration and downloading of Ethernet Controller software.

Figure 1 shows the general relationship between the Ethernet Controller, the local and network GSMs, and the MS-DOS or Windows Programming Software on Ethernet station.

* A third option, SRTP communications software (IC641SWP711) supports only communications with MS-DOS or Windows Programmers using SRTP over a 4-layer OSI protocol stack; this Ethernet Controller software does not require configuration and can be downloaded directly from the MS-DOS or Windows Programmer.

™ ThinWire is a trademark of Digital Equipment Corporation; ® IBM is a registered trademark of International Business Machines Corporation.
© MS-DOS, Windows, Windows 95, and Windows NT are registered trademarks of Microsoft Corporation.

GFK-0532K
August 1997

Ethernet Controller

Features of the Ethernet Controller

The Ethernet Controller is a single-slot module that is inserted directly into the IC697 CPU rack.

Connection to the Ethernet LAN is made via a transceiver cable to an external transceiver. The transceiver and cable are provided by the user. The transceiver is attached directly to the IEEE 802.3 network cable. The Ethernet Interface operates at 10 Mbps on the Ethernet LAN.

The Ethernet Controller uses three LEDs for indicating the status of the interface. A battery is provided to maintain the contents of Random Access Memory (RAM) over power outages.

The Ethernet Controller provides basic functions in firmware or Read Only Memory (ROM). This firmware includes self-test diagnostics and special software that allows you to configure and test your interface in the PLC and on the Ethernet LAN. It also allows you to load the communications software into RAM either from the GSM (serially or over the network), or from an MS-DOS or Windows OSI-Ethernet Programmer station.

The communications software is stored in RAM so you can upgrade communications software without replacing ROM chips. The battery maintains the contents of RAM over power outages.

“Soft Switches” are used to tailor the Ethernet Controller to your application. The MS-DOS or Windows Configuration Software package is used to configure the Ethernet Controller in the IC697 PLC, and to set the soft switches for the Ethernet Controller.

More detailed information about the Ethernet Controller, hardware installation, attachment to the Ethernet LAN, and Ethernet software follows this overview. For a complete description, refer to the User’s Manual that applies to the software you choose to run on it. These related publications are listed on page 8.

IEEE 802.3 Media

The Ethernet Controller can operate on any of the following media with the appropriate user-supplied transceiver cable and transceiver. IEEE 802.3 specifies the definitive requirements of each medium.

10Base5 Coax: 10Base5 uses a 0.4 inch diameter 50-ohm coaxial cable. The maximum length of a cable segment (single span of cable) is 500 meters. The distance between any two stations must be a multiple of 2.5 meters. A maximum of 100 stations is allowed on a thickwire Ethernet segment.

10Base2 Coax: 10Base2 uses a 0.2 inch diameter 50-ohm coaxial cable. The maximum length of a thinwire cable segment is 185 meters. A maximum of 30 stations is allowed on a thinwire Ethernet segment.

10BaseT: 10BaseT uses a twisted pair cable of up to 100 meters in length between each node and a hub or repeater. Typical hubs or repeaters support 6 to 12 nodes connected in a star wiring topology.

10BaseF: 10BaseF has two variations that both use the same type of fiber optic cable: 10BaseFP can support up to 33 nodes at distances of up to 500 meters from a passive star; 10BaseFL supports up to 2000 meters between a node and a repeater (a multi-port repeater would thus constitute a star). Additionally, 10BaseFB provides a means of interconnecting (only) repeaters by up to 2000 meters of (the same) fiber optic cable.

Note

Various Ethernet baseband media can be interconnected by appropriate repeaters. Capabilities and limitations are defined in IEEE 802.3 Chapter 13, “System Considerations for Multi-Segment Networks”.

10Broad36: 10Broad36 uses 75-ohm coaxial cable and CATV-like media components (taps, amplifiers, headend translators, etc.) to support hundreds of nodes at distances of up to 2800 meters. Broadband cannot be connected to baseband via repeaters. Broadband cable plant design and installation must be in accordance with IEEE 802.7 and requires special expertise. GE Fanuc recommends you contract professional specialists for these services. Consult your GE Fanuc sales representative or field service office for help in identifying local specialists.

Ethernet Controller

GFK-0532K
August 1997

Module Physical Description

Figure 2 shows the maintenance controls and indicators of the Ethernet Controller.

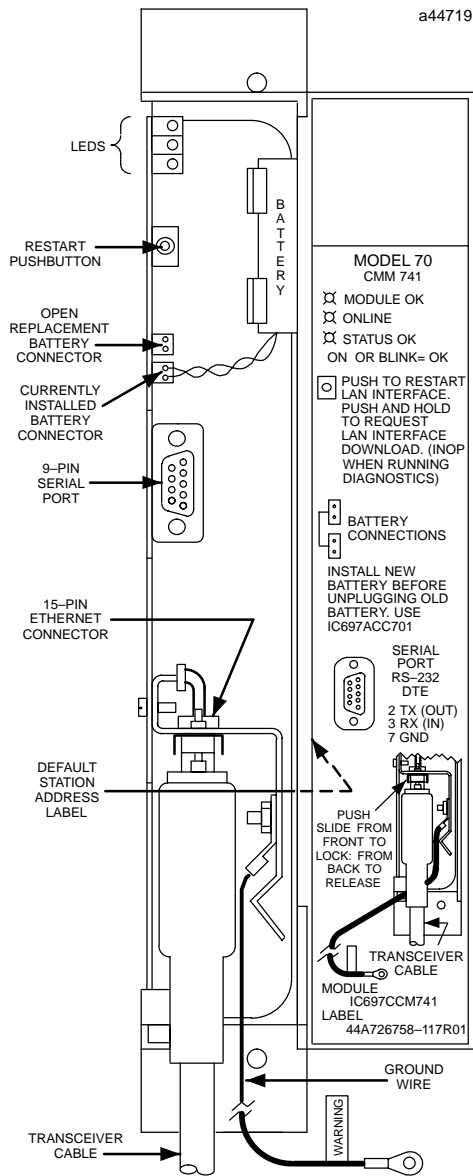

Figure 2. Ethernet Controller Board

User Maintenance Items

The Ethernet Controller has the following user-accessible elements:

- Three LEDs: located at the top front of the Ethernet Controller and are visible through a window in the front door.
- Default Station (MAC) Address Label: affixed on the outside of the plastic housing. This MAC station address is used for network communications, unless overridden by the user.
- Restart Button: located immediately below the LEDs.
- Battery and Battery Holder: located to the right of LEDs (between Restart button and serial port).
- Local Serial Port: 9-pin female connector for RS-232 Interface.
- AUI Port: 15-pin female connector with slide-lock for transceiver cable. Located beneath the local serial port.

Module Indicators

The Ethernet Controller board indicators consist of three Light Emitting Diodes (LEDs):

- MODULE OK
- ONLINE
- STATUS OK

See Figure 2 for LED location, and Table 1 for a description of these indicators.

Table 1. Ethernet Controller Indicators

Indicator	Status	Description
MODULE OK	ON	This LED is ON if the Ethernet Controller has passed diagnostics and its hardware is operating properly.
	OFF	It is OFF if the module fails a diagnostic test or if a fatal failure is detected while the board is running.
	BLINKING	This LED is blinking if the module is running diagnostics or is in Soft Switch entry state.
ONLINE	ON	This LED is ON when the Ethernet Controller is connected to and ready to communicate on the network.
	OFF	This LED is OFF when: <ul style="list-style-type: none"> - the station is not communicating in the network due to disconnection or a disruption of the cable. - the local station has malfunctioned. - the Ethernet Controller has been commanded not to enter the network or is in a state where network operation is inappropriate, such as Soft Switch Entry state or local loading.
	BLINKING	It is BLINKING when the module is transferring data on the network or loading over the network.
STATUS OK	ON	This LED is ON if the module is running without exception conditions.
	OFF	This LED is OFF if the module is running and detects an event that calls for supervisory attention. In this case you should connect the GSM and follow the instructions in Chapter 8 of the User's Manual to obtain further information.
	BLINKING	This LED is BLINKING if the module is loading or looking for a load source for the LAN Interfacesoftware.

Restart Button

The Restart button serves two functions: Restart, and Restart and Reload. The Restart button is inaccessible when the door to the Ethernet Controller is closed.

Restart: Pressing the Restart button (for less than 5 seconds) forces a restart of the Ethernet Controller. The power-up diagnostics run and the software on the module is restarted.

Restart and Reload: Pressing and holding the Restart button for 5 seconds or more requests a restart and reload of the Ethernet Controller. When the Restart button is pressed, all LEDs go out. After 5 seconds have elapsed, the STATUS OK LED will come ON to indicate that the Ethernet Controller will request a reload. Upon release of the button, the power-up diagnostics run and the Ethernet Controller requests a reload. See "Configuring and Loading the Ethernet Controller" for more information.

Note

Any data being transferred by the Ethernet Controller at the time of the Restart, or Restart and Reload, will be lost.

The Restart Button is not operable during the Ethernet Controller diagnostic phase. The Ethernet Controller is in diagnostic phase when the BOARD OK LED is BLINKING and the ONLINE and STATUS OK LEDs are OFF.

Battery

The battery and battery holder are located to the right of the LEDs. The battery connectors are located on the board between the Restart button and the 9-pin serial port connector.

When connected, the battery preserves the contents of RAM when there is no power to the board. The battery will maintain the RAM contents for a minimum of six months.

Ethernet Controller

GFK-0532K
August 1997

Local Serial Port

The 9-pin serial port (RS-232 interface) is used to connect locally to the Factory LAN System Manager (GSM) terminal. The communication software may be loaded through this port. The Ethernet Controller module is a Data Terminal Equipment (DTE) device. The pinouts of the port are shown in Table 2.

Table 2. RS-232 Port Pin Assignment

Pin	Signal	Description Number
2	TX	Transmit data (out)
3	RX	Receive data (in)
7	GND	Signal Ground

A cable is needed to connect the GSM to the Ethernet Controller. Figure 3 illustrates one type of GSM cable connection.

AUI Port

The 15-pin AUI port is located on the front bottom edge of the Ethernet controller board. This port connects the transceiver cable to the Ethernet Controller. The external 802.3 transceiver connects to the Ethernet network. Connector pinouts are shown in Table 3.

Caution

PLC power must be OFF when connecting or disconnecting the transceiver.

Note

Transceivers must be 802.3-compatible and must have the SQE option Enabled.

Table 3. Transceiver Port Pin Assignment

Pin	Signal	Description
1	GND	Signal Ground
2	CP+	Collision Presence +
3	TX+	Transmit +
4	GND	Signal Ground
5	RX+	Receive +
6	GND	Signal Ground
7	NC	Not Connected
8	GND	Signal Ground
9	CP-	Collision Presence -
10	TX-	Transmit -
11	GND	Signal Ground
12	RX-	Receive -
13	+12	+12 Volts
14	GND	Signal Ground
15	NC	Not Connected
Shell	PG	Protective Ground

Station Address Label

The Default Station (MAC) Address label lists the station address to be used by this module, unless a locally assigned address is set by the user via "Soft Switches". It is found on the right-hand outside of the plastic housing.

GFK-0532K
August 1997

Ethernet Controller

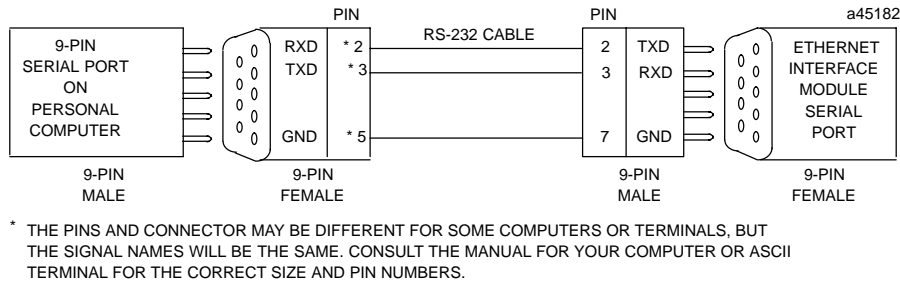

Figure 3. Cable to Connect the GSM to the Ethernet Interface

Installation

This section describes the physical installation of the Ethernet Controller into the IC697 PLC rack.

1. Read and record the 12-digit Default Station Address from the printed label on the Ethernet Controller.

A Station Configuration Data Form is provided in the User's Manual, for your convenience in recording the Station Configuration Information.

2. Be sure the IC697 PLC rack power is OFF.
3. Connect the Ethernet Controller battery:

Hold the module so the front cover is facing you with the hinge to the right. The tab on the battery cable should face to the right, away from the board surface.

Open the front cover of the Ethernet Controller module. The battery is mounted in the holder, but is not connected to the board. (See Figure 2.)

Connect the battery to either of the battery connectors on the card. Press down firmly to lock the battery connector in place.

4. Slide the Ethernet Controller into the slot for which it was configured in the system - normally the first available slot to the right of the CPU or Bus Transmitter Module (BTM). (See Figure 4. for the IC697 PLC rack layout)

Press firmly to lock the board in place, but do not force the board.

Note

The Ethernet Controller will not operate properly if there are empty slots to its left.

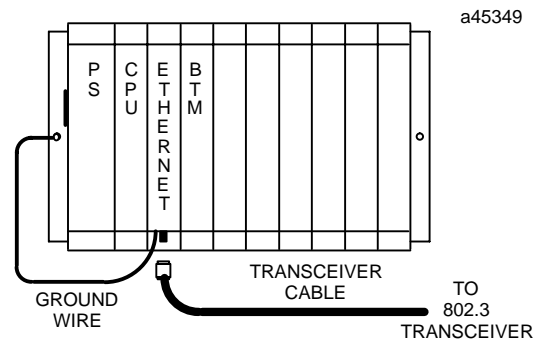

Figure 4. IC697 PLC Rack Layout

5. Connect the free end of the ground wire (18 inch long green wire attached to the Ethernet module) to the ground lug at the side of the IC697 PLC rack. (See Figure 4.)

Caution

The ground wire must be securely fastened to the chassis of the IC697 PLC rack and the rack must be properly grounded. Failure to do so may cause improper operation of the LAN.

Ethernet Controller

GFK-0532K
August 1997

- Connect the transceiver cable to the 15-pin AUI Port of the Ethernet Controller.

The other end of the transceiver cable should be connected to an external transceiver which is attached to the IEEE 802.3 network.

Warning

PLC power must be OFF when connecting or disconnecting the transceiver.

Note

Transceivers must be 802.3-compatible and must have the SQE option Enabled.

- Set the CPU Run/Stop switch to STOP.
- Power up the PLC rack.

Correct Results of Installation

During Power-Up: The MODULE OK LED on the front of the Ethernet Controller will BLINK during power-up diagnostics, and continue to BLINK while waiting for configuration data from the CPU.

After Power-Up: Once the Ethernet Controller has completed power-up diagnostics (about 15 seconds):

The MODULE OK LED will stop blinking, and should remain ON.

The ONLINE LED may be ON, OFF or BLINKING.

The STATUS OK LED will normally be BLINKING (unless software was previously loaded), indicating that the Ethernet Interface needs to be loaded.

If you get these indications, physical installation and power-up are complete. You may continue with Procedure 3 (or the next appropriate procedure) in Chapter 2 of the appropriate controller User's Manual.

Corrective Actions

MODULE OK OFF indicates a hardware fault, either in the Ethernet Controller or in the PLC, that prevents the Ethernet Controller from operating.

- Cycle power on the PLC to determine whether the fault is intermittent or a "hard" failure.

- If MODULE OK remains OFF, examine the PLC Fault Table for diagnostic information and take appropriate action. See the *IC697 Programmable Controller Installation and Operation Manual* for information on the PLC Fault Table.

For detailed troubleshooting information, refer to the applicable User's Manual.

Configuring and Loading the Ethernet Controller

As described earlier, the Ethernet Controller can be loaded with one of the alternative communications protocols. See Figure 5.

- TCP/IP Ethernet Communication Software.** If the Ethernet Controller must support TCP/IP communications to MS-DOS or Windows TCP/IP-Ethernet Programming software to other IC69* PLCs, CIM-PLICITY products, or Host Communications Drivers applications, you must create a configuration file on the Factory LAN System Manager (GSM) and download that file together with the TCP/IP communications software. The GSM software runs on a separate computer.
- MMS-Ethernet Communications Software.** If the Ethernet Controller must support MMS communications, you must create a configuration file on the Factory LAN System Manager (GSM) and download it together with the MMS communications software. The GSM is a separate computer running GSM software.

See the applicable user's manual for instructions on configuring and loading the Ethernet Controller. These operations are necessary before the LAN Interface can be used by your application.

Station Management Software

Operating a local area network entails certain LAN management activities. For the Factory LAN, this includes network performance measurement, fault diagnosis, configuration management, and downloading the appropriate configuration file and communication software to network nodes.

Many features to support these activities are built directly into the Ethernet Controller.

GFK-0532K
August 1997

Ethernet Controller

Nonetheless, certain occasional maintenance activities require that the user provide an external computer, such as a properly equipped IBM®-compatible personal computer.

The Ethernet Controller software includes the Factory LAN System Manager (GSM) to run on this external computer. The GSM is used to store on disk and to

download the communications software to the LAN Interface directly from the COM1 port on the GSM computer to the Ethernet Controller 9-pin serial port.

The System Manager (GSM) also supports node configuration and downloading across the LAN from a centralized location. A network GSM computer must include an appropriate Ethernet Interface.

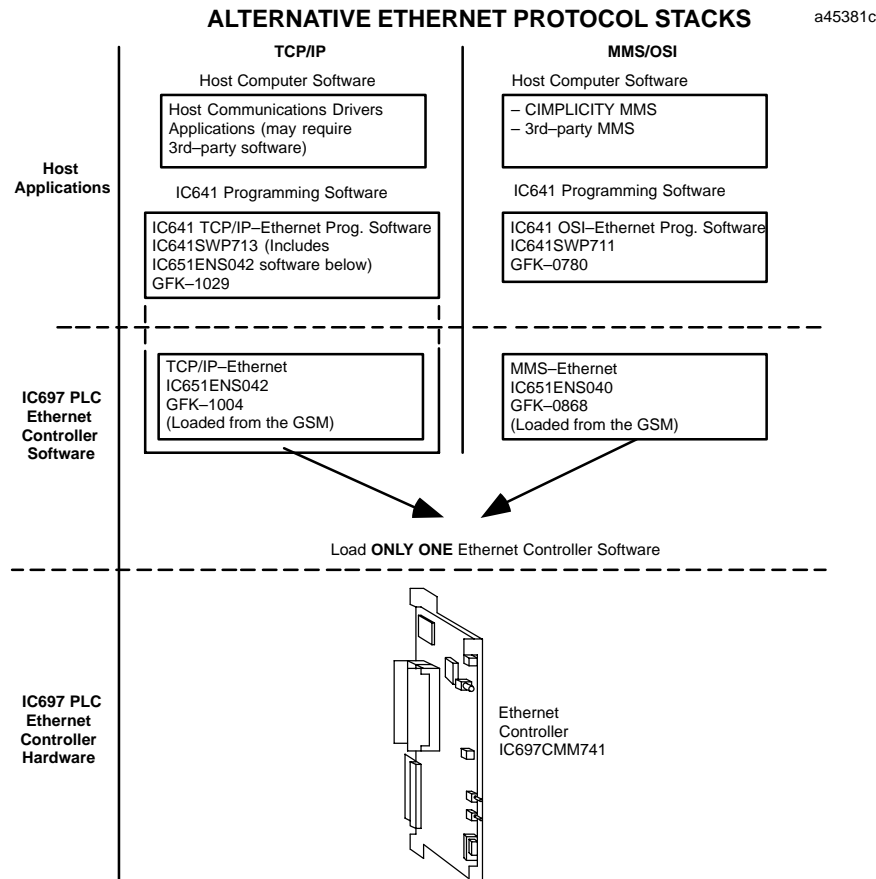

Figure 5. Alternative Ethernet Protocol Stacks for the IC697CMM741 Ethernet Controller

Related Publications (Factory LAN)

The following documents are related user documentation for the Factory LAN family of communication products.

- *TCP/IP-Ethernet Communications User's Manual*
- *MMS-Ethernet Communications User's Manual*
- *PLC Programmer TCP/IP-Ethernet User's Manual*
- *PLC Programmer-Ethernet User's Manual*
- *PLC Programming Software User's Manual*
- *Programmable Controller Reference Manual*
- *Programmable Controller Installation Manual*
- *Host Communications Toolkit C/C++ and Visual Basic User's Manual*
- *Host Communications Drivers for Microsoft Windows User's Manual*
- *TCP/IP Windows 95/Windows NT User's Manual Supplement*

Ethernet Controller

GFK-0532K
August 1997

Table 4. Module Specifications †

Power Consumption (Typical):	Power consumption for the Ethernet Controller includes external RS-232 loads and the external transceiver. The module is powered by the rack. The power supply must provide +12 Vdc. $\frac{+5 \text{ Vdc}}{1.00 \text{ A}} \quad \frac{+12 \text{ Vdc}}{0.5 \text{ A}}$
Memory Retention:	An on-board battery provides backup power (at least 6 months) when power is removed from the CPU rack containing the Ethernet Controller.
Physical Dimensions: Circuit Board: Mounting:	6.3 x 9.19 inches (160 x 233 mm). Occupies a single slot in an IC697 PLC rack. The module plugs into the IC697 CPU rack in the first available slot to the right of the CPU or BTM. (Bus Receiver Module if remote rack)
Connectors:	- LED Indicators: MODULE OK, ONLINE, STATUS OK - Restart pushbutton and Battery connectors - front edge of board behind the hinged door Serial and Transceiver Ports - Serial Port: 9-pin female, D-connector (to Local GSM) - Transceiver Port: 15-pin female, D-connector (to Ethernet transceiver cable and network)
Interface Specifications:	LAN (to Network GSM and/or IC641-Ethernet Programmer) IEEE 802.2 Logical Link Control Class I IEEE 802.3 CSMA/CD Medium Access Control 10Mbps Serial Port: RS-232 DTE, 9600 bps Transceiver Port: Ethernet, IEEE 802.3 CSMA/CD, Transceiver SQE must be Enabled.

† Refer to GFK-0867B, or later for product standards and general specifications. For installations requiring compliance to more stringent requirements (for example, FCC or European Union Directives), refer to *Installation Requirements for Conformance to Standards*.

Table 5. Ordering Instructions

Ethernet Controller	Ethernet Controller Module	IC697CMM741
TCP/IP Ethernet Controller Software	TCP/IP Software and Documentation for the PLC Ethernet Controller (Includes GSM).	IC651ENS042
TCP/IP Ethernet Programming Software and LAN Interface Software (MS-DOS version) (Windows version)	Software and Documentation for the IC641-TCP/IP Ethernet Programmer and Software and Documentation for the IC697 PLC (Includes IC651ENS042). TCP/IP Windows®95/Windows NT® MS-DOS® Box version of above.	IC641SWP713 IC641SWC716
MMS/OSI Ethernet Controller Software	MMS Software and Documentation for the PLC Ethernet Controller (Includes GSM).	IC651ENS040
OSI-Ethernet Programming Software	Software and Documentation for the IC641 OSI-Ethernet Programmer which includes SRTP-Ethernet software and documentation.	IC641SWP711

Note: For Conformal Coat option, or Low Temperature Testing option please consult the factory for price and availability.

Replacement Parts

PLC Power Supply	120/240 VAC or 125 VDC Input, 100 watt Power Supply 24 VDC Input, 90 watt Power Supply 48 VDC Input, 90 watt Power Supply (One of these Power Supplies is a prerequisite, since +5 Vdc and +12 Vdc are required by the Ethernet Controller Module)	IC697PWR711 IC697PWR724 IC697PWR748
Battery	Lithium Battery, 3V, to protect LAN Controller memory from power loss	IC697ACC701

