

Power Supplies

IC697PWR724/CE697PWR724

GFK-1047F
August 1997

24 VDC, 90W Power Supply Module

Features

- Operation from 24 VDC
- Three output voltages, 90 watts total
 - +5 VDC output up to 18 amps
 - +12 VDC output up to 1.5 amps
 - 12 VDC output up to 1 amp
- Slide-in rack mount construction
- Electronic short circuit overcurrent protection provided on 5 volt bus
- Two rack operation from a single power supply

Functions

The **90 Watt Power Supply Module** is a rack-mounted

unit that plugs directly into a 48-pin backplane-mounted connector in the leftmost slot in the rack. It provides +5 volt, +12 volt and -12 volt power, and logic level sequencing signals to the backplane.

This power supply can be used either in a single rack application, or can also be used to provide power to a second rack if the total load is within the supply rating. Interconnection to the second rack is through a pre-wired cable (IC697CBL700).

The power supply output will ride through a 10 msec total loss of input power at full load. Protection is provided for overcurrent and overvoltage fault conditions.

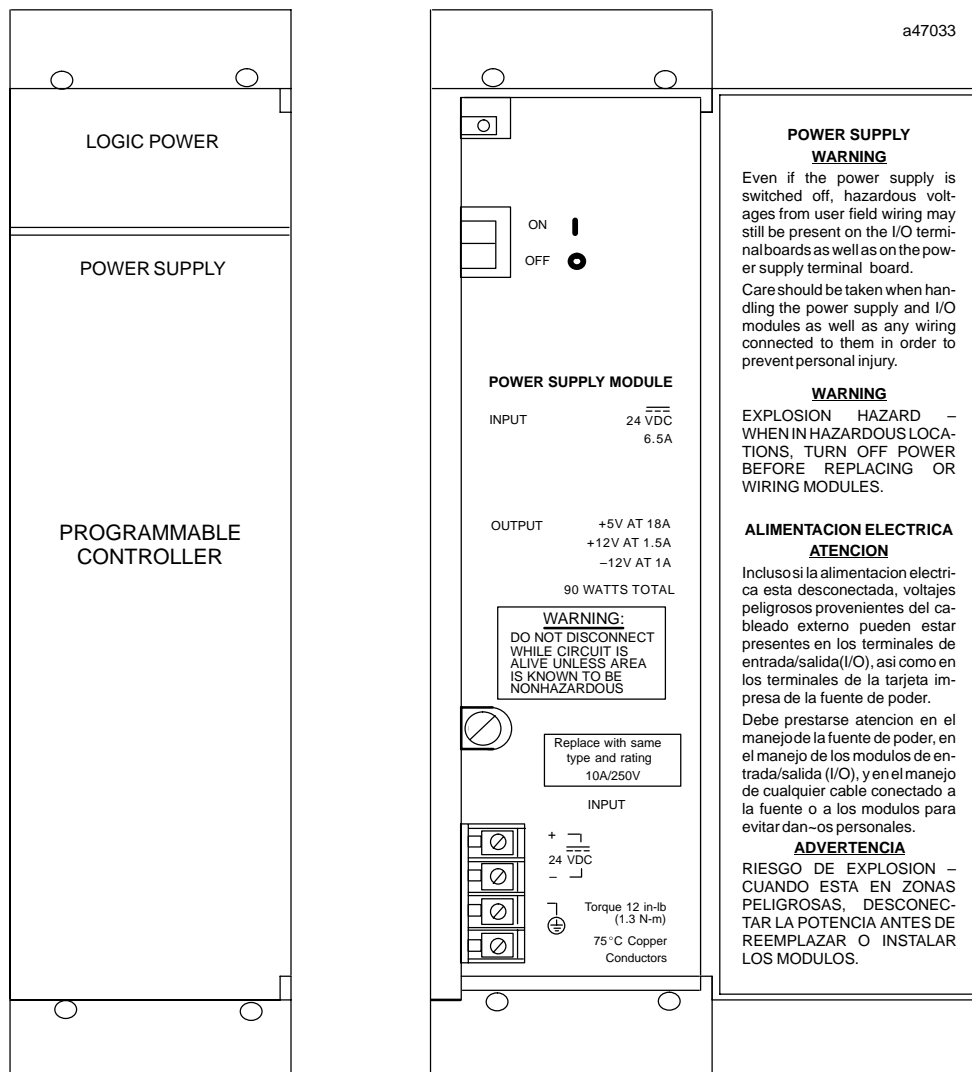

GFK-1047F
August 1997

24 VDC, 90W Power Supply Module

Operation of the Power Supply

This Power Supply Module operates from a 24 VDC nominal line. The power supply can accept an input voltage range of from 18 to 32 VDC.

Overvoltage Protection

The power supply includes an electronic overvoltage protection circuit. This circuit will clamp the output if the 5 V bus exceeds 6.7 volts. External overvoltage on the output will not cause the power supply fuse to open. However, if an internal fault in the power supply caused the overvoltage condition, the fuse may open. Replace this fuse with a 10 amp, 250 volt 5x20 mm fuse.

Overcurrent Protection

The power supply provides an electronic overcurrent limit for each of the three outputs (26 amps for +5 volts, 4 amps for +12 volts, and 2 amps for -12 volts (all maximum)). If the maximum current rating is exceeded, the output voltage will drop.

It will remain in that state until the load is either removed or reduced. A current overload (including a short circuit condition) will not cause the fuse to open.

Temperature Derating

For operation at ambient temperatures that exceed 50°C (122°F), maximum output power must be derated as shown in the derating curve.

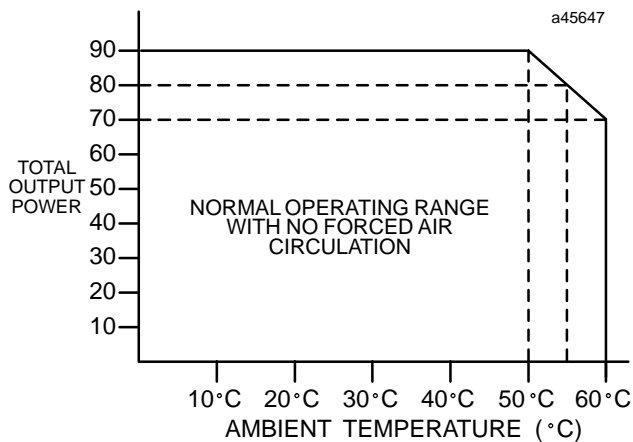

Figure 7. Output Power Derating Curve

Dual Rack Operation

A single power supply can provide power for two racks under the following conditions:

- Only 5 volt power is required in the second rack, and the total power required by both racks is within the capability of the supply.
- The current drawn by the second rack is less than 5.2 amperes.
- The two racks must be mounted in close proximity as limited by the available 3-foot connecting cable.

The connecting cable used for dual rack operation is listed in Table 2, *Ordering Information*. This cable carries the +5 volt power bus as well as the power sequencing signals. It uses a 9-pin D-type connector which connects directly to the backplane through an opening in the rack frame. Note that the cable carries power and power sequencing signals only. Inter-rack communication and bus interface modules must be provided separately. See the applicable *Programmable Controller Installation Manual* for application information.

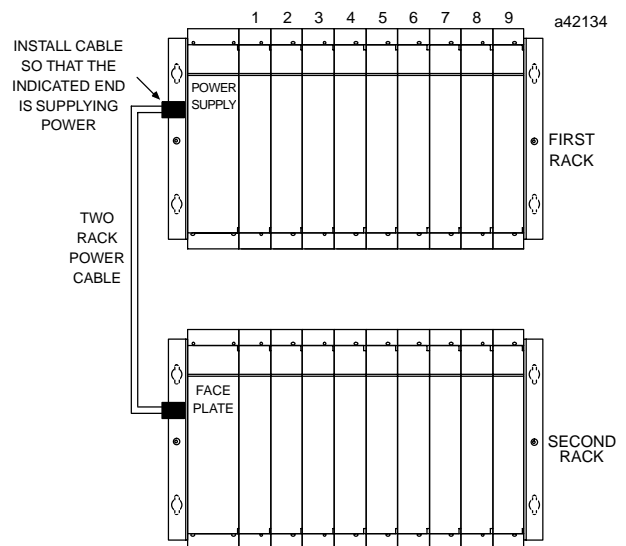

Figure 8. Dual Rack Configuration

Timing Diagram

The timing diagram below shows the relationship of the dc input power to the dc outputs and to the two system signals generated by the power supply: *ACFAIL* and *SYS-RESET*. The *5VSTBY* output may be used for user battery backup schemes as shown.

On application of power, the *ACFAIL* signal goes false soon after the 5 volt bus is within specification. The *sys-*

24 VDC, 90W Power Supply Module

GFK-1047F
August 1997

tem is held in the Reset state by SYSRESET for at least 200 milliseconds after 5 volt power is available (during this time, outputs are forced off).

If input power is interrupted, the 5 volt bus will remain within specifications for at least 10 ms. The system is then given an additional 5 milliseconds to complete an orderly shutdown before SYSRESET stops all processing.

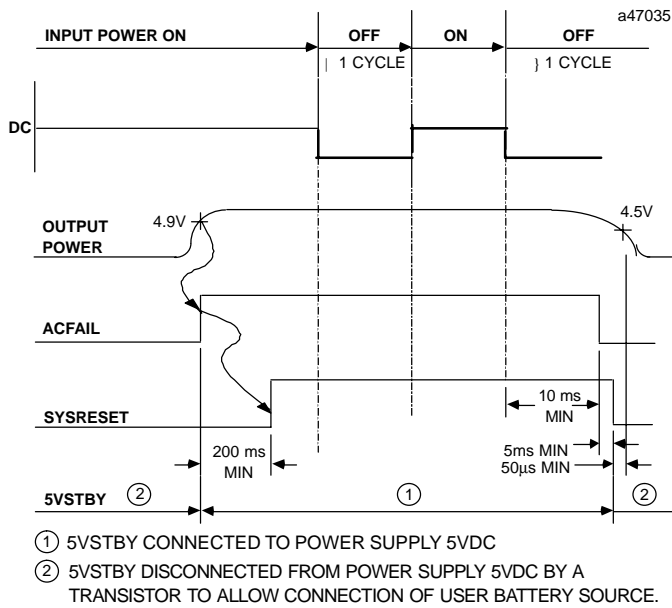

- ① 5VSTBY CONNECTED TO POWER SUPPLY 5VDC
- ② 5VSTBY DISCONNECTED FROM POWER SUPPLY 5VDC BY A TRANSISTOR TO ALLOW CONNECTION OF USER BATTERY SOURCE.

Figure 9. Timing Diagram for 24 VDC Power Supply

Note

Input power interruptions that exceed the power supply ride through time (10 milliseconds minimum) will result in a complete power down/power up cycle of ACFAIL and SYSRESET.

Inrush

When input voltage is initially applied, internal energy storage elements will draw a surge current from the 24 VDC input power source which can be in the range of 100 amps depending on the installation and power source impedance characteristics. Standard best practices should be used for installations where minimizing inrush current is a consideration. Typical best practices include providing local energy storage which can be either system batteries or capacitors at each power supply input, and minimizing resistance from the storage elements to prevent significant voltage drop during the initial energy transfer.

Note that this inrush *only occurs* during the initial application of input voltage to the power supply. Turning the power switch On and OFF *does not* disconnect pow-

er from internal energy storage elements, and therefore does not require inrush energy from the power source.

Mounting

The Power Supply is a plug-in module which is secured to the rack with four M 2.5 screws (included). Be certain that these screws are tightened both to secure the power supply to the rack, and to assure proper power supply-to-rack grounding.

Power Supply Door

The power supply door can be opened by grasping the upper left corner of the door with your right thumb or a fingernail and gently pulling the door towards you. Use care when opening the door since pulling from the bottom can cause the hinge or the door to break.

Input Voltage and Grounding

The power input terminal board provides two terminals for connecting 24 VDC power and an additional terminal for system and noise ground. Power input connections should be made with copper AWG #16 (1.33 mm²) through AWG #12 (3.31 mm²) wire rated for 75°C (167°F).

Each terminal can accept solid or stranded wires, but the wires into any given terminal should be the same type and size.

It is recommended that the GND terminal on the power supply be connected to the GND terminal on the rack and to earth using copper AWG #12 (3.3 mm²) wire rated for 75°C (167°F) and a ring terminal to ensure adequate grounding. Use of a nut and star washer for each wire on the GND lug is recommended.

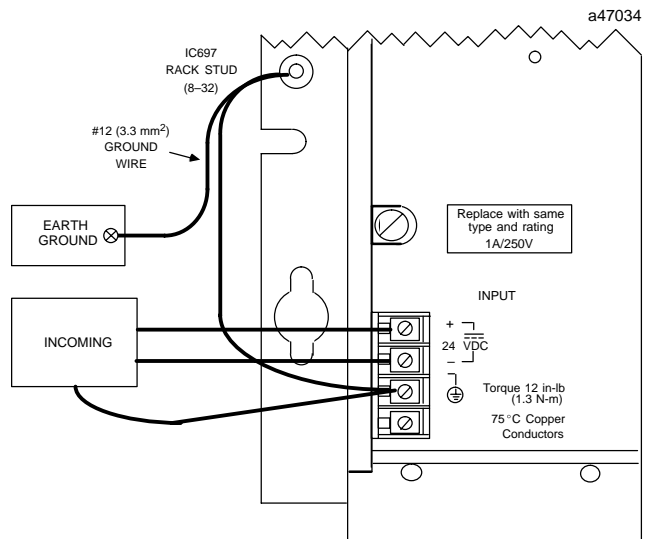

Figure 10. Input Wiring and Ground Connections

GFK-1047F
August 1997

24 VDC, 90W Power Supply Module

Warning

Because the power ON/OFF switch **does not** disconnect power from the internal storage elements, it is possible for the input terminals to discharge to user wiring when power is reapplied. To prevent this condition, **turn the power supply switch on after the removal of user input power** to discharge all stored energy through the supply.

System Noise Immunity

Two easy steps must be taken to properly ground the programmable controller system to reduce the possibility of errors due to electrical noise.

1. The GND terminal on the power supply must be connected to the GND terminal on either side of the rack using AWG #12 (3.3 mm²) wire. Use of a ring terminal and starwasher is recommended.
2. The GND terminal on the rack must be connected to a good earth ground.

Table 1. Specifications For IC697PWR724/CE697PWR724 †

Nominal Rated Voltage:	24 VDC
Input Voltage Range:	18 to 32 VDC
Input Power:	160 watts maximum @ full load
Input Inrush Energy:	22 joules maximum
Output Power:	90 watts maximum (total for all 3 outputs)
Output Voltage:	+5 VDC: 4.90 to 5.25 volts (5.07 volts nominal) +12 VDC: 11.75 to 12.6 volts -12 VDC: -12.6 to -11.75 volts
Protective Limits - Overvoltage Limit: Overcurrent Limit:	+5 VDC Output: 5.7 to 6.7 volts +5 VDC output: 26 amps, maximum +12 VDC output: 4 amps, maximum -12 VDC output: 2 amps, maximum
Ride Through Time:	10 milliseconds minimum @20 VDC
VME	System designed to support the VME standard C.1

† Refer to data sheet GFK-0867B, or later for product standards and general specifications.

Table 2. Ordering Information

Description	Catalog Number
Power Supply, 24 Volts DC, 90 Watts	IC697PWR724 CE697PWR724
Power Supply Extension Cable (includes cable and faceplate for vacant power supply slot in second rack).	IC697CBL700

Note: For Low Temperature Testing option please consult the factory for price and availability.

24 VDC, 90W Power Supply Module

GFK-1047F
August 1997

The following markings are required to appear in the applicable Programmable Controller Installation

Manual and data sheet for Class I Div 2 Hazardous Locations.

1. EQUIPMENT LABELED WITH REFERENCE TO CLASS I, GROUPS A, B, C, and D, DIV. 2 HAZARDOUS LOCATIONS IS SUITABLE FOR USE IN CLASS I, DIVISION 2, GROUPS A, B, C, D OR NON-HAZARDOUS LOCATIONS ONLY.
2. WARNING - EXPLOSION HAZARD - SUBSTITUTION OF COMPONENTS MAY IMPAIR SUITABILITY FOR CLASS I, DIVISION 2.
3. WARNING - EXPLOSION HAZARD - DO NOT DISCONNECT EQUIPMENT UNLESS POWER HAS BEEN SWITCHED OFF OR THE AREA IS KNOWN TO BE NON-HAZARDOUS.

