



MR16/GU10/PAR16

7MR16/F25 3000 DIM AF2 10/1

Philips MR16 Dimmable LED Lamps provide ambient level light to illuminate hard to maintain applications. Increased transformer compatibility allows for operation on a wider range of transformers. Available in dimmable and non-dimmable versions, these lamps are ideal for track and open recessed fixtures in retail, hospitality and residential spaces.

Product data

General Information	
Cap-Base	GU5.3 [GU5.3]
Nominal Lifetime (Nom)	40000 h
Switching Cycle	50000X
Technical Type	7-35W
Light Technical	
Color Code	930 [CCT of 3000K]
Beam Angle (Nom)	24 °
Light Distribution	Medium beam 24°
Luminous Flux (Nom)	440 lm
Luminous Intensity (Nom)	2200 cd
Color Designation	White (WH)
Rated Beam Angle	24 °
Correlated Color Temperature (Nom)	3000 K
Luminous Efficacy (rated) (Nom)	58.57 lm/W
Color Consistency	<6
Color Rendering Index (Nom)	90
LLMF At End Of Nominal Lifetime (Nom)	70 %
Luminous Flux in 90° Cone (Rated)	410 lm

Operating and Electrical	
Power (Rated) (Nom)	7 W
Lamp Current (Nom)	720 mA
Starting Time (Nom)	0.5 s
Warm Up Time to 60% Light (Nom)	1 s
Power Factor (Nom)	0.7
Voltage (Nom)	12 V

Temperature	
T-Case Maximum (Nom)	92 °C

Controls and Dimming	
Dimmable	Yes

Approval and Application	
Energy Efficiency Label (EEL)	A
Energy Saving Product	Yes
Suitable For Accent Lighting	Yes
Energy Consumption kWh/1000 h	8 kWh

Product Data	
Order product name	7MR16/F25 3000 DIM AF2 10/1

MR16/GU10/PAR16

EAN/UPC - Product	046677457457
Order code	929001152904
Numerator - Quantity Per Pack	1
Numerator - Packs per outer box	10

Material Nr. (12NC)	929001152904
Net Weight (Piece)	0.045 kg

Dimensional drawing

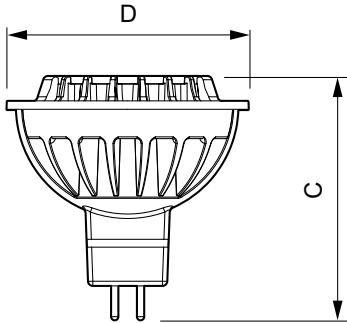

LED D 7-35W 830 MR16 24D

Product	D	C
7MR16/F25 3000 DIM AF2 10/1	51 mm	51 mm

Photometric data

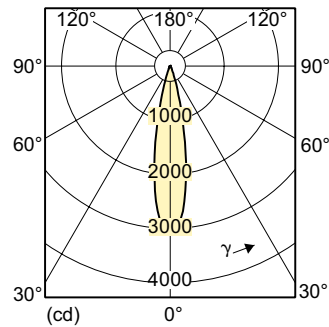
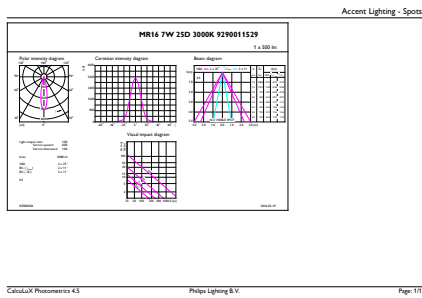

LEDspot 7-50W MR16 GU5.3 3000K 440lm 24D

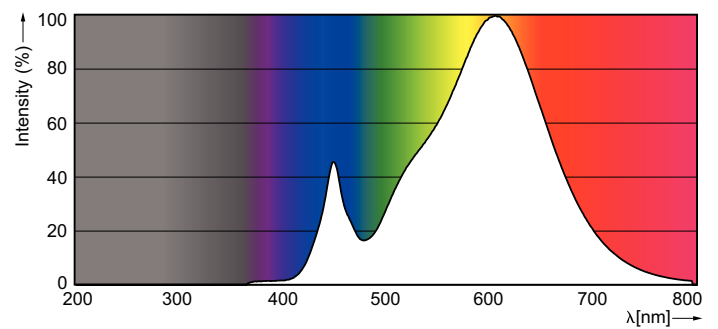

8-50 W GU5.3 /830 MR16

