

**Specification Submittal Data / Panasonic Ventilation Fan**

**Description**

Ventilating fan shall be low noise remote mount type rated for continuous run. Fan shall be ENERGY STAR® rated and certified by the Home Ventilating Institute (HVI). Evaluated by Underwriters Laboratories and conform to both UL and cUL safety standards.

**Motor/Blower:**

- Four-pole totally enclosed condenser motor rated for continuous run.
- Power rating shall be 120 volts and 60 Hz.
- Fan shall be UL listed for tub/shower enclosure when used with a GFCI branch circuit wiring.
- Motor equipped with thermal-cutoff fuse.

**Housing:**

- Galvanized steel body for long-life.
- Insulated housing to prevent condensation and noise.
- Tapered duct adapter for easy connection.

**Easy Installation:**

- 5 positions installation.
- Joist, truss and suspension brackets included.

**Warranty:**

- 3-Year limited warranty.

**Architectural Specifications:**

Ventilating fan shall be remote mount, Energy Star rated, with no less than 340 CFM as certified by the HVI at .2 static pressure in inches water gauge. Power consumption shall be no greater than 98.2 Watts, and energy efficiency rating shall be no less than 3.5 CFM/Watt. The motor shall be totally enclosed, four pole condenser type engineered to run continuously. Power rating shall be 120v/60Hz. Housing shall be insulated to reduce condensation. Duct diameter shall be no less than 6". Fan shall be UL and cUL listed for tub/shower enclosure when used with GFCI branch circuit wiring. Brackets shall be provided for joist, truss or suspension installations. ASHRAE 62.2, LEED, ENERGY STAR IAP, CA Title 24, EarthCraft and WA Ventilation Code complaint.

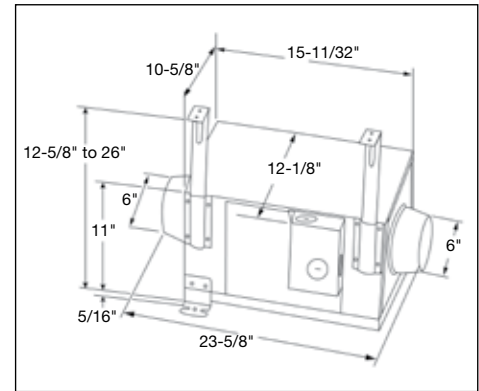

FV-30NLF1

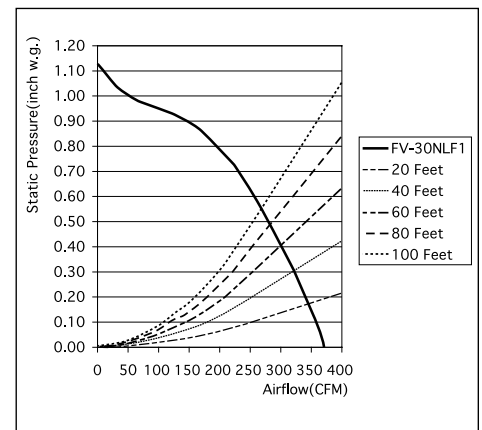

Specifications: <b>WhisperLine</b> FV-30NLF1					
Static Pressure in inches w.g.	Air Volume (CFM)	Power Consumption (Watts)	Energy Efficiency (CFM / Watts)	Speed (RPM)	Current (amps)
0.2	340	98.2	3.5	1337	0.86
0.3	322	96.4			
0.4	302	94.9			

For complete Installation Instructions visit [www.panasonic.com/building](http://www.panasonic.com/building)

Model	Quantity	Comments	Project:
			Location:
			Architect:
			Engineer:
			Contractor:
			Submitted by:
			Date:

**Panasonic Home and Environment Company**  
Division of Panasonic Corporation of North America  
One Panasonic Way  
Secaucus, NJ 07094  
[www.panasonic.com/building](http://www.panasonic.com/building)

