



SIEMENS

Ingenuity for life



VersiCharge™ electric vehicle charging station post

- **Mount VersiCharge Universal, SG, SG OCPP or Utility**

Enjoy the freedom of installing any VersiCharge Universal, SG, SG OCPP and Utility EV charger wherever it is needed with a freestanding post.

Choose from the single post (part number US2:VCPOSTGRY) or dual post (part number US2:VCPOSTGRY2)

Install a single post for one VersiCharge Universal, SG, SG OCPP, or Utility or plan for future needs with a dual post; mount one VersiCharge now and, whenever it is required, add another.

- **Secure your charger**

The convenient loop design is included in the single post design, so you can easily add a lock of choice to secure the charger to the post. In the dual

post design, chargers can be locked through 10-32 tamper-resistant screws.

- **PV fade resistant and rust resistant finish**

The VersiCharge Universal, SG, SG OCPP or Utility post is ready to withstand tough weather conditions like PV fading and saltwater spray. The aluminum construction and stainless steel hardware will not rust, and the durable powder coating keeps the post looking like new for many years. It is built to the standard of all other Siemens NEMA 4R enclosures, and can be located either indoors or outdoors.

- **Multiple wiring options**

The power supply can be run under ground up through the bottom of all the charger post options.

Single Post: Power to the charger will be wired at the back of the unit to the power supply coming in through the middle of the post.

Dual post: Wires to supply power to the charger(s) may be brought in through the side of the post by drilling a hole for the conduit to connect to the main power supply which is routed through the inside of the post.

- **Cable management system**

Single Post design – an arm located on either side of the post holds the cable when not in use. (Note: The cable retraction system is not available for the Single Post design.)

- **Cable retraction system**

Dual Post design – The cable retraction system conveniently stows the cable out of the way for a clean look and design. Each charger will require a separate cable retraction system.

NOTE: This simple weight and pulley system doesn't require any maintenance and can be added at any time.

Catalog number: US2:VCPOSTGRY and US2:VCPOSTGRY2 are compatible with US2:VC30GRYU, US2:VCSG30GRYUW and US2:VCSG30GCPUW

Part number	Description
US2:VCPOSTGRY	Basic VersiCharge Universal, SG, SG OCPP, or Utility Single Post with fixed arm hangers (Cable retraction system not available.)
US2:VCPOSTGRY2	VersiCharge Universal, SG, SG OCPP, or Utility Dual Post (Can support one or two chargers and two cable retraction systems.)
US2:VCCMSSP	VersiCharge Universal, SG, SG OCPP, or Utility Cable Retraction System, 20ft cable

NOTE: Please order the US2:VCCMSSP in conjunction with US2:VCPOSTGRY2 to get the complete assembly for pedestal and retractor.



Basic Single Post with Cable Management System



Dimensions: Basic Single Post Part No.: US2:VCPOSTGRY

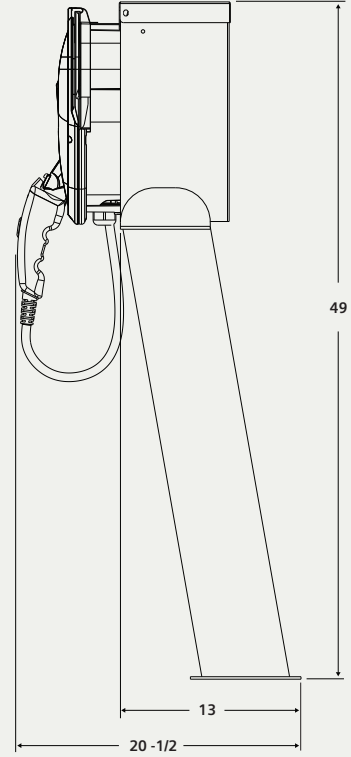
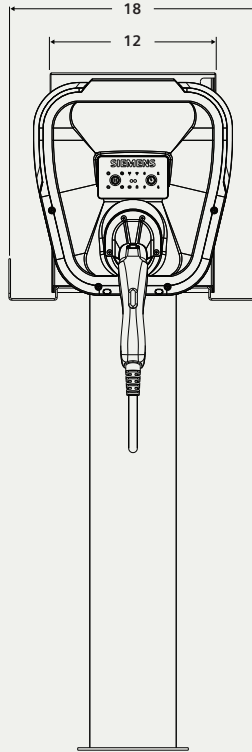

Dual Post



Dual Post with one cable retraction system



Dual Post with two cable retraction systems



Dimensions: Dual Post – No cable retraction system Part No.: US2:VCPOSTGRY2

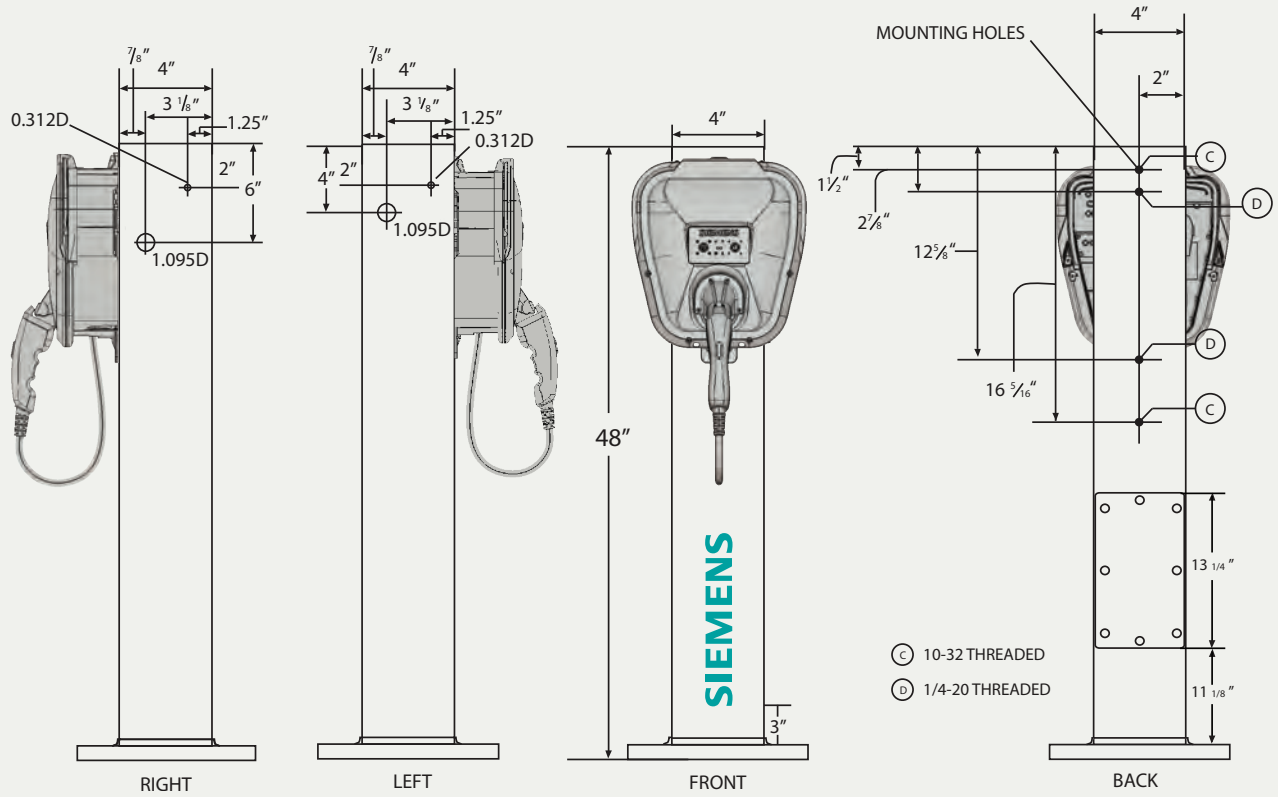

Dimensions: Dual Post with single cable retraction system Part No.: US2:VCPOSTGRY2 and US2:VCCMSSP-Qty. 1

