

AUTOMATIC SNOW AND ICE MELTING CONTROLLER

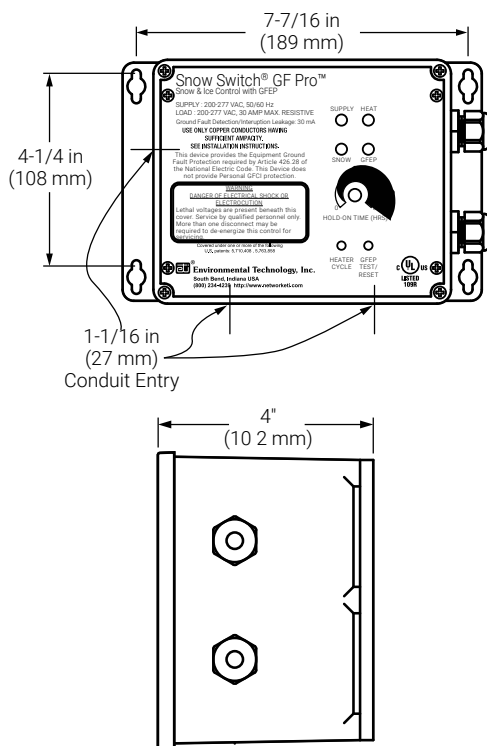
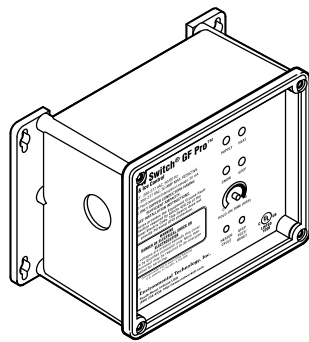

PRODUCT OVERVIEW

The ETI® GF Pro is an automatic snow and ice melting controller for pavement, sidewalks, loading docks, roofs, gutters and downspouts in commercial and residential environments.

The GF Pro interfaces with up to two sensors, (any combination of CIT-1, GIT-1 or SIT-6E) to meet site requirements. The controller features automatic and manual-override operator controls. The adjustable Hold-On timer continues heater operation up to 8 hours after the sensors stop detecting snow or ice to ensure the rest of the slab has completely dried. The Heater Cycle control button allows manual initiation or cancellation of a heating cycle. The optional RCU-4 remote control unit can be located for convenient monitoring and control. These flexible control options provide complete snow melting and water evaporation at a low operating cost.

The GF Pro also features a built-in 30 mA, self-testing Ground-Fault Equipment Protection (GFEP) capability, digitally filtered to minimize false tripping. A ground-fault alarm must be manually reset using the Test/Reset switch before heater operation can continue.

The GF Pro is housed in an environmentally-sheltered Type 4X enclosure and weighs only 3 pounds. The GF Pro is a snow and ice controller for medium-sized applications whose features and power requirements do not require an APS or EUR Series control panel. For complete information describing application, installation, and features, please contact your nVent representative or visit nVent.com.

GENERAL

Area of use

Nonhazardous locations

Approvals

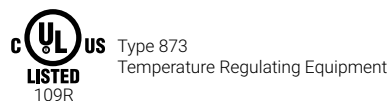

Also evaluated by Underwriters Laboratories Inc in accordance with UL 1053 Ground-Fault Sensing and Relaying Equipment



ENCLOSURE

Protection	Type 4X
Dimensions	5 1/2" (L) x 8 1/8" (W) x 4 3/8" (H) 140 mm (L) x 207 mm (W) x 112 mm (H)
Material	Polycarbonate
Cover attachment	Polycarbonate cover, machine screws
Weight	3 pounds (not including sensors)
Mounting	Wall mount
Entries	2 x 3/4" entries (right) for NEC Class 2 connections 3 x 1-1/16" entries (bottom and left) for supply and load power

CONTROL

Supply voltage	100-277 Vac; 50/60 Hz
Load	30 A maximum resistive
Heater Hold-On timer	0 – 8 hrs; actuated by snow stopping or toggle switch
System test	Switch toggles heater contact on and off. If temperature exceeds optional high limit thermistor (45°F), heater shuts off to reduce costs and prevent damage

FRONT PANEL INTERFACE

Status indicators	SUPPLY (green): Power on HEAT (yellow): Heating cycle in progress SNOW (yellow): Sensor(s) detect snow GFEP (red): Ground-Fault condition GFEP (red, flashing): Failed GFEP (red, rapid flashing): GFEP test in progress
-------------------	---

GROUND-FAULT EQUIPMENT PROTECTION (GFEP)

Set point	30 mA
Automatic self-test	GFEP verified before contactors operate; GFEP runs on start-up and every 24 hours
Manual Test/Reset	Test/Reset switch on front panel

ENVIRONMENTAL

Operating temperature	-31°F to 130°F (-35°C to 55°C)
Storage temperature	-67°F to 167°F (-55°C to 75°C)

ORDERING INFORMATION

Catalog number	Part number	Description
GF Pro*	P000001509	Automatic Snow and Ice Melting Controller
CIT-1*	512289-000	Aerial Snow Sensor
GIT-1*	126795-000	Gutter Ice Sensor
SIT-6E*	P000000112	Pavement Mounted Snow and Ice Sensor

* The GF Pro does not come with any sensors. Sensors must be ordered separately.

North America

Tel +1.800.545.6258
Fax +1.800.527.5703
info@nvent.com



nVent.com

Our powerful portfolio of brands:

CADDY ERICO HOFFMAN RAYCHEM SCHROFF TRACER