

# PLUGMOLD PLUS™ NM2000

## INSTALLATION INSTRUCTIONS

Installation Instruction No.: 41080R4 – Updated June 2003

Wiremold Electrical Systems conform to and should be installed and properly grounded in compliance with requirements of the current National Electrical Code, Canadian Electrical Code or codes administered by local authorities.

All electrical products may represent possible shock or fire hazard if improperly installed or used. Wiremold electrical products are UL Listed to U.S. and Canadian safety standards, made for interior use only, and should be installed in conformance with current local and/or the National Electrical Code.

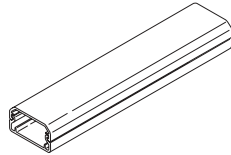

	Wire Size THHN/THWN	No. of Wires O.D.	@ 40% Fill
Power Wiring Without Devices	10 AWG	0.153	15
	12 AWG	0.122	31
	14 AWG	0.105	45
Power Wiring With Plugmold Devices	10 AWG	0.153	—
	12 AWG	0.122	8*
	14 AWG	0.105	8*

\*Includes the four conductors of the wiring harness.

**1** Lay out Raceway path. Determine feed method and location from figures A, B, and C below.

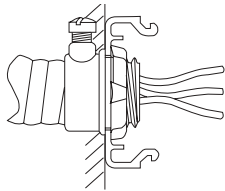

Fig. A\* – Back Feed

\* This method is not recommended if splice area is less than 4". See Figure B or C for feeding this condition.

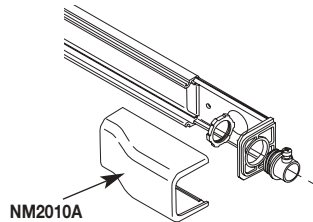

Fig. B – End Feed

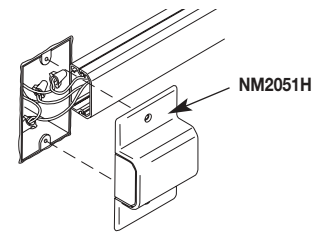
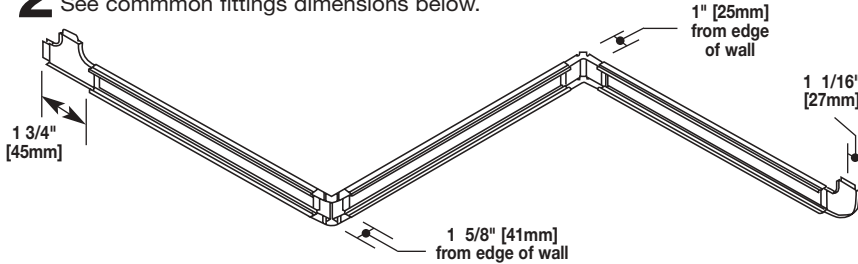
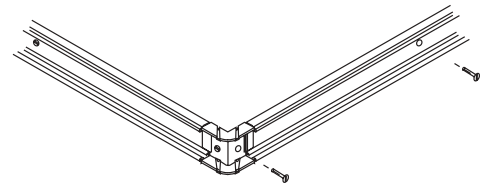

Fig. C – Feed from Existing Wall Box

**2** Measure and cut raceway base and cover. See common fittings dimensions below.



**3** Install raceway and fittings bases using No. 8 flathead screws.



**Wiring Method – Refer to Instructions (A thru E) according to your application.**

### A Field Wired Raceway – NM2000 Series:

**A1** Install wire in raceway and install wire clips as needed.

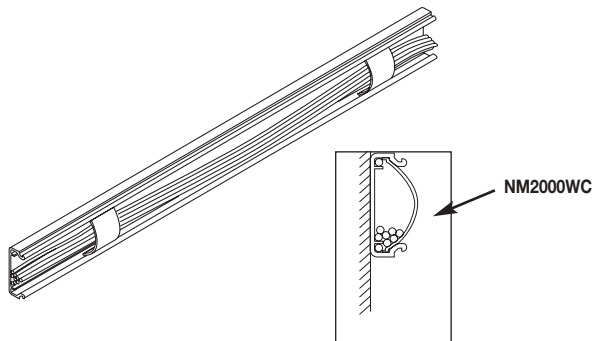

**A2** Install blank end fittings with No. 8 flathead screws where needed. Slide raceway cover into end fitting.

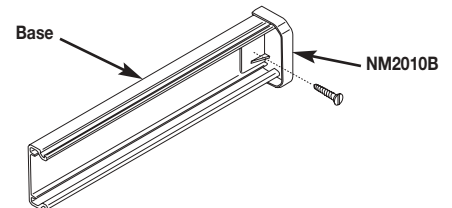

**A3** Snap on raceway and fitting covers.

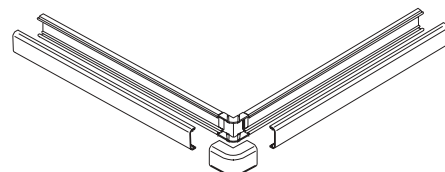

## B Wired Cover Sections:

**B1** Connect receptacle harness to feedpoint using approved methods.

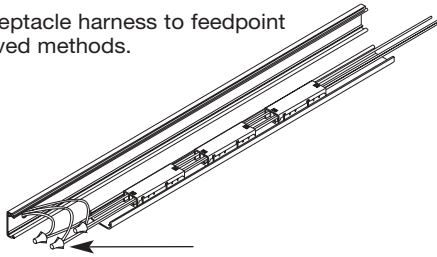

**B2** Snap cover/harness assembly onto base and snap on any fitting covers.

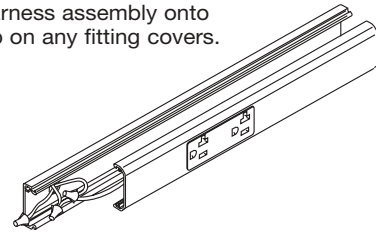

**B3** For additional circuits, use bypass area shown below.

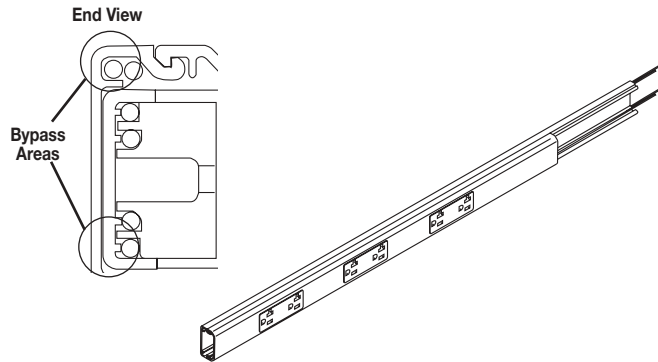

## C Wired Cover Sections with Receptacle Surge Protection – NM20SGB Series:

Install wired cover system as above.

**C1** To remove, back out screw and unplug. To replace, push in plug and install screw.

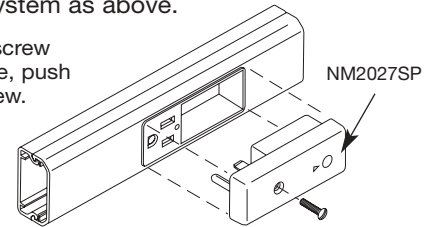

**NOTE:** This device features an internal protection that will disconnect the surge protective component at the end of its life but will maintain power to the load – now unprotected. If this situation is undesirable for the application, follow manufacturer's instructions for replacing this device.

## D Snapicoil – NM2000SC Series:

**D1** Lay out Snapicoil harness so that receptacles are not located over feed point or at corners. Connect harness to feed point.

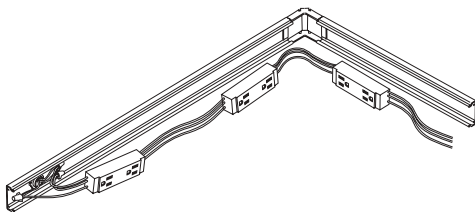

**D2** Snap receptacles into NM2000 cover.

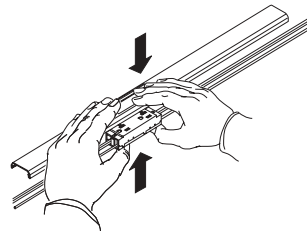

**D3** Snap wired cover section onto base and snap on any fitting covers.

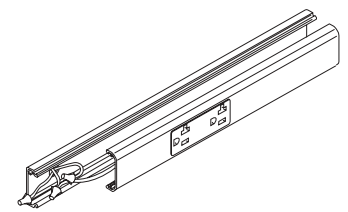

## E Relocatable Power Tap – NM20C:

**E1** Install mounting clip using flat head screws.

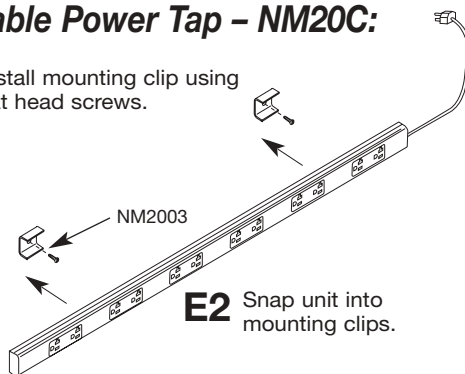

**E2** Snap unit into mounting clips.

**E3** Plug cordset into wall outlet.



The Wiremold Company

U.S. and International:

60 Woodlawn Street • West Hartford, CT 06110

1-800-621-0049 • FAX 860-232-2062 • Outside U.S. 860-233-6251

Canada:

850 Gartshore Street • Fergus, Ontario N1M 2W8

1-800-741-7957 • FAX 519-843-5980

