

## DSL Filter Board

### APPLICATION

The DSL Filter Board, designed to fit into any Leviton Structured Media™ enclosure, separates the DSL portion of an incoming telephone signal prior to distribution throughout the home, eliminating the need for a micro-filter system at each wallplate. Available as an expansion for Leviton's Pre-Configured Structured Cabling Panels, or as a stand-alone module on an ABS plastic bracket.

### STANDARDS COMPLIANCE

Meets or exceeds all applicable standards: UL recognized components.

### PHYSICAL SPECIFICATIONS

Dimensions: DSL Filter Board:  
5.750"H x 1.750"W x 0.702"D

Bracket:  
6.561"H x 2.132"W x 2.202"D

Material: DSL Filter Board:  
Printed Circuit Board

Bracket:  
ABS plastic, white

### DESIGN CONSIDERATIONS

- Filters DSL from the telephone line before the line is distributed throughout the home, acting as a robust whole house filter.
- Fits easily into any Leviton Structured Media enclosure.
- Quick-Snap feature for easy expansion board installation.
- Available as a stand-alone module on an ABS plastic bracket.
- Dedicated jack for modem.
- Designed to filter any telephone line (line 1, 2, 3 or 4) coming into the home.

See ELECTRONIC FILES for CAD files (.DXF, .DWG, MS-DOS.EPS) on disk



PN# 47616-DSB, DSL Filter Module shown.

DSL Filter Board

### WARRANTY INFORMATION

- Two-year limited product warranty.

For ELECTRONIC Typical Specs see (.TXT) file on disk.

### TYPICAL SPECIFICATIONS

The DSL Filter Board shall meet or exceed all applicable standards as UL recognized components. The board shall be of printed circuit board construction and the bracket of white, ABS plastic. It shall filter DSL from any telephone line (line 1, 2, 3 or 4), as a whole house application. It shall feature a dedicated modem jack and be available as an expansion board, or as a stand-alone module. The manufacturer shall provide a two-year limited product warranty.



For Technical Support Call 1-425-485-4288; in USA call 1-800-824-3005  
Spec sheets and updates are also available at [www.levitonvoicedata.com](http://www.levitonvoicedata.com).

2222 - 222nd St. SE • Bothell, WA 98021 USA  
Tel: 1-800-722-2082 / 1-425-485-4288 • Fax: 1-425-483-5270 • Int'l Fax: 1-425-485-9170 • GSA Schedule Available



# DSL Filter Board

## Part Numbers

**47616-DSF**  
**47616-DSB**

### DIMENSIONAL LINE ART

See ELECTRONIC FILES for CAD images  
 (.DXF, .DWG, MS-DOS.EPS)

PN# 47616-DSB

PN# 47616-DSF

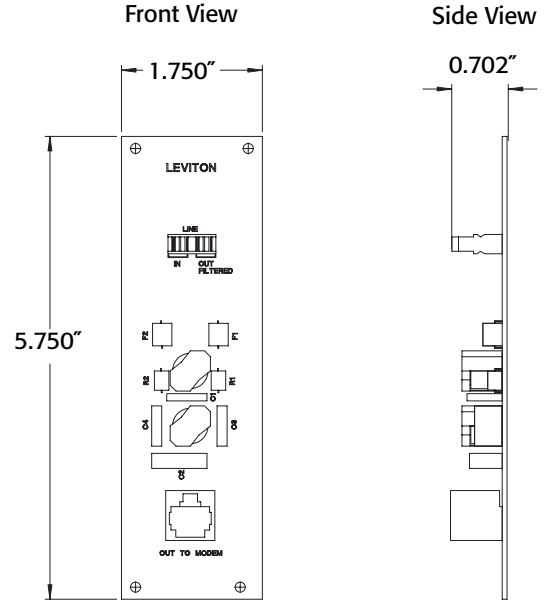
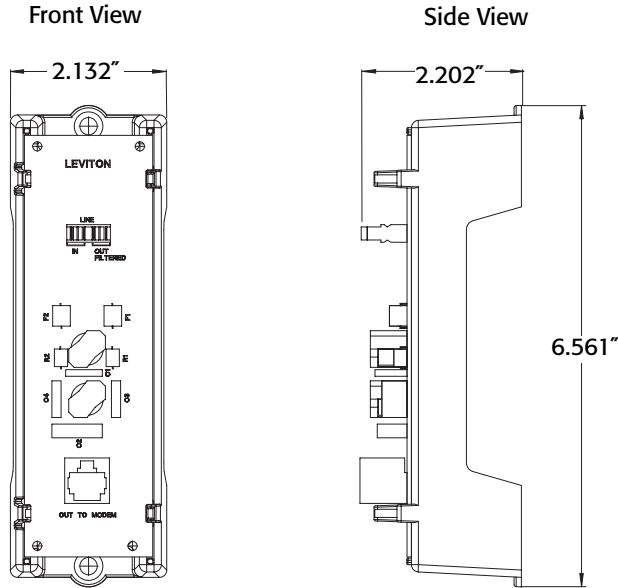

### PART NUMBER

Description	Part Number
DSL Filter Board	47616-DSF
DSL Filter Module (with bracket)	47616-DSB



For Technical Support Call 1-425-485-4288; in USA call 1-800-824-3005.  
 Spec sheets and updates are also available at [www.levitonvoicedata.com](http://www.levitonvoicedata.com).



2222 - 222nd St. SE • Bothell, WA 98021 USA  
 Tel: 1-800-722-2082 / 1-425-485-4288 • Fax: 1-425-483-5270 • Int'l Fax: 1-425-485-9170 • GSA Schedule Available