

THIS COPY IS PROVIDED ON A RESTRICTED BASIS AND IS NOT TO BE USED IN ANY WAY DETRIMENTAL TO THE INTERESTS OF PANDUIT CORP.

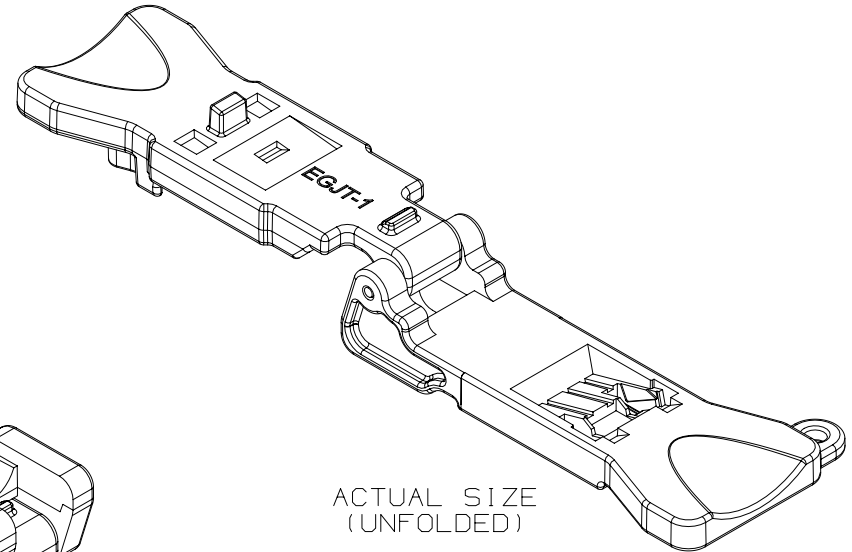
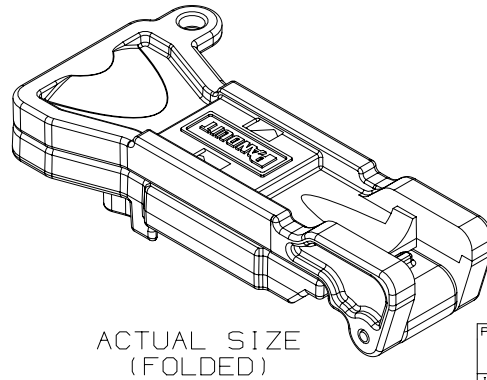
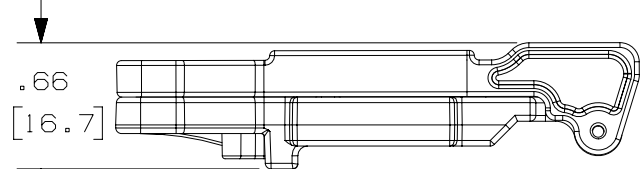
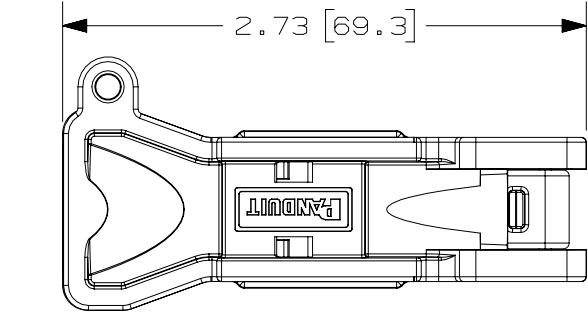
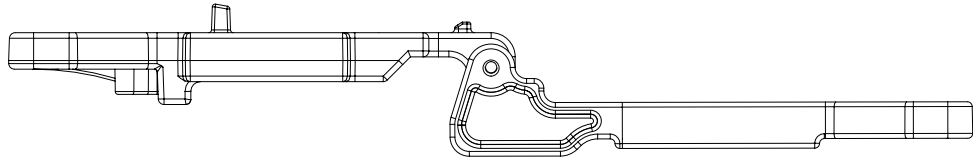
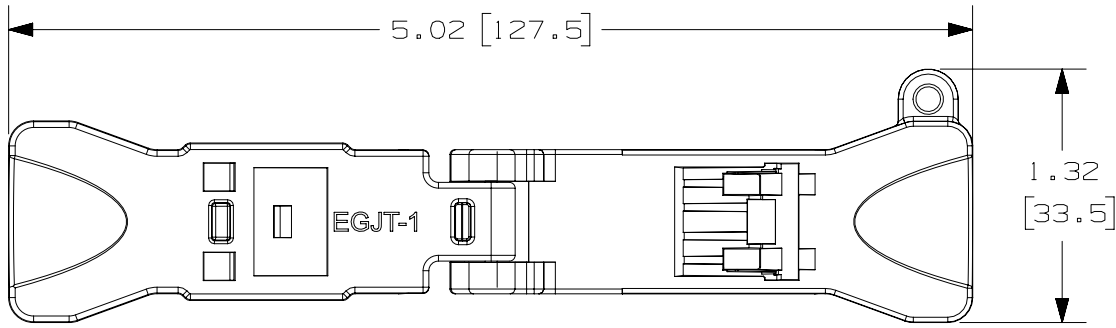

PANDUIT P/N	WEIGHT
EGJT-1	.29 LB/10 PCS (131.6 g/10 PCS)

- NOTES:
1. TERMINATION TOOL FOR TG JACK MODULES AND FIELD TERMINABLE PLUG FP6X88MTG
 2. TERMINATES ALL CJ**TG** JACK MODULES AND FP6X88MTG
 3. DIMENSIONS IN BRACKETS ARE IN METRIC.
 4. MATERIAL: GLASS-FILLED NYLON

PART NUMBER	EGJT-1	PRODUCT SPEC/PKG SPEC	N/A	
I.T. NUMBER	N/A	WORK INSTRUCTION	N/A	
TITLE				
TG TERMINATION TOOL				
CUSTOMER DRAWING				
ITEM REVISION NAME		00068SKC/04		
DATASET FILE NAME		00068SKC_DC02/04A		
UNLESS OTHERWISE SPECIFIED, DIMENSIONAL TOLERANCES ARE: IN [mm]		PANDUIT REVIEW DRAWING NUMBERS: 00068SKA-01, 00068SKB-01, 00068SKC-01, 02436-04 DRAWING NUMBER: 00068SKC-02		
.x ± .1 [2.54]				.xxx ± .005 [.127]
.xx ± .01 [.25]				ANGLES ± 5 °
THIRD ANGLE PROJECTION		DRAWING NUMBER: 00068SKC-02		
DRAWN BY	DATE	CHK	SCALE	
BJN	12-15-16	DCS	FULL	
SHT 1 OF 1		SIZE A		

REV	DATE	BY	CHK	APR	DESCRIPTION	ECN
3	6-12-17	BJN	DCS	TMBA	RELEASED TO PRODUCTION UPDATED ASSY MODEL TO REV 04 (SADDLE REDESIGNED)	00068SKC-02
2	2-24-17	BJN	DCS	TMBA	REV 2 NOT RELEASED TO PRODUCTION B. UPDATED ASSY MODEL TO REV 03, TEXT DEPTH OF P/N CHGD	00068SKC-02
1	2-1-17	BJN	DCS	TMBA	REV 1 NOT RELEASED TO PRODUCTION A. UPDATED MODEL (SADDLE) TO REV 02	00068SKC-02
R	12-15-16	BJN	DCS	TMBA	REV R NOT RELEASED TO PRODUCTION	00068SKC-02

D10100DA/14