

THIS COPY IS PROVIDED ON A RESTRICTED BASIS AND IS NOT TO BE USED IN ANY WAY DETRIMENTAL TO THE INTERESTS OF PANDUIT CORP.

TWIST TIE

NOTES:

- **1. SEE CURRENT CATALOG FOR VARIOUS APPLICATIONS AND TO INDICATE COLOR AND OR PACKAGE QUANTITY.
- 2. SEE CATALOG FOR A COMPLETE LIST OF PARTS APPLICABLE FOR USE WITH THIS PART.
- 3. TERMINATED WITH (8 POSITION) MODULAR PLUGS AT BOTH ENDS PER T568B.
- 4. CONSTRUCTED WITH STRANDED CAT6 UTP 24AWG LSZH PATCH CABLE
- 5. MATERIALS:
 PLUG: POLYCARBONATE
 BOOT: CLEAR PVC
- 6. NOMINAL CABLE JACKET DIAMETER IS 0.235 IN (5.97MM)

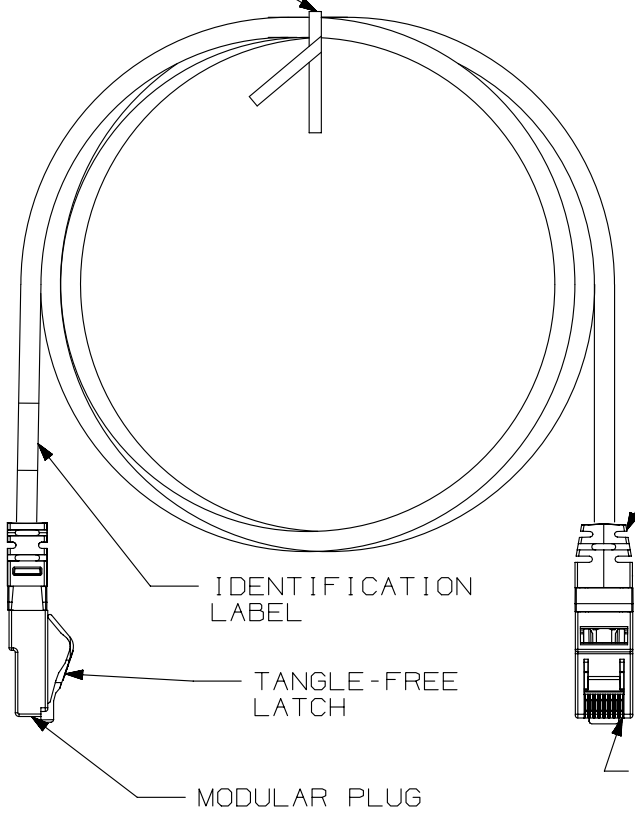

STRAIN RELIEF BOOT

T568B WIRING SCHEME

PLUG POSITION:

- 1
- 2
- 3
- 4
- 5
- 6
- 7
- 8

CABLE WIRE:
 WHITE/ORANGE
 ORANGE
 WHITE/GREEN
 BLUE
 WHITE/BLUE
 GREEN
 WHITE/BROWN
 BROWN

PLUG POSITION 1

CABLE COLORS **	= COLOR
OFF WHITE	--
BLACK	BL
BLUE	BU
RED	RD
YELLOW	YL
GREEN	GR
ORANGE	OR
VIOLET	VL
GRAY	GY
WHITE	WH

SEE SHEET 2 FOR
 PATCH CORD LENGTHS
 AND PART NUMBERS

PART NUMBER		UTPSPLXX**Y	
TITLE			
TX6 PLUS UTP PATCH CORDS (LSZH)			
CUSTOMER DRAWING			
ITEM REVISION NAME		M02479MK/00	
DATASET FILE NAME		M02479MK_DC324/00D	
UNLESS OTHERWISE SPECIFIED, DIMENSIONAL TOLERANCES ARE: IN [mm]		MATERIAL:	
.x ±		.xxx ± .010 [.3]	
.xx ± .03 [.8]		ANGLES ±	
DRAWING NUMBER:		02479-324	
THIRD ANGLE PROJECTION			
DRAWN BY	DATE	CHK	SCALE
NER	3-23-06	WJC	NONE
SHT 1 OF 2			SIZE
			A

REV	DATE	BY	CHK	APR	DESCRIPTION	ECN
3	4-3-14	BJN	JSP	EJH	REVISED & REDRAWN PREVIOUS REVS REMVD FOR CLARITY	02479-324

D10100DA/14

2

1

2

1

THIS COPY IS PROVIDED ON A RESTRICTED BASIS AND IS NOT TO BE USED IN ANY WAY DETRIMENTAL TO THE INTERESTS OF PANDUIT CORP.

TX6 PLUS UTP LSZH PATCH CORDS

PANDUIT PART NUMBER	MIN. CABLE LENGTH
UTPSPL0.5M**Y	0.5 METER
UTPSPL1M**Y	1 METER
UTPSPL1.5M**Y	1.5 METER
UTPSPL2M**Y	2 METERS
UTPSPL2.5M**Y	2.5 METERS
UTPSPL3M**Y	3 METERS
UTPSPL4M**Y	4 METERS
UTPSPL5M**Y	5 METERS
UTPSPL6M**Y	6 METERS
UTPSPL7M**Y	7 METERS
UTPSPL8M**Y	8 METERS
UTPSPL9M**Y	9 METERS
UTPSPL10M**Y	10 METERS
UTPSPL15M**Y	15 METERS
UTPSPL20M**Y	20 METERS
UTPSPL25M**Y	25 METERS
UTPSPL30M**Y	30 METERS
UTPSPL35M**Y	35 METERS
UTPSPL40M**Y	40 METERS

PART NUMBER		UTPSPLXX**Y	
TITLE			
TX6 PLUS UTP PATCH CORDS (LSZH)			
CUSTOMER DRAWING			
ITEM REVISION NAME		M02479MK/00	
DATASET FILE NAME		M02479MK_DC324/00D	
UNLESS OTHERWISE SPECIFIED, DIMENSIONAL TOLERANCES ARE: IN [mm]		PANDUIT	
.x ± .xxx ± .010 [.3] .xx ± .03 [.8]			
ANGLES ±		DRAWING NUMBER:	
THIRD ANGLE PROJECTION		02479-324	
DRAWN BY	DATE	CHK	SCALE
NER	3-23-06	WJC	NONE
SHT 2 OF 2			SIZE
			A

REV	DATE	BY	CHK	APR	DESCRIPTION	ECN
3	4-3-13	BJN	JSP	EJH	SEE SHEET 1 FOR REVISION HISTORY	02479-324

D:\10100DA\14