

SIRIUS

Leistungsschalter

Circuit-breaker

Disjoncteur

Interruptor automático / Guardamotor

Interruttore automatico

Disjuntor

3RV1.4



IEC/EN 60947-2
IEC/EN 60947-4-1

Betriebsanleitung
Instructivo

Operating Instructions
Istruzioni di servizio

Instructions de service
Instruções de Serviço

Bestell-Nr./Order No.: 3ZX1012-0RV04-1AA1

Vor der Installation, dem Betrieb oder der Wartung des Geräts muss diese Anleitung gelesen und verstanden werden.

Read and understand these instructions before installing, operating, or maintaining the equipment.

Ne pas installer, utiliser ou entretenir cet équipement avant d'avoir lu et assimilé ces instructions.

Leer y comprender este instructivo antes de la instalación, operación o mantenimiento del equipo.

Leggere con attenzione questi istruzioni prima di installare, utilizzare o eseguire manutenzione su questa apparecchiatura.

Ler e compreender estas instruções antes da instalação, operação ou manutenção do equipamento.

	⚠️ WARNING Gefährliche elektrische Spannung! Kann zu elektrischem Schlag und Verbrennungen führen. Vor Beginn der Arbeiten Anlage und Gerät spannungsfrei schalten.	⚠️ WARNING HAZARDOUS VOLTAGE. Can cause electrical shock and burns. Disconnect power before proceeding with any work on this equipment.	⚠️ ATTENTION Tension dangereuse ! Risque d'électrocution et de brûlure. Isoler cet appareil du réseau avant d'y intervenir pour travaux.
	⚠️ ADVERTENCIA ¡Tensión peligrosa! Puede causar choque eléctrico y quemaduras. Desconectar la alimentación antes de efectuar trabajo alguno en este equipo.	⚠️ ATTENZIONE Tensione elettrica pericolosa! Rischio di shock elettrico e ustioni. Prima di eseguire qualsiasi tipo di lavoro, assicurarsi che l'apparecchio e l'impianto siano scollegati.	⚠️ AVISO Tensão elétrica perigosa! Pode causar um choque elétrico e queimaduras. Antes de iniciar os trabalhos, desligue a tensão da unidade e do aparelho.

Eine sichere Gerätefunktion ist nur mit zertifizierten Komponenten gewährleistet.

Reliable functioning of the equipment is only ensured with certified components.

Le fonctionnement sûr de l'appareil n'est garanti qu'avec des composants certifiés.

El funcionamiento seguro del aparato sólo está garantizado con componentes certificados.

Il funzionamento sicuro dell'apparecchiatura viene garantito soltanto con componenti certificati.

O funcionamento seguro do aparelho apenas pode ser garantido se forem utilizados os componentes certificados.

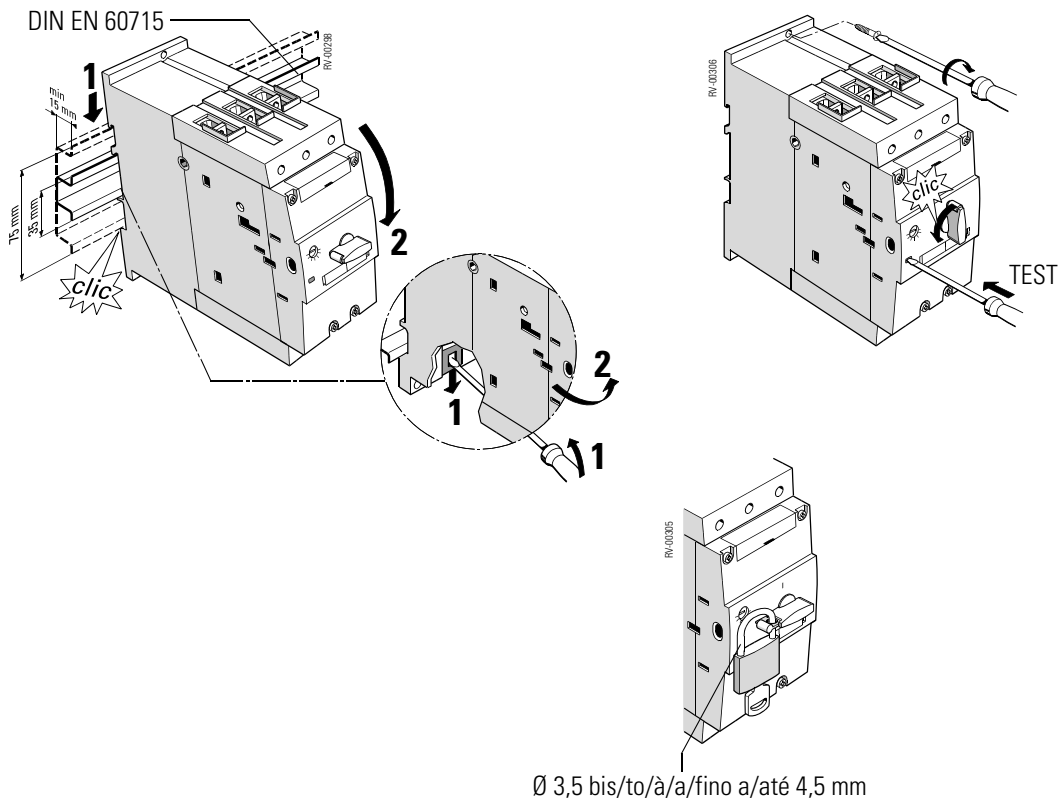

3RV1908-0P
1 Best. Nr. = 10 Stück
1 Order No. = 10 pieces
1 N° de référence = 10 pièces
1 Ref. = 10 piezas
1 N. di ordinaz. = 10 pezzi
1 N.º de enc. = 10 peças

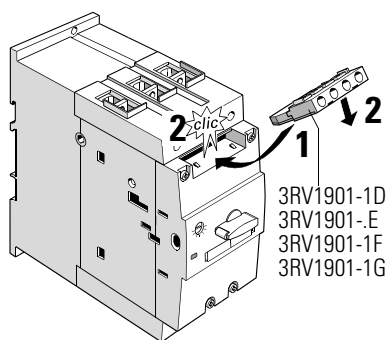
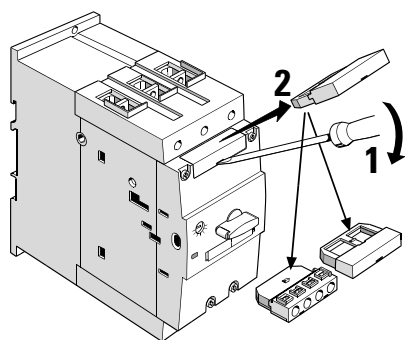
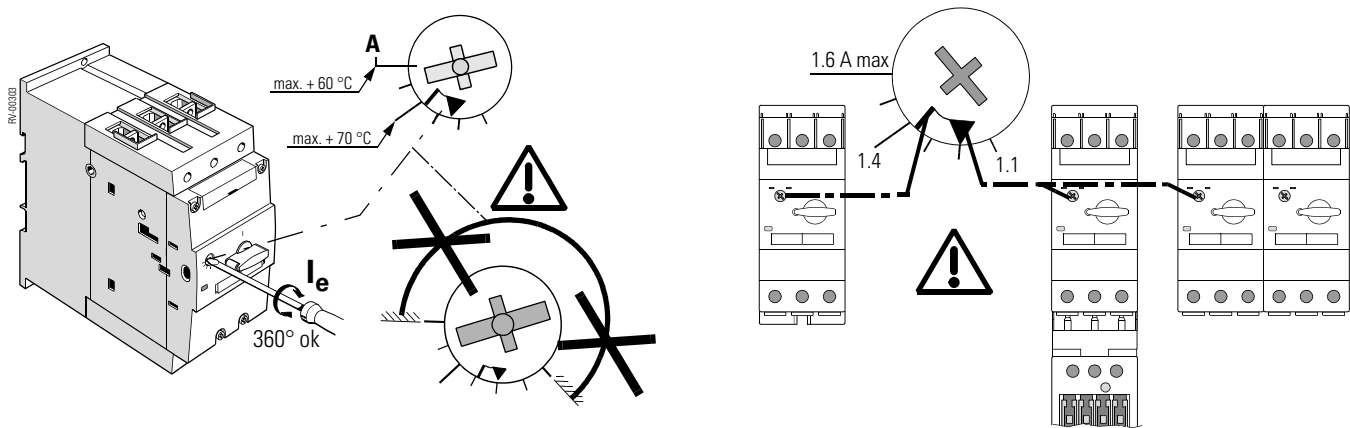

NC/NO: max. Stck. / pc.	
max.1: 3RV1901-A 3RV1901-B 3RV1901-C	max.1: 3RV1901-1D 3RV1901-E 3RV1901-1F 3RV1901-1G
max.1: 3RV1901-1J	—

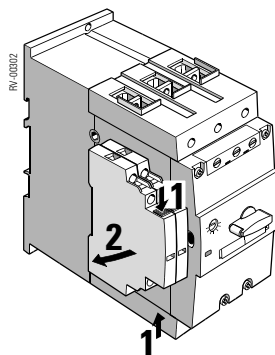
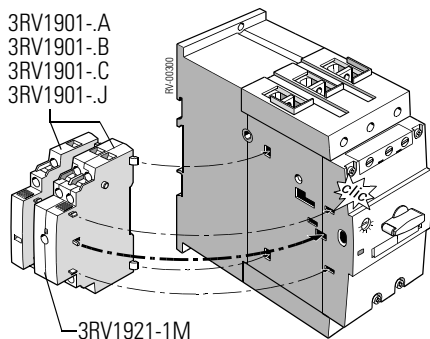

3RV1902-1.

3RV1141-....

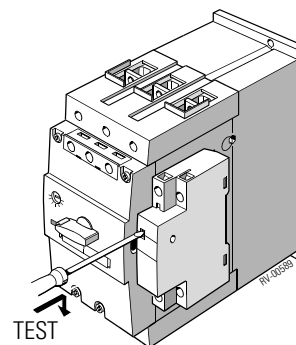
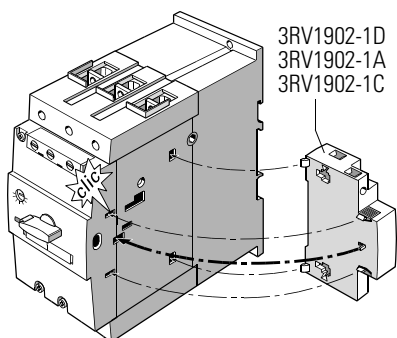

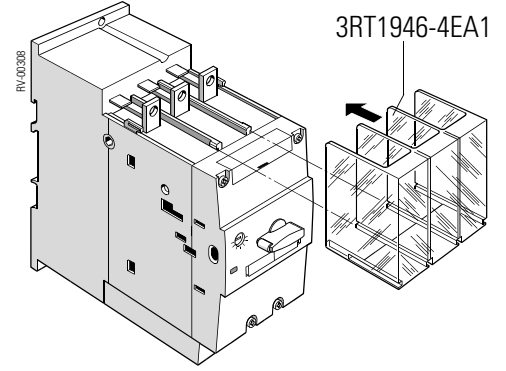
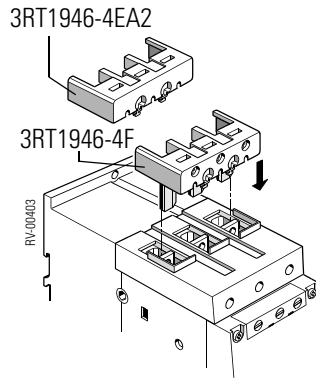
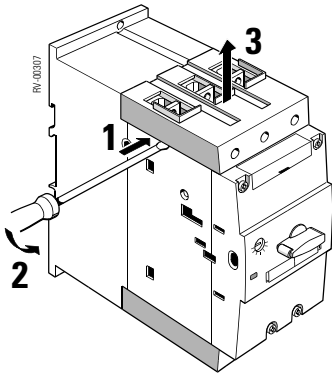

Montageanleitung 8ZX1012-0US10-1BA1
 Assembly Instructions 8ZX1012-0US10-1BA1
 Instructions 8ZX1012-0US10-1BA1
 Instrucciones de montaje 8ZX1012-0US10-1BA1
 Istruzioni di montaggio 8ZX1012-0US10-1BA1
 Manual de montaje 8ZX1012-0US10-1BA1

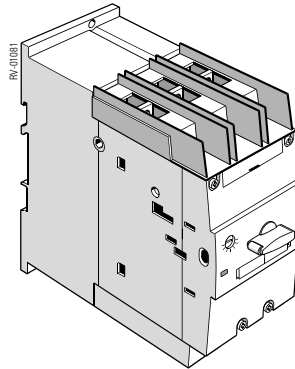
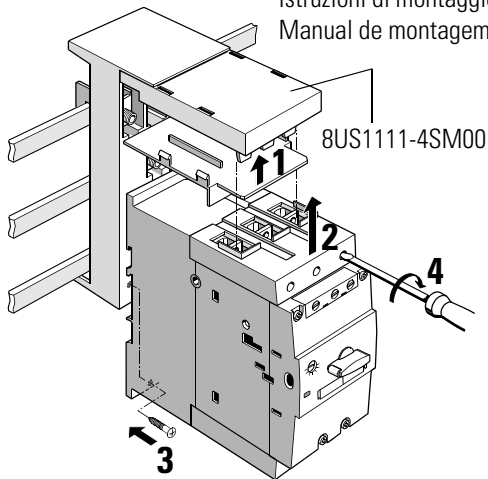

Self-Protected
 Combination
 Controller Type E



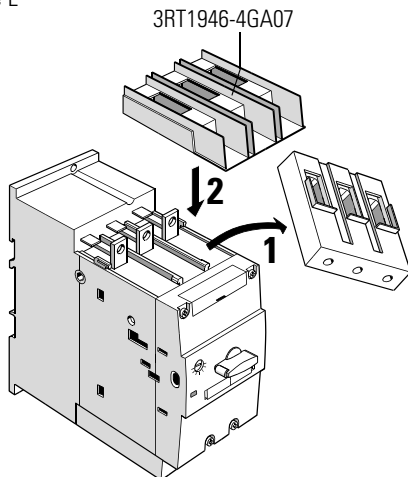



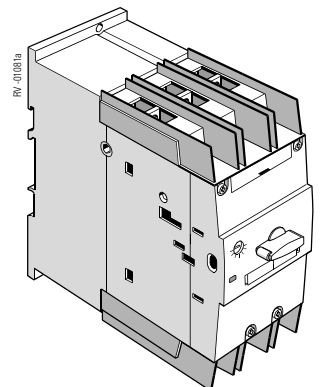

~~3RV1901-1D~~
~~3RV1901-E~~
~~3RV1901-1F~~
~~3RV1901-1G~~

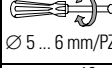

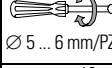
3RV1742... / UL 489

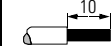
~~3RV1901-1D~~
~~3RV1901-E~~
~~3RV1901-1F~~
~~3RV1901-1G~~

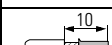

	L1, L2, L3 T1, T2, T3		D1, D2, C1, C2; NO/NC	
			3RV19...-1	3RV19...-2
	4 ... 6 Nm 35 ... 53 lb-in		0,8 ... 1,2 Nm 7 to 10.3 lb-in	—
	2 x 2,5 ... 16 mm ²		2 x 0,5 ... 1,5 mm ² 2 x 0,75 ... 2,5 mm ²	2 x 0,25 ... 2,5 mm ²
	2 x 2,5 ... 35 mm ² 1 x 2,5 ... 50 mm ²		2 x 0,5 ... 2,5 mm ²	2 x 0,25 ... 1,5 mm ²
	2 x 10 ... 50 mm ² 1 x 10 ... 70 mm ²	—	—	—
AWG	2 x 10 to 1/0 1 x 10 to 2/0	AWG	2 x 18 to 14	2 x 24 to 14

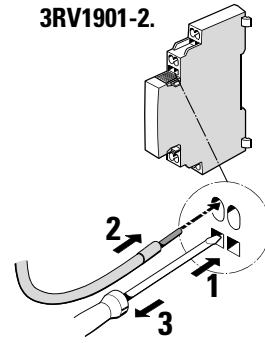

3RV104/144
3RV134 

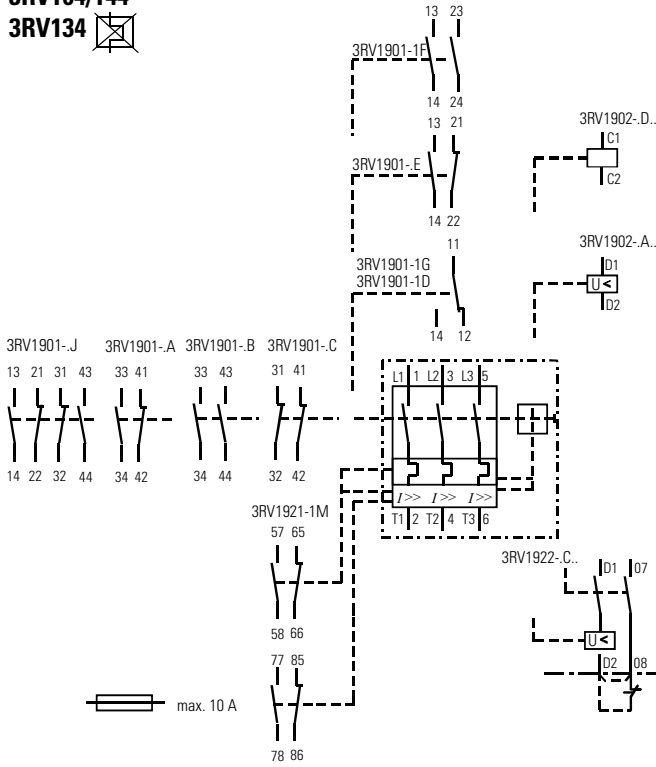

3RV1141-....

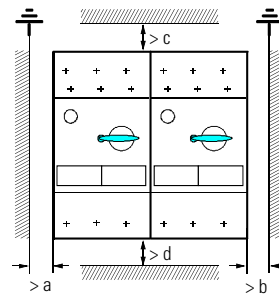
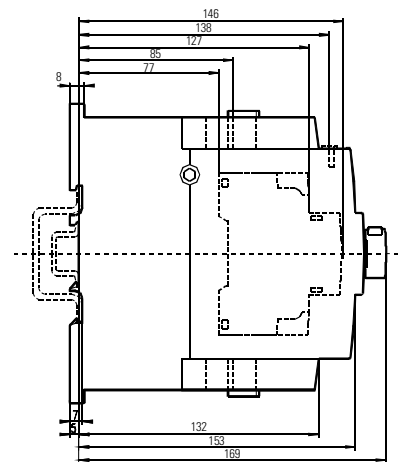
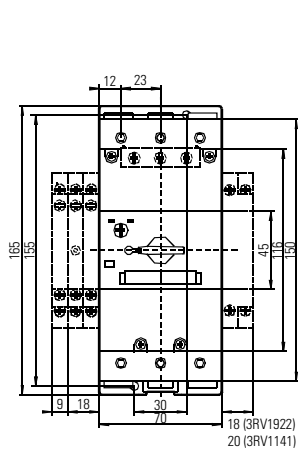
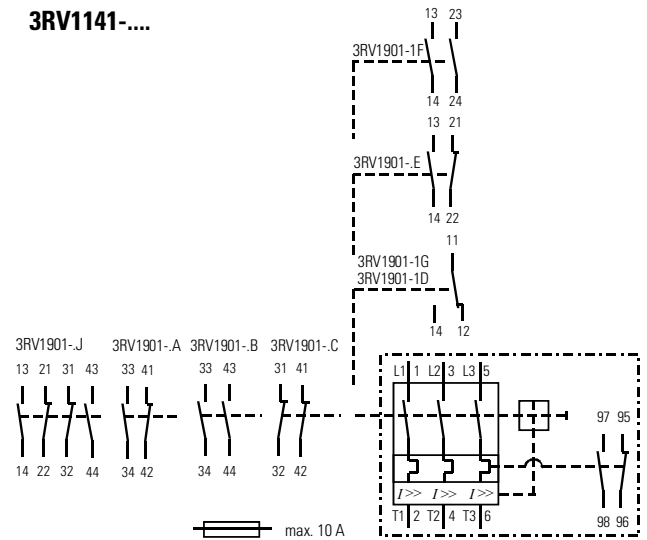

U _e (V)	a	b	c	d
240	10	10	50	50
400	10	10	70	70
440	10	10	70	70
500	10	10	110	110
690	30	30	150	150

Technical Assistance: Telephone: +49 (0) 9131-7-43833 (8°° - 17°° CET) Fax: +49 (0) 9131-7-42899
E-mail: technical-assistance@siemens.com
Internet: www.siemens.de/lowvoltage/technical-assistance

Technical Support: Telephone: +49 (0) 180 50 50 222

Technische Änderungen vorbehalten. Zum späteren Gebrauch aufbewahren.
Subject to change without prior notice. Store for use at a later date.
© Siemens AG 1997

Bestell-Nr./Order No.: 3ZX1012-0RV04-1AA1
Printed in the Federal Republic of Germany