

P2 & P3 Panelboard Kit BBKED32 For Branch Mounting of ED Breakers

DEADFRONT MODIFICATIONS AND PANEL RE-ASSEMBLY

10. Remove any full width plate covering the dead front area for the installed kit. On P2 dead fronts only, remove any center strips attached to the removed plate.

11. If the installed kit does not completely fill the unit space of a removed module, a dead front filler plate kit is required. Use DFFP3 for 3" gaps and DFFP6 for 6" gaps.

12. For P2 deadfronts only, use kit DFKI to install the appropriate length center strip to span any open dead front area.

13. Refer to figure 7. - On P3 dead fronts only, install two dead front adaptor plates (item 7) on the outside edges of the kit dead front area, at the kit unit space locating dimension D, as shown. Fasten the plates to the dead front with four 8-32 screws (item 8).

14. Replace the dead front using the hardware removed during disassembly.

15. Refer to figure 8. - Insert 1" dead front fillers (item 6) into all P2 & P3 dead front branch spaces not filled with breakers.

16. Tighten all hardware to the torque values specified on the back of the dead front.

15. Replace the panelboard front cover using the hardware removed during disassembly.

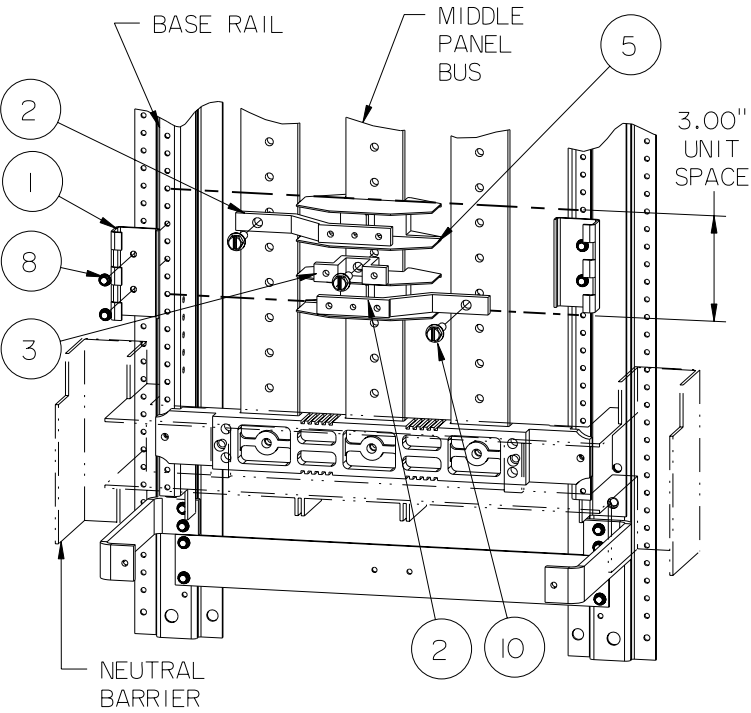

Figure 5

BRANCH BREAKER INSTALLATION - ALL PANELS

8. Refer to figure 6. - Position a branch breaker with each mounting notch on the load side of its case engaging a mounting tab on the breaker support (item 1) and with its line end angled upward to clear the branch barriers. Pivot the breaker about the support tabs to "rock" it into position, guiding the wings of the barriers as needed to allow each breaker pole to slide into the space between two wings. Bring each breaker line stab into contact with its connector bus and align each breaker stab hole with its corresponding connector bus hole.

9. Fasten each breaker line stab to its connector using a 10-24 X 5/8" screw (item 12), and tighten to the torque value specified on the back of the dead front.

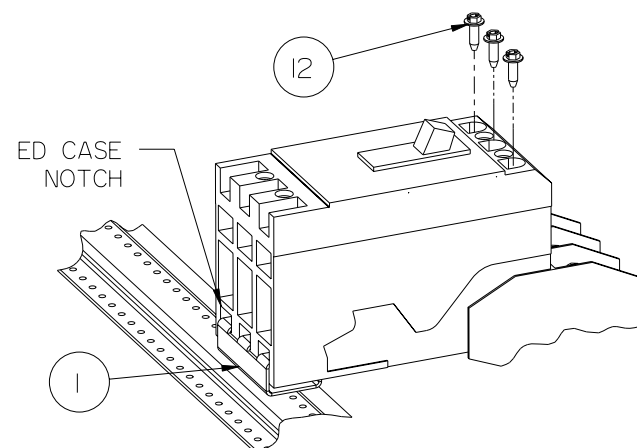

Figure 6

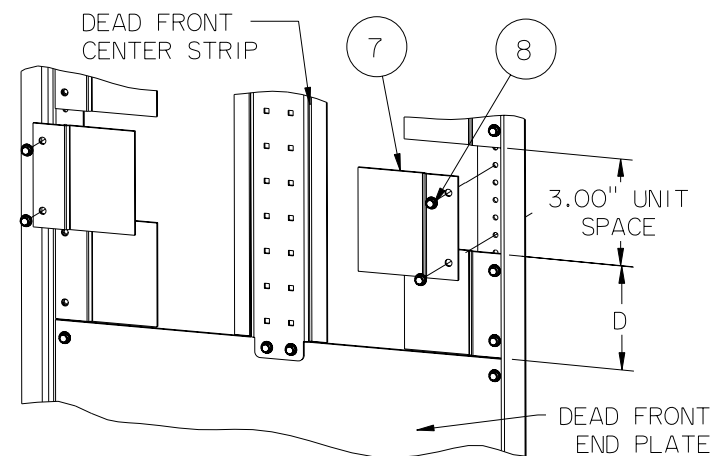

Figure 7

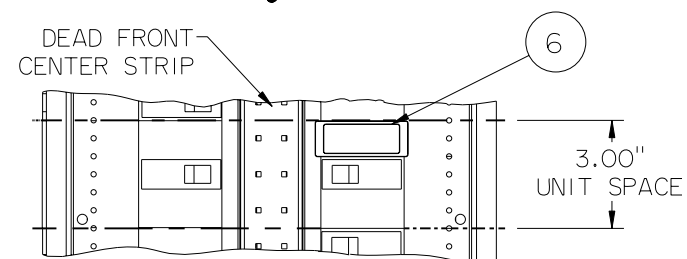

Figure 8

Installation Instructions

The following instructions are for installation of Siemens ED circuit breakers as branch devices in a Type P2 or a Type P3 panelboard. The parts provided in this kit connect ED breakers to 1-phase or 3-phase systems. The breakers are not included in this kit and must be purchased separately. This kit requires 3" of branch unit space. If the unit space location for the kit is presently covered on the dead front by a single, full width plate, a P2 dead front will require modifications using kit DFK1. Both P2 and P3 dead fronts will need a blank filler plate if this kit incompletely fills the interior unit space of any removed branch module(s). These dead front filler kits are DFFP3 for a 3" gap and DFFP6 for a 6" gap. In P2 panelboards, use kit BNK2 if the branch neutral lugs do not have enough available sites for the breakers installed with this kit.



DANGER

Hazardous voltage. Will cause death or serious injury.

Keep out. Qualified personnel only. Disconnect and lock off all power before working on this equipment.

1. Lock off power supplying this equipment before working on it.

2. Remove the panelboard front cover and dead front.

3. Refer to fig.1 - For taking unit space measurements in P2 panels, use the bus support located farthest from the main lug or device end of the panel. For P3 panels, use the neutral barriers if present, or the bus supports in panels without neutrals. Note that unit space starts at the inner surface of a P3 neutral barrier and 0.25" from the inner surface of a P2 or P3 bus support.

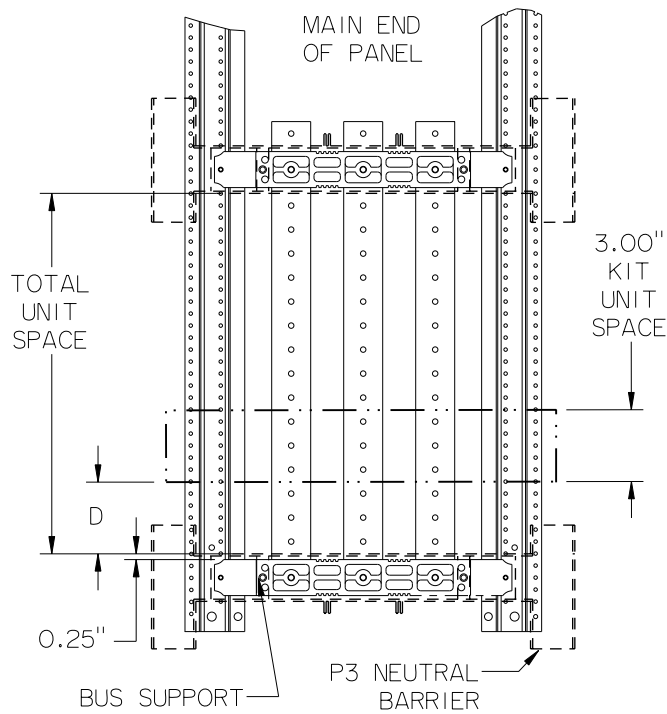

Figure 1

4. This kit requires 3" of unit space. Determine the location where the kit is to be installed. The kit positioning dimension D in fig. 1, must be a multiple of 3" (0", 3", 6", 9", etc.).

These measurements can be taken directly from a P3 neutral barrier. For measurements taken from a P2 or P3 bus support, add 0.25" to D (0.25", 3.25", 6.25", 9.25", etc.)

5. If an existing branch module occupies the location chosen for this kit, remove all of its devices, components and parts. If it is a 6" module, the entire 6" of unit space must be cleared.

THIS KIT CONTAINS THE FOLLOWING ITEMS

| ITEM # | DESCRIPTION | QTY. |
|--------|------------------------------------|------|
| 1 | ED Breaker Support | 2 |
| 2 | Outer Connector Bus | 3 |
| 3 | Center Connector Bus | 1 |
| 4 | ED Branch 1 ϕ System Barrier | 2 |
| 5 | ED Branch 3 ϕ System Barrier | 2 |
| 6 | 1" Unit Space Dead Front Filler | 6 |
| 7 | P3 Panel Dead Front Adaptor Plate | 2 |
| 8 | 8-32 X 9/32" Self-threading Screw | 8 |
| 9 | 1/4-20 X 5/8" Self-threading Screw | 3 |
| 10 | 1/4-20 X 1" Self-threading Screw | 3 |
| 11 | 8-32 X 5/8" Self-threading Screw | 2 |
| 12 | 10-24 X 5/8" Self-threading Screw | 6 |

NOTE: Separate instructions are provided for kit installation for each system and panel type. Each application uses some, but not all of the above listed parts. Instructions for breaker installation and panel re-assembly are located on page 4.

INSTALLATION IN P2 1-PHASE PANELS

6. Refer to fig. 2. - Position the two breaker supports (item 1) on the base rails in the center of the 3" kit unit space as shown. Fasten them to the base rails using four 8-32 screws (item 8). Install the three outer connectors (item 2), alternating between the left and right panel bus. The left-right-left connector pattern may be reversed to continue a pattern already in place in the panel. Fasten the connectors to the panel bus with three 1/4-20 X 5/8" screws. (item 9).

CAUTION

Arcing Hazard. May cause injury or property damage.

Use 5/8" long screws (item 9) in Type P2 5-3/4" deep panelboards to fasten the connectors.

7. Place two 1 ϕ branch barriers (item 4) on the top and bottom connectors, and fasten them with two 8-32 X 5/8" screws (item 11). Keeping the connectors perpendicular to the panel bus, tighten all screws to the torque values specified on the back of the dead front.

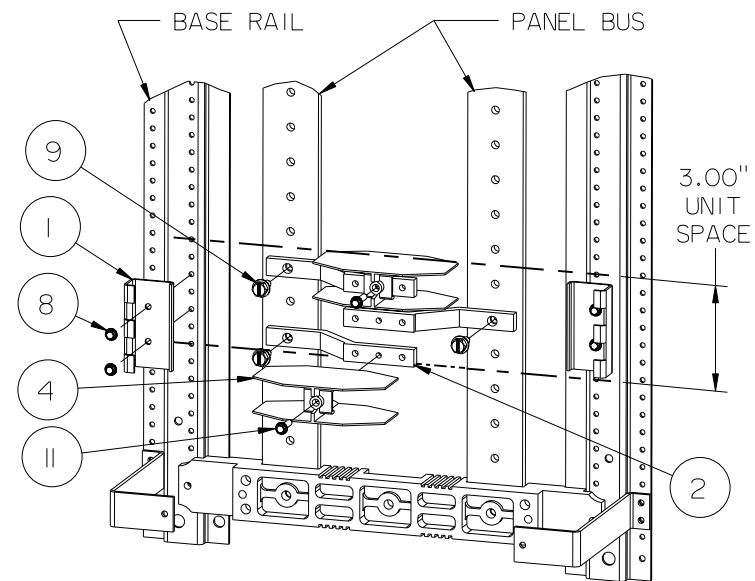

Figure 2

INSTALLATION IN P2 3-PHASE PANELS

6. Refer to fig. 3. - Position the two breaker supports (item 1) on the base rails in the center of the 3" kit unit space as shown. Fasten them to the base rails using four 8-32 screws (item 8). Install the two ED branch 3 ϕ system barriers (item 5) at the upper and lower edges of the 3" kit unit space by inserting their pins completely into the corresponding holes in the middle panel bus. Position the two outer connectors (item 2) within the barriers, and the center connector (item 3) between the barriers. Fasten the connectors to the panel bus with three 1/4-20 X 5/8" screws (item 9).

CAUTION

Arcing Hazard. May cause injury or property damage.

Use 5/8" long screws (item 9) in Type P2 5-3/4" deep panelboards to fasten the connectors.

7. Keeping all connectors perpendicular to the panel bus, tighten all screws to the torque values specified on the back of the dead front.

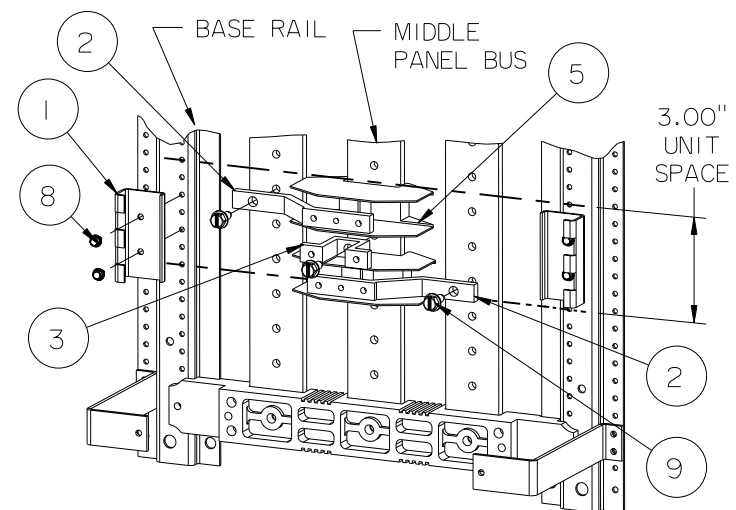

Figure 3

INSTALLATION IN P3 1-PHASE PANELS

6. Refer to fig. 4. - Position the two breaker supports (item 1) on the base rails in the center of the 3" the kit unit space as shown. Fasten them to the base rails using four 8-32 screws (item 8). Install the three outer connectors (item 2), alternating between the left and right panel bus. The left-right-left connector pattern may be reversed to continue a pattern already in place in the panel. Fasten the connectors to the panel bus with three 1/4-20 X 1" screws. (item 10).

CAUTION

Arcing Hazard. May cause injury or property damage.

Use 1" long screws (item 10) in Type P3 7-3/4" deep panelboards to fasten the connectors.

7. Place two 1 ϕ branch barriers (item 4) on the top and bottom connectors, and fasten them with two 8-32 X 5/8" screws (item 11). Keeping the connectors perpendicular to the panel bus, tighten all screws to the torque values specified on the back of the dead front

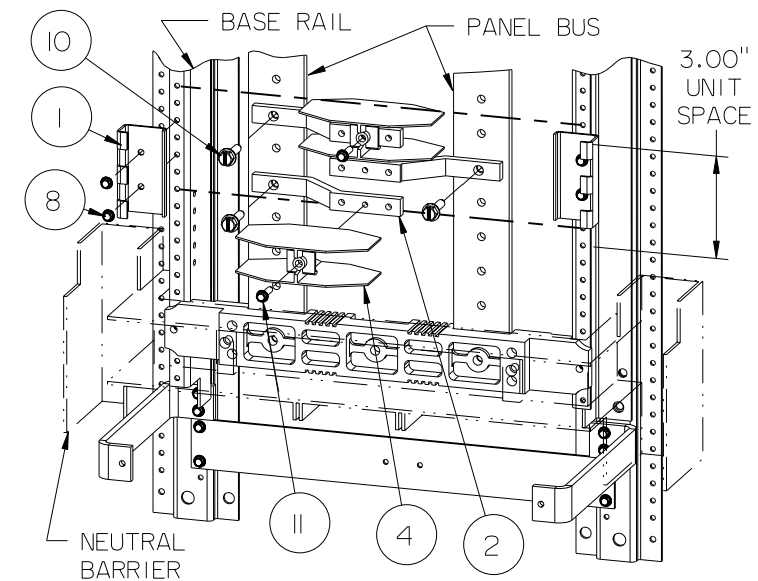

Figure 4

INSTALLATION IN P3 3-PHASE PANELS

6. Refer to fig. 5. - Position the two breaker supports (item 1) on the base rails in the center of the 3" kit unit space as shown. Fasten them to the base rails using four 8-32 screws (item 8). Install the two ED branch 3 ϕ system barriers (item 5) at the upper and lower edges of the 3" kit unit space by inserting their pins completely into the corresponding holes in the middle panel bus. Position the two outer connectors (item 2) within the barriers, and the center connector (item 3) between the barriers. Fasten the connectors to the panel bus with three 1/4-20 X 1" screws (item 10).

CAUTION

Arcing Hazard. May cause injury or property damage.

Use 1" long screws (item 10) in Type P3 7-3/4" deep panelboards to fasten the connectors.

7. Keeping all connectors perpendicular to the panel bus, tighten all screws to the torque values specified on the back of the dead front.