

DEAD FRONT KNOCKOUT REMOVAL INSTRUCTIONS

11. Stand the deadfront on the floor with the plate to be removed in the upper position as shown below. Grasping the upper edge of the deadfront, strike the center of the front surface of the knockout plate with a hammer until two of the plate attachment splices are broken.
12. Bend the plate back-and-forth about the two remaining attachments until the plate breaks free.

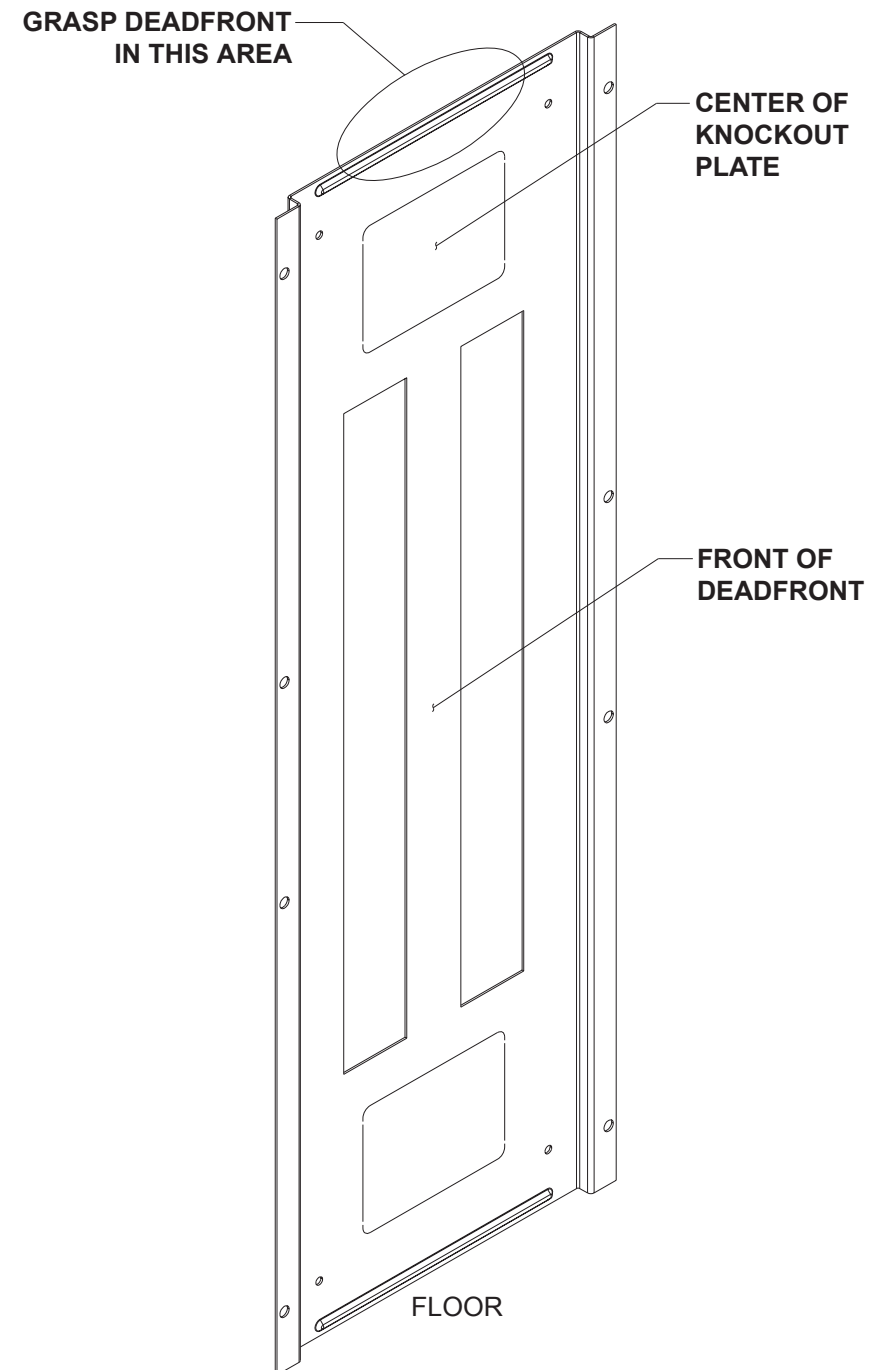

SIEMENS

S1 and P1 Panelboard Kit MBKBL3 for Main or Subfeed BL breakers

Installation
Instructions

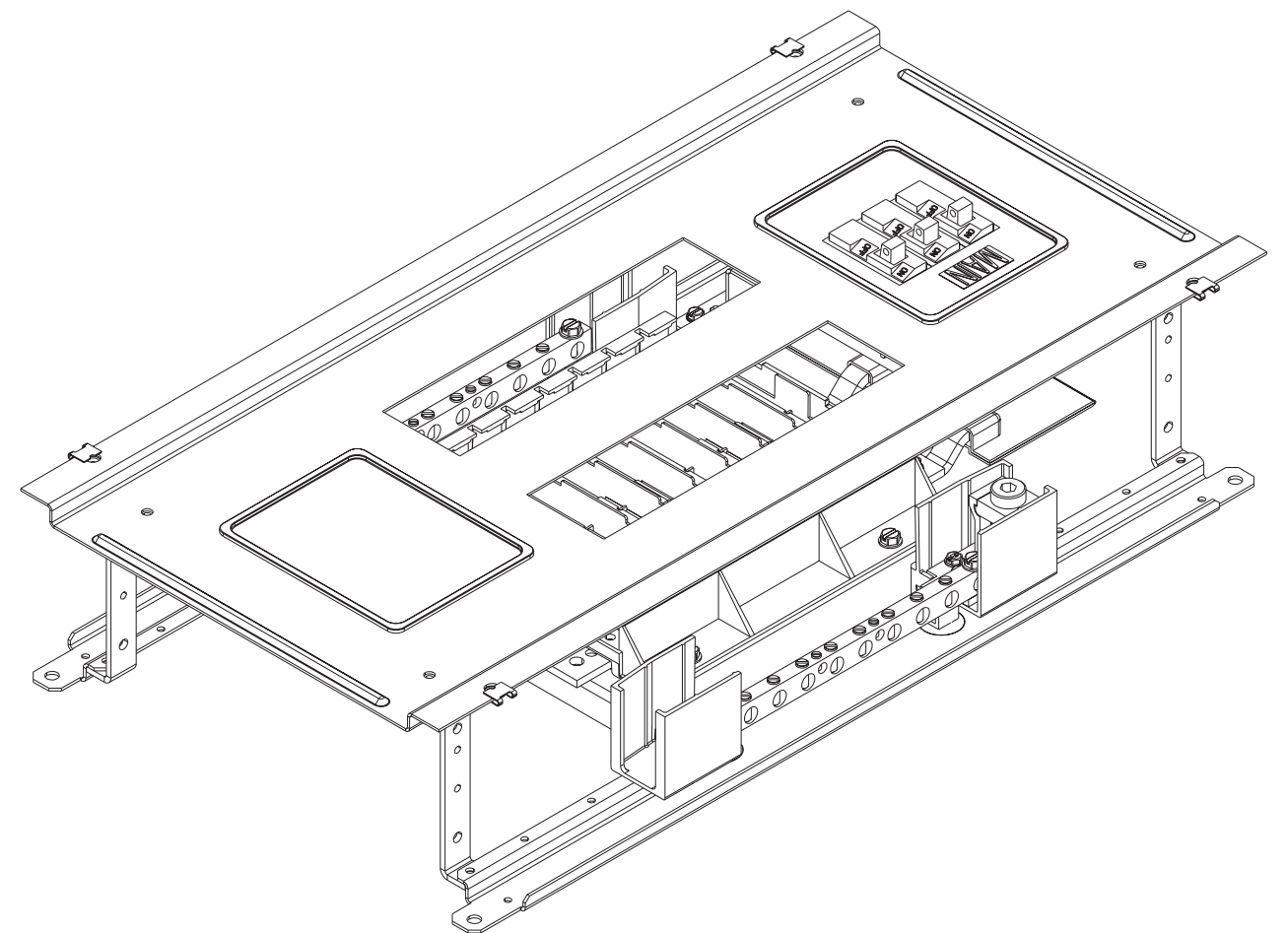

Installation Instructions

The following instructions are for the installation of a Siemens main/subfeed breaker kit for BL, HBL, BLH breakers in S1 and P1 (240V Maximum) Type panelboards. The kit may be installed as a main or a subfeed in panels rated 250 amps or less. Above 250 amps it may be installed in subfeed applications only. The parts provided in this kit are for connection to a 3 phase 3 or 4 wire system. The breaker is not included with this kit and must be purchased separately. Be sure to choose the appropriate breaker for the system in use. For 3 wire systems, disregard the neutral connection.



⚠ DANGER
Hazardous voltage. Will cause death or serious injury.
 Keep out.
 Qualified personnel only.
 Disconnect and lock off all power before working on this equipment.

the instructional drawing). If it is desirable to place the lug at the other corners of the panel, the lug may be disassembled and the lug pad flipped 180 degrees and re-assembled. See instructional drawing below. Follow the torque values specified on the installation and maintenance label. The lug may be attached to the neutral cross bar at any open corner using the #10-24 slotted hex head thread forming screws (Item 9) provided. Again, follow the torque values specified on the installation and maintenance label.

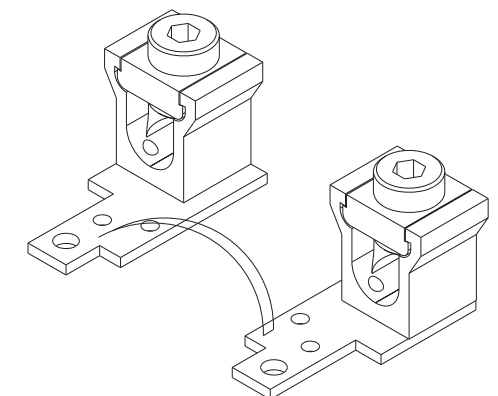

NEUTRAL LUG DETAIL

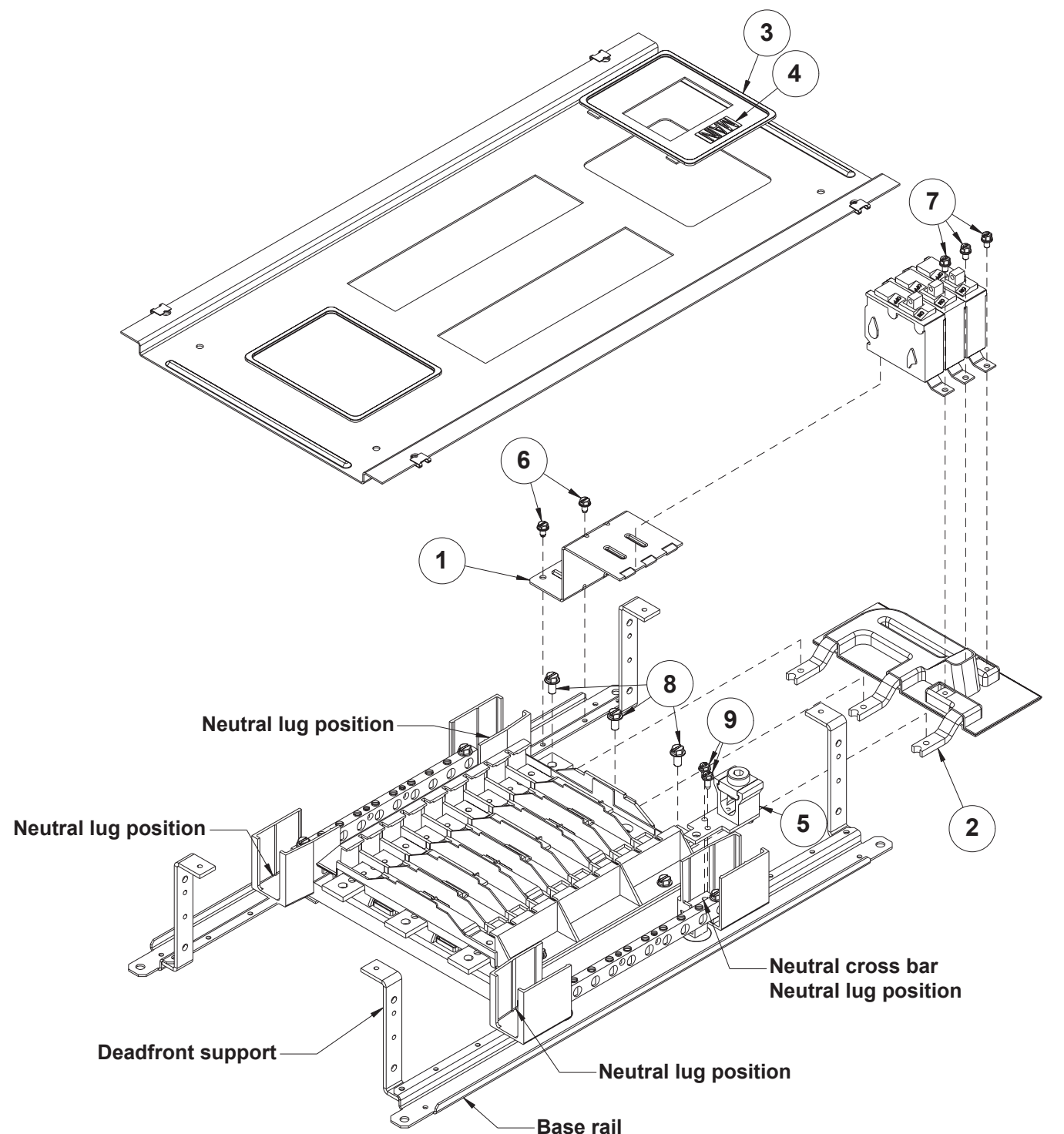

* SEMS ASSEMBLY SCREWS HAVE A CAPTIVE WASHER ON THE SCREW.

ITEM	DESCRIPTION	QTY
1	BREAKER SUPPORT	1
2	BREAKER CONNECTOR ASSEMBLY	1
3	COVER PLATE	1
4	MAIN LABEL	1
5	NEUTRAL LUG ASSEMBLY	1
6	#10-32 SLOTTED HEX WASHER HEAD THREAD FORMING SCREW	2
7	#10-32 HEX HEAD SEMS ASSEMBLY MACHINE SCREW*	3
8	1/4-20 X 1/2 HEX HEAD SEMS ASSEMBLY MACHINE SCREW*	3
9	#10-24 X 7/16 SLOTTED HEX WASHER THREAD FORMING SCREW	2

- For installation as a main breaker (250A and lower panels only).** Lock off all power supplying this equipment before working on it. To install this kit as a main breaker, remove the deadfront and main lugs if installed. Place the main breaker connector assembly (Item 2) so that the ends of the assembly with the half holes are positioned under the section or main bus. Fasten to the main bus using the 1/4-20 hex head SEMS assembly machine screws (Item 8) provided. Take care to see that the half hole engages the anti-turn tab on the underside of the section bus. **DO NOT TIGHTEN AT THIS TIME.**
- Attach the breaker support (Item 1) to the base rail using (2) of the #10-32 slotted hex washer head thread forming screws (Item 6) provided as shown on page 2.
- Position the breaker on the breaker support (Item 1) and attach to the connector assembly using the #10-32 slotted hex head SEMS assembly machine screws (Item 7) provided.
- Torque all connections to the values specified on the installation and maintenance instruction label affixed to the rear of the deadfront.
- Attach the main or branch cables to the breaker and torque connections to the values specified on the device, or if no values are specified on the device, refer to the installation and maintenance instructions affixed to the rear of the deadfront of the panel.
- Remove the insert plate installed in any deadfront opening in the area that will cover this kit. If there is no opening, follow the instructions on page 4 to remove the main/ subfeed knockout. Install the cover plate (Item 3) provided with this kit into the front of the dead front as shown by inserting two plate edge tabs into one edge of the cutout and then snapping the other two tabs in place. For main breaker applications, apply the "MAIN" label (Item 4) to the cover plate (Item 3) as shown.
- On 4 wire systems the neutral lug (Item 5) is required. The neutral lug assembly comes in the kit ready to assemble on the upper right or the lower left position of the neutral bus (Note Neutral positions shown on

- Before energizing the panel, ensure that all connections have been torqued and that the deadfront is installed.
- Installation as a subfeed breaker.** Follow steps (1) through (8) except that any subfeed breakers or feed thru lugs assemblies existing in the panel are removed. In addition, do not install the "MAIN" label.
- In panels rated higher than 250A, kits mount only at the end of the interior designated for subfeeds. See reference drawing below. Kit connectors fasten to the end holes in the panel phase bus, the breaker support fastens to the two base rail holes nearest the deadfront support, and the neutral lug, if installed, fastens to the diagonal hole pattern on the neutral lug pad.

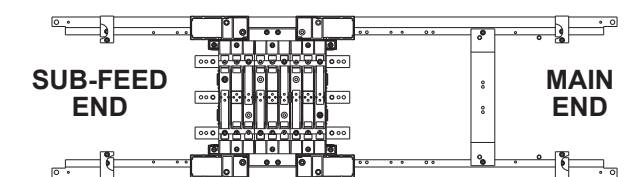

400A P1 PANELBOARD INTERIOR