

INSTRUCTION/INSTALLATION SHEET

Selective Call Intercom Video Door Unit

IS-0426 REV. O

1. Introduction

The On-Q /Legrand Selective Call Intercom Video Door Unit, PN IC5003-XX (see **Figure 1**), is a weather resistant door unit that allows a visitor to notify the occupants of their presence by pushing the door chime button. The occupants can then see who is at the door via the optional On-Q LCD Console and associated module, initiate two-way communications with the visitor and optionally open the door (requires separate door release device). The Door Unit is available in white (-WH), shiny brass (-SB), antique brass (-AB), brushed stainless (-BS) and oil-rubbed bronze (-OB).



Figure 1

2. Description

The Video Door Unit is a 2-gang product that mounts within a two-gang electrical box (56" from the floor to the bottom of the box). There is also a two-gang surface-mount box available (P/N IC5006-BK) for unique or retrofit installation requirements.

3. Installation

Installation of the Selective Call Video Door Unit is best accomplished at multiple times during new construction, at "Rough-in" before the drywall and siding is installed, and at "Trim-out" after the drywall is installed.

A. "Rough-in" steps:

1. Run a Cat 5 cable from the Enclosure where the Selective Call Intercom Module will be installed to the 2 gang box at the Video Door Unit location.

NOTE: A single Video Door Unit in a one Module system may be run up to 650 feet from the Module to support a gate application. All other Door Units on the system must be within 330 feet (100 meters) of the Distribution Module.

NOTE: It is important to keep all Category 5e cable runs, regardless of use, at least 12 inches away from AC electrical cables. If it proves necessary to cross an existing AC cable, do so only at a 90 degree angle.

B. "Trim-out" steps:

NOTE: All terminations can be correctly completed by following the T568A pin assignments. It is important that you accurately terminate using T568A at all locations. All terminations on the Selective Call Intercom System utilize RJ45 jacks. Refer to **Figure 2 for correct T568A termination for RJ45 plugs.**

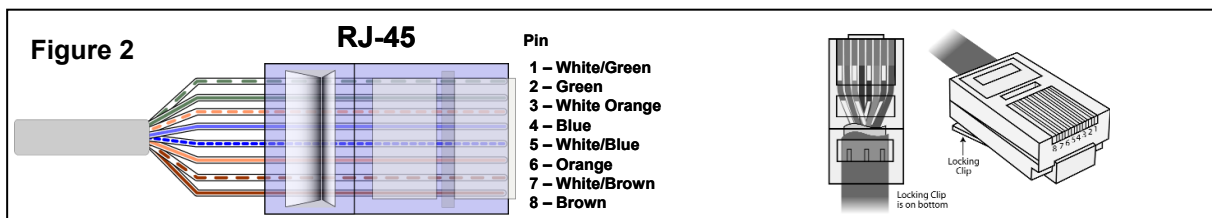

INSTRUCTION/INSTALLATION SHEET Selective Call Intercom Video Door Unit

IS-0426 REV. 0

NOTE: Make sure that the included weather proofing gasket is placed as shown in Figure 3.

- As shown in **Figure 3**, the first step to installing the Selective Call Video Door Unit is to place the included rear gasket against the gang or back box, and secure the gasket in place with the included mounting bracket.

NOTE: Insure that the mounting bracket is installed with the center tab pointed up, as the Video Door Unit will be "hung" from this tab in a later step.

NOTE: There are slotted holes in the mounting bracket to allow for leveling of the Video Door Unit in case the gang or back box was installed off level.

- Use the four provided screws to attach the mounting bracket to the gang or back box.

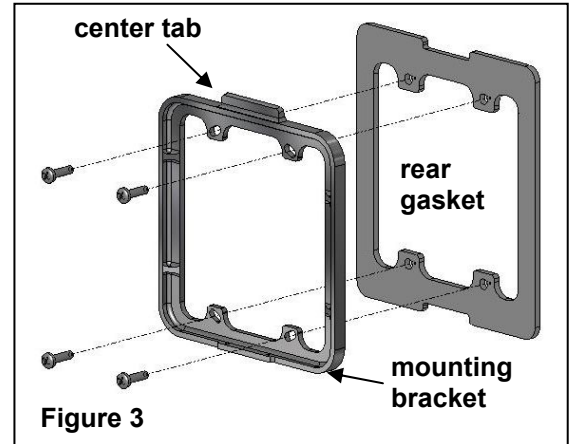

- Pull the Cat 5 cable from the enclosure through the mounting bracket and terminate the cable with an RJ45 plug and insert the plug into the RJ45 jack on the rear of the Video Door Unit (see **Figure 4**). Follow the T568A standards described in **Figure 2**.

NOTE: There is a four position terminal block on the rear of the Video Door Unit that can be utilized for two different purposes (see **Figure 5**). The CHIME output is a normally open dry contact closure used to ring a customers 3rd party door chime when the Video Door Unit button is pressed. The SENSOR input is reserved for a future application.

- Hang the Video Door Unit from the top tab on the mounting bracket and use the provided 1/16" allen wrench to tighten the two set screws at the bottom of the Video Door Unit.
- Terminate the other end of the Cat 5 cable, at the Selective Call Intercom Module, with an RJ45 plug using the T568A wiring standard (see **Figure 6**).

- Insert the RJ45 plug into jack #8 on the SCI Intercom Module (labeled 8/V1).



- After all Units and Modules are connected, apply power to the Selective Call Intercom Module and verify system functionality.

All Selective Call Room, Door and Patio Units will be discovered and shown on each Room Unit LCD.

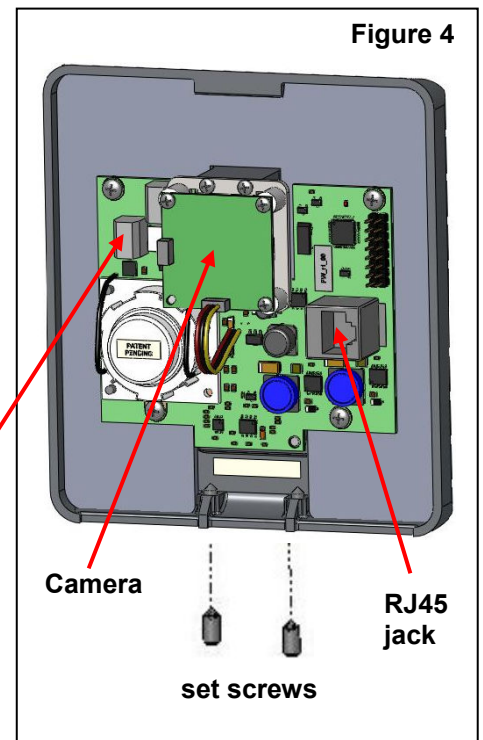

INSTRUCTION/INSTALLATION SHEET Selective Call Intercom Video Door Unit

IS-0426 REV. O

Figure 6

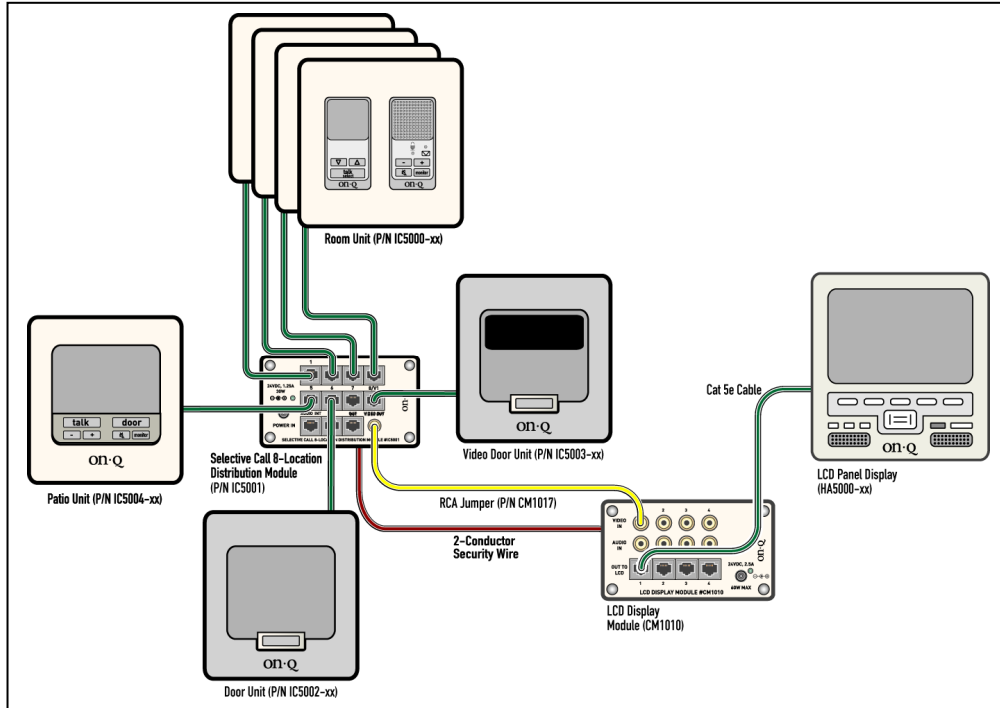

4. Operation

Please refer to **Figure 7** to familiarize yourself with the basic operation of the Selective Call Video Door Unit. Please refer to the Selective Call System Installation Manual (P/N 1308003) shipped with the Room Unit for more detailed instructions on how to use any Selective Call Room Unit to configure and personalize the Selective Call System. Refer to the Selective Call System User Manual (P/N 1308001) shipped with the Selective Call Module to familiarize yourself with the operation of the Selective Call Intercom System.

NOTE: Refer to the **Selective Intercom 8 Location Distribution Module Information Sheet (IS-0385)** shipped with the Distribution Module for information regarding the support for electronic door release functionality.

Figure 7

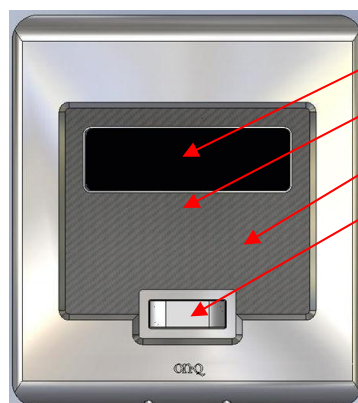

- Camera**
- Microphone**
- Speaker**

Door Chime Button: When a visitor pushes this button, one of 20 selectable Door Chimes will be heard throughout the home at each active intercom unit. The occupants of the home can then talk to that Video Door Unit from any Room or enabled Patio Unit. The visitor will hear the occupant over the Video Door Unit speaker and be able to talk to them over the Video Door Unit microphone. The occupant may also choose to release the electronic door latch (if equipped) and let the visitor in.