

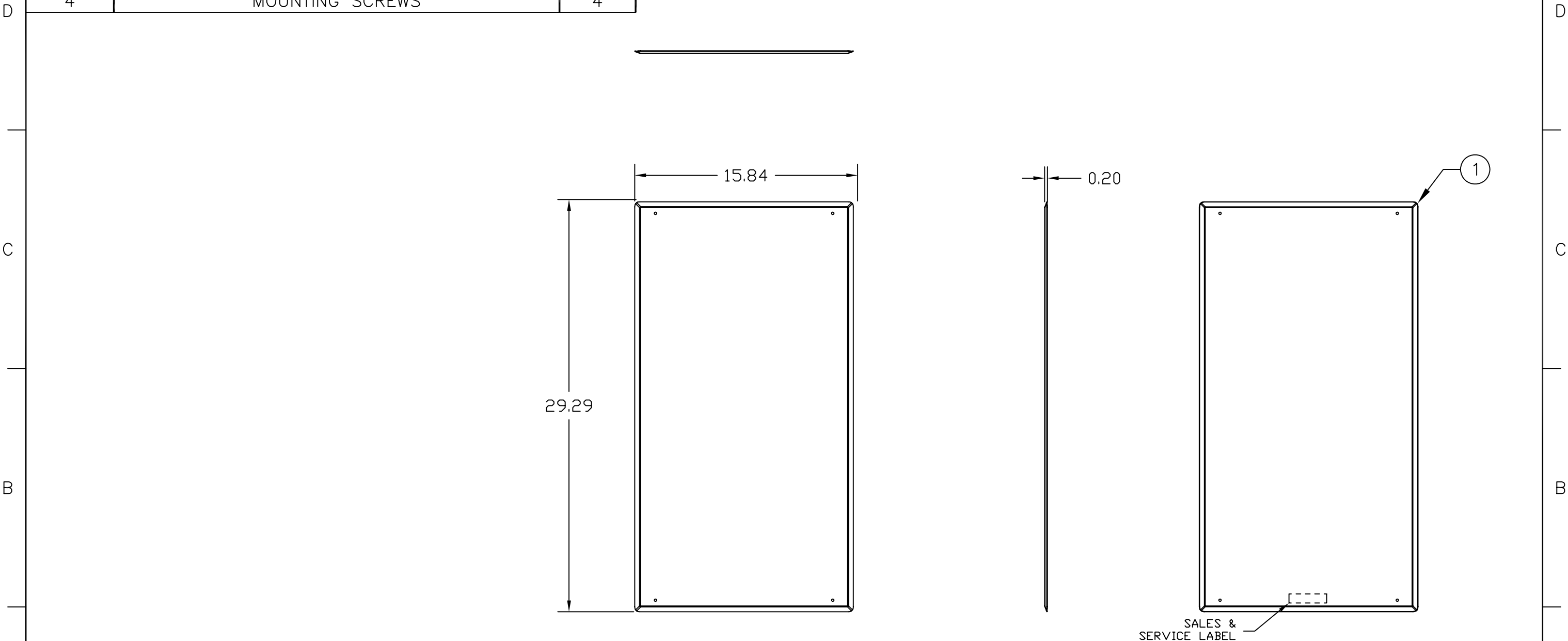

ITEM NO.	DESCRIPTION	QTY.	CATALOG NUMBER	DESCRIPTION
1	COVER	1	NSOBOX28C	28" PANEL COVER
2	WIRING LABEL (NOT PICTURED)	1		
3	INSTRUCTION SHEET (NOT PICTURED)	1		
4	MOUNTING SCREWS	4		



NOTES:
1. SPECIFICATIONS SUBJECT TO CHANGE WITHOUT NOTICE.
2. COMPATIBLE WITH NSOBOX28 SERIES PRODUCTS.

Created on AUTOCAD	DIMENSIONING AND TOLERANCE PER ANSI Y14.5M-1982 UNLESS OTHERWISE SPECIFIED, DIMENSIONS ARE IN INCHES (MM). TOLERANCES .XX = ±.01 (.25) .XXX = ±.005 (.127) .XXXX = ±.0025 (.0635) ANGLE TOL ±1'		PROJECT REFERENCE: 017-07		 Hubbell Premise Wiring HUBBELL INCORPORATED (Delaware) 14 Lord's Hill Road, Stonington, Connecticut 06378
	IN ACCEPTING OUR DRAWINGS, BLUEPRINTS, OR SUPPORTING DOCUMENTATION FOR QUOTATION OR OTHER PURPOSES, YOU AGREE NOT TO DISCLOSE TO OTHERS THE IDEAS, INFORMATION, OR DESIGNS SHOWN HEREIN, AND THAT YOU WILL MAKE NO USE OF SAME WITHOUT PERMISSION		MATERIAL: 18 Ga. COLD ROLLED STEEL		
			DRAWN BY: C. GRIBBLE 3/21/07		SIZE: B
			CHECKED BY:		DRAWING NO. HWS1252702C
		APPROVED BY:		SCALE: .15/1	
				SHEET 1 OF 1	
				REV. A	

A	6066	3/21/07	INITIAL RELEASE	CG	
REV.	ECN	DATE	DESCRIPTION	CHG BY	APPD BY