

RIGID PVC CONDUIT FITTINGS

ISSUE DATE:
DATE D'EMISSION: 2014 07 23

TYPE "TB" ACCESS FITTINGS

SUPERCEDES:
REPLACE: 2001 02 28

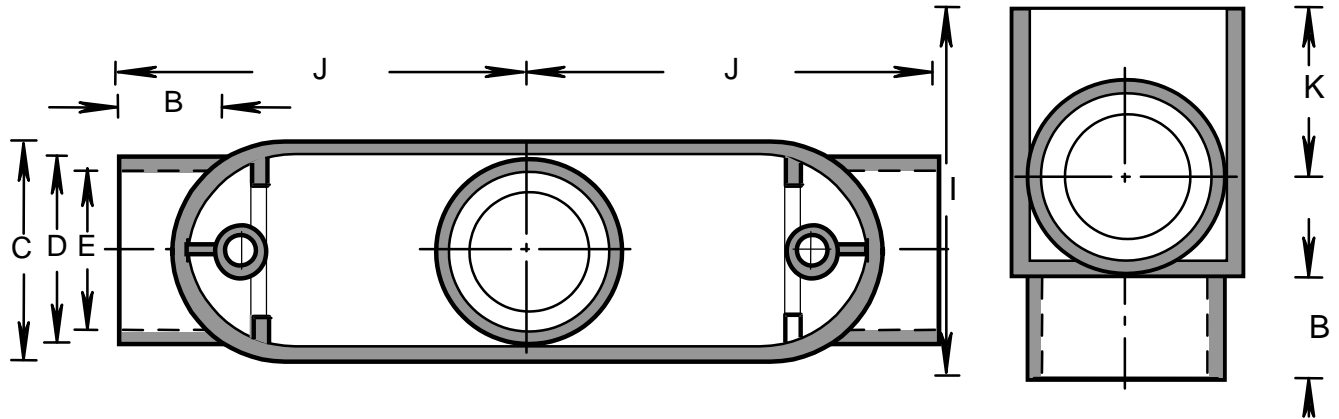

| PRODUCT CODE | PART NUMBER | NOMINAL SIZE | | A | | B | | C | | D | |
|--------------|-------------|--------------|------|--------|-------|-------|------|-------|------|-------|------|
| | | (in) | (mm) | (in) | (mm) | (in) | (mm) | (in) | (mm) | (in) | (mm) |
| 077452 | STB20S | 3/4 | 21 | 5.606 | 142.4 | 0.810 | 20.6 | 1.540 | 39.1 | 1.325 | 33.7 |
| 077456 | STB60S | 2 | 53 | 10.875 | 276.2 | 1.160 | 29.5 | 3.190 | 81.0 | 2.820 | 71.6 |

| PRODUCT CODE | PART NUMBER | NOMINAL SIZE | | E | | F | | G | | H | |
|--------------|-------------|--------------|------|-------|------|--------|-------|-------|-------|-------|------|
| | | (in) | (mm) | (in) | (mm) | (in) | (mm) | (in) | (mm) | (in) | (mm) |
| 077452 | STB20S | 3/4 | 21 | 1.050 | 26.7 | 5.395 | 137.0 | 4.095 | 104.0 | 1.297 | 32.9 |
| 077456 | STB60S | 2 | 53 | 2.375 | 60.3 | 10.530 | 267.5 | 8.160 | 207.3 | 2.350 | 59.7 |

| PRODUCT CODE | PART NUMBER | NOMINAL SIZE | | I | | J | | K | | WALL THICK. | |
|--------------|-------------|--------------|------|-------|-------|-------|-------|-------|------|-------------|------|
| | | (in) | (mm) | (in) | (mm) | (in) | (mm) | (in) | (mm) | (in) | (mm) |
| 077452 | STB20S | 3/4 | 21 | 2.490 | 63.2 | 2.800 | 71.1 | 1.005 | 25.5 | 0.125 | 3.2 |
| 077456 | STB60S | 2 | 53 | 4.535 | 115.2 | 5.440 | 138.2 | 1.970 | 50.0 | 0.203 | 5.2 |

| PRODUCT CODE | PART NUMBER | NOMINAL SIZE | | FILL VOLUME | | INSERT | SCREW | COVER | GASKET |
|--------------|-------------|--------------|------|-------------|---------|--------|--------|--------|--------|
| | | (in) | (mm) | (cu.in) | (cu.cm) | CODE | CODE | CODE | CODE |
| 077452 | STB20S | 3/4 | 21 | 7.5 | 123.0 | 072538 | 072522 | | 097951 |
| 077456 | STB60S | 2 | 53 | 70.8 | 1161.2 | 072538 | 072522 | 097966 | 097955 |

MAXIMUM WIRE FILL

| | | 1 1/4" | 1 1/2" | 2" | 2 1/2" | 3" | 3 1/2" | 4" |
|---|---|--------|---------|---------|---------|---------|---------|---------|
| | | (35) | (41) | (53) | (63) | (78) | (91) | (103) |
| MAX. WIRE FILL #6 AWG CONDUCTORS OR SMALLER | U | 2.550" | 2.720" | 4.000" | 5.000" | 5.000" | 5.750" | 5.750" |
| | | (64.8) | (69.1) | (101.6) | (127.0) | (127.0) | (146.1) | (146.1) |
| | M | #3 | #2 | #1 | #2 /0 | #2 /0 | #4 /0 | #4 /0 |
| | D | 2.680" | 3.315" | 4.250" | 5.125" | 5.125" | 6.250" | 6.250" |
| | | (68.1) | (108.0) | (107.9) | (130.2) | (130.2) | (158.8) | (158.8) |

U UL514 INVESTIGATION OF CONDUIT BODIES FOR THREE CONDUCTOR INSTALLATION WITH NO INVESTIGATION
M MAXIMUM WIRE FILL MARKED ON CONDUIT BODY
D DISTANCE BETWEEN HUBS ON CONDUIT BODY