

## ORDERING INFORMATION

Order code: 62938  
 Description: BHPS0150/QUADTAP/C/HX/H/K/STD  
 UPC: 69549629387



## SPECIFICATIONS

Ballast type: Magnetic high pressure sodium  
 Ballast style: Core and coil  
 Circuit type: HX-HPF  
 ANSI code: S55  
 Input voltage (V): 120/208/240/277  
 Input frequency (Hz): 60  
 Line volt regulation: 10 %  
 Line watt regulation: Within trapezoid  
 Insulation class: H (180)

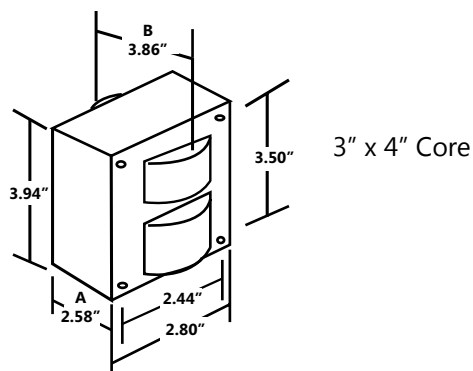

Input voltage (V)	Operating current (A)	Open circuit current (A)	Starting current (A)	Rated lamp watts (W)	Input watts (W)	OCV (V)	Dropout voltage (V)	UL 1029 code	Fuse rating (A)	Input current (A)	Power factor	Starting temperature
120	1.74	2.83	2.15	150	189	123	95	A	10	1.00 - 1.55	0.90	-40°F / -40°C
208	0.92	1.54	1.06	150	189	123	166	A	5	0.60 - 1.00	0.90	-40°F / -40°C
240	0.88	1.41	1.08	150	189	123	192	A	5	0.50 - 0.80	0.90	-40°F / -40°C
277	0.76	1.22	0.94	150	189	123	222	A	5	0.40 - 0.70	0.90	-40°F / -40°C

## HIGH POTENTIAL TEST (V)

1 minute:	2 000
2 seconds:	2 500
OCV test:	110 - 130
Short circuit:	3.60 - 4.60

## BALLAST DIMENSIONS

Dimension A:	2.58"
Dimension B:	3.86"
Lead lengths:	12" - 14"
Weight (lbs) :	7.49

## WIRING DIAGRAM

Ground ballast core

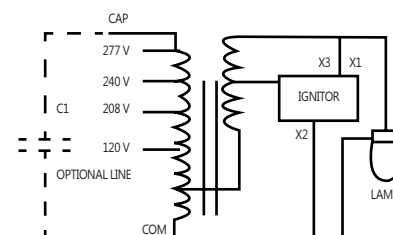

## BRACKET

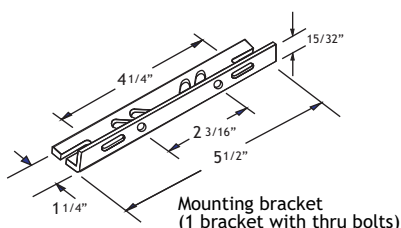

## CAPACITOR

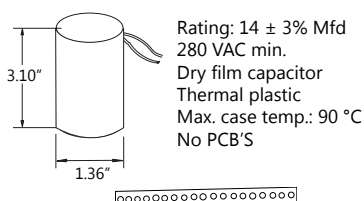

## IGNITOR

