

REV.	DATE	DESCRIPTION	ECO	BY	C'H'K.
A	6/15/2009 9:00:00 AM	NEW SALES DRAWING RELEASE	18356	IA	JG

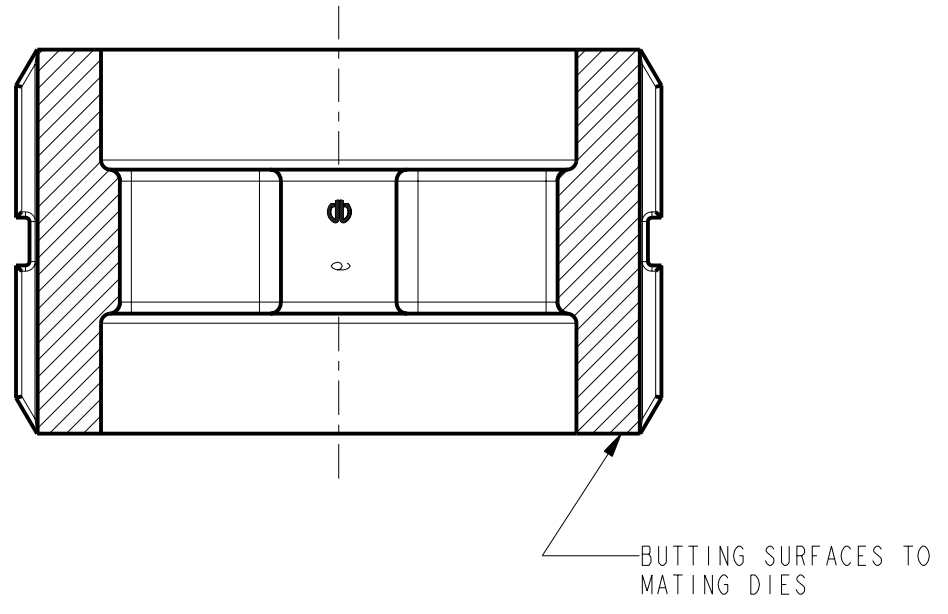
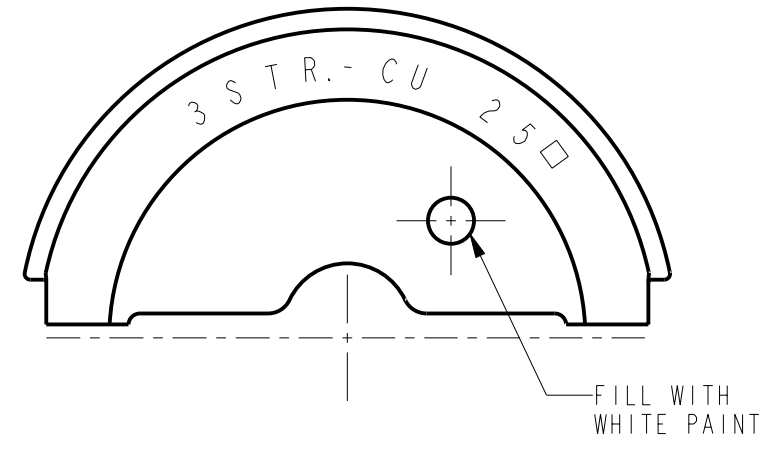
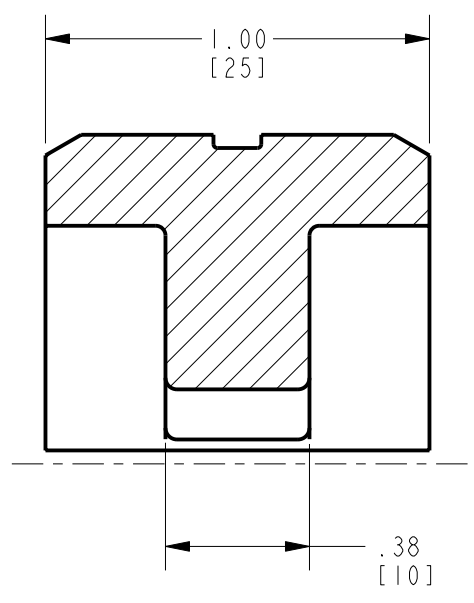
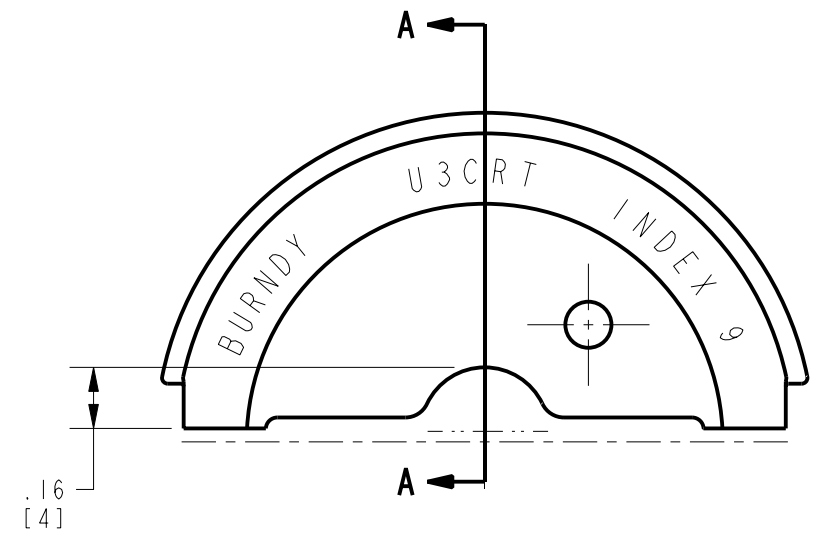

- NOTES:
1. DIMENSIONS IN BRACKETS [ ] ARE IN MILLIMETERS ROUNDED OFF TO THE NEAREST MILLIMETER, UNLESS OTHERWISE SPECIFIED, AND ARE FOR REFERENCE ONLY.
  2. DIE INSPECTION GAUGE CATALOG NUMBER (CUSTOMER & ENGINEERING USE ONLY): UPG-9.
  3. 4/0 STR. & SMALLER, THE SAME DIES WILL CRIMP CLASS "B" THRU "M" STRANDING.
  4. MATERIAL: STAINLESS STEEL.

TO ORDER BURNDY® PRODUCTS CALL  
 UNITED STATES:  
 1-800-346-4175 (LONDONDERRY, NH)  
 CANADA:  
 1-800-361-6975 (QUEBEC)  
 1-800-387-6487 (ALL OTHER PROVINCES)  
 FOR PRODUCT INFO: <http://www.burndy.com>

CIRCULAR BUTTING TWIN DIE		SCALE: 2:1
ITEM NO: 421348		DRAWING NO
CAT. NO: U3CRT		
DRAWN BY: I. ANBALAGAN	06/13/09	REV
CHECKER: --	--	
DSN APPVL: --	--	10102812
MFG APPVL: --	--	
QA APPVL: --	--	A
MKT APPVL: --	--	
PROD FAM: TOOLS-HYDRAULIC/U-DIES	SIZE	SHEET 1 OF 1
PROJECT #: --	B	
DOCUMENT TYPE: Sales		
REL LEVEL: Released		

REV: PE0200