

TWO-DOOR WITH FLOOR STANDS AND CLAMPS, TYPE 4

INDUSTRY STANDARDS

UL 508A Listed; Type 4, 12; File No. E61997
 cUL Listed per CSA C22.2 No. 94; Type 4, 12; File No. E61997

NEMA/EEMAC Type 3, Type 4, 12, 13
 CSA, File No. LR42186, Type 4, 12
 IEC 60529, IP66

APPLICATION

The Type 4 rating and polyester powder coating make these enclosures ideal for outdoor environments or food processing applications where it is necessary to protect controls and instrumentation from wet, non-corrosive environments. Featuring a continuous hinge with clamps, the enclosures are supported by floor stands that provide additional height and access for cleaning under the enclosure. Equipment can be mounted on either panels or racks.

SPECIFICATIONS

- 12 gauge steel
- Seams continuously welded and ground smooth; no holes or knockouts
- Body stiffeners for added strength
- Removable centerpost permits easy panel installation
- Panel supports
- Return flange around three sides of door and along top of enclosure opening channels away liquids and contaminants
- Stainless steel door clamps on three sides of each door assure water-tight seal
- Heavy gauge continuous hinge with stainless steel hinge pin
- Hasp and staple for padlock
- Data pocket is high-impact thermoplastic
- 12-in. floor stands welded to enclosure
- Heavy-duty lifting eyes
- Oil-resistant door gasket
- Collar studs provided for mounting optional panels
- Grounding stud on body
- Bonding provision on door
- Provision for mounting fluorescent light

FINISH

ANSI 61 gray polyester powder paint inside and out over pretreated surfaces. Optional panels have white or conductive finish.

ACCESSORIES

Panels
 PANELITE Enclosure Lights
 SPECTRACOOOL Indoor/Outdoor
 Enclosure Stabilizers
 Steel, Stainless Steel and Non-Metallic Window Kits
 Electric Heaters
 HOL-SEALERS Hole Seals
 INTERSAFE Data Interface Ports, Type 4/4X/12

MODIFICATION AND CUSTOMIZATION

Hoffman excels at modifying and customizing products to your specifications. Contact your local Hoffman sales office or distributor for complete information.

BULLETIN: A4L

Standard Product

Catalog Number	AxBxC in./mm	Panel	Conductive Panel	Panel Size D x E in./mm	Body Stiffener S in./mm	Number of Clamps
A62H48CLP	62.06 x 48.06 x 10.06	A60P48	A60P48G	15.00	15	16
	1576 x 1221 x 256			381	381	
A62H60DLP	62.06 x 60.06 x 12.06	A60P60	A60P60G	21.00	21	16
	1576 x 1526 x 306			533	533	
A74H60DULP	74.06 x 60.06 x 12.06	A72P60	A72P60G	21.00	21	18
	1881 x 1526 x 306			533	533	
A74H72DULP	74.06 x 72.06 x 12.06	A72P72	A72P72G	24.00	24	18
	1881 x 1830 x 306			610	610	
A74H72JULP	74.06 x 72.06 x 24.06	A72P72	A72P72G	24.00	24	18
	1881 x 1830 x 611			610	610	

Purchase panels separately

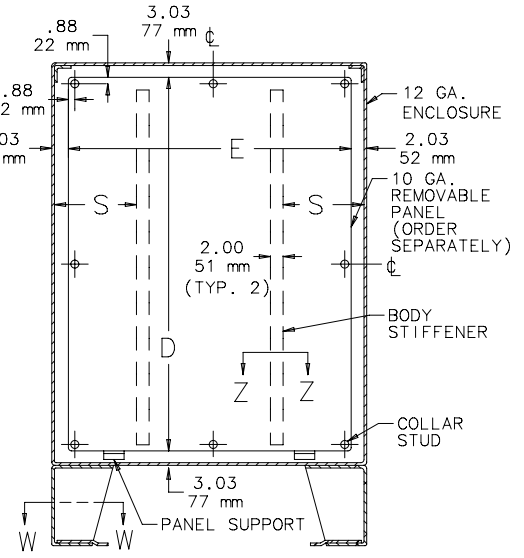
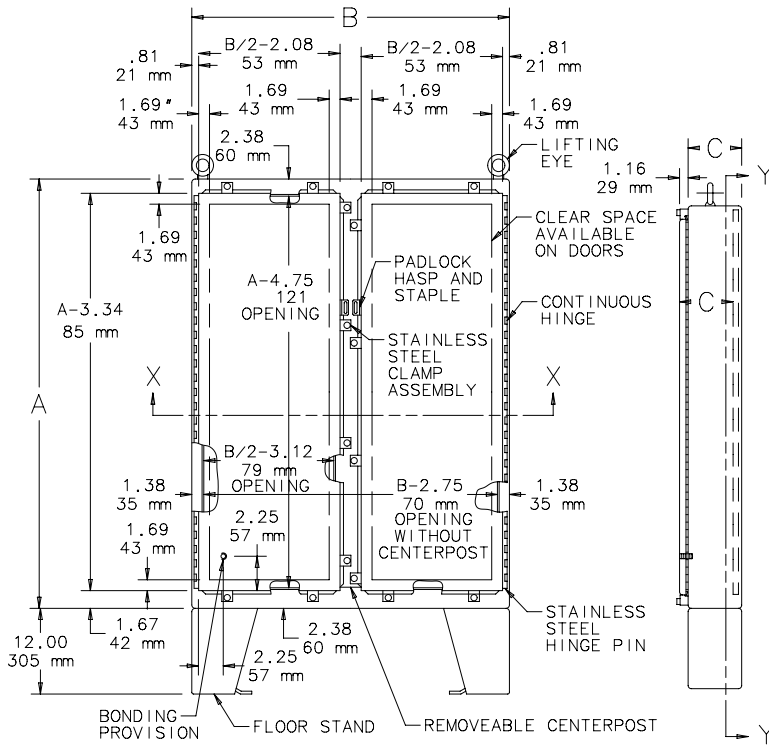

SECTION Y-Y

NOTE: Right door has removable 12.00 x 12.00 (305mm x 305mm) data pocket.

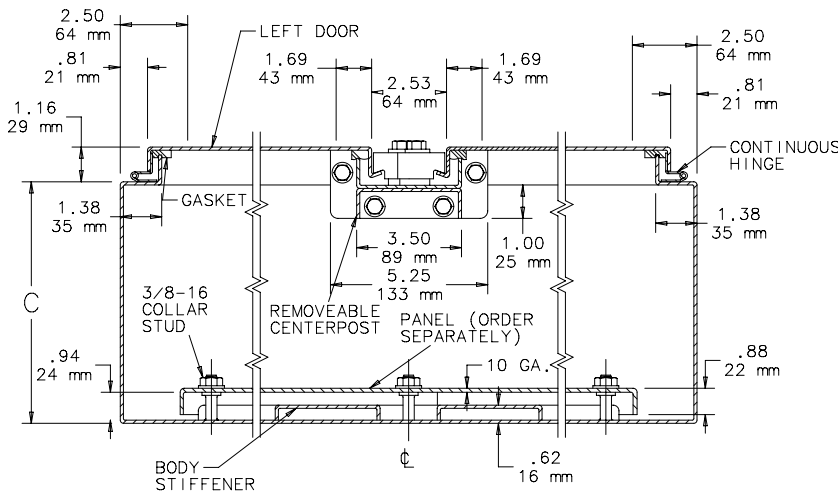

SECTION X-X
(LIFTING ANGLES NOT SHOWN)

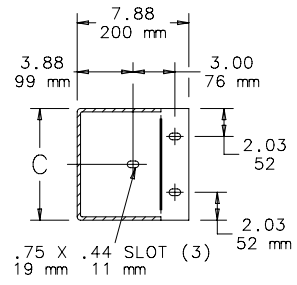

SECTION W-W

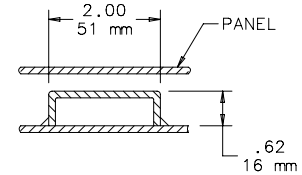

SECTION Z-Z

C2486-C