



Insulated Equipment Ground Kit

Cat. No. EGS 12/EGC12 for ReliaGear® Lighting Panelboard
Type RQ, RL and RE

Mounting Instructions

1. Put barrier in place before mounting kit.
2. Mount kit in holes in panelboard backwall using two #10 thread forming screws provided.
3. Remove paper backing from the enclosed identification label and place it in front of and adjacent to ground bar barrier.

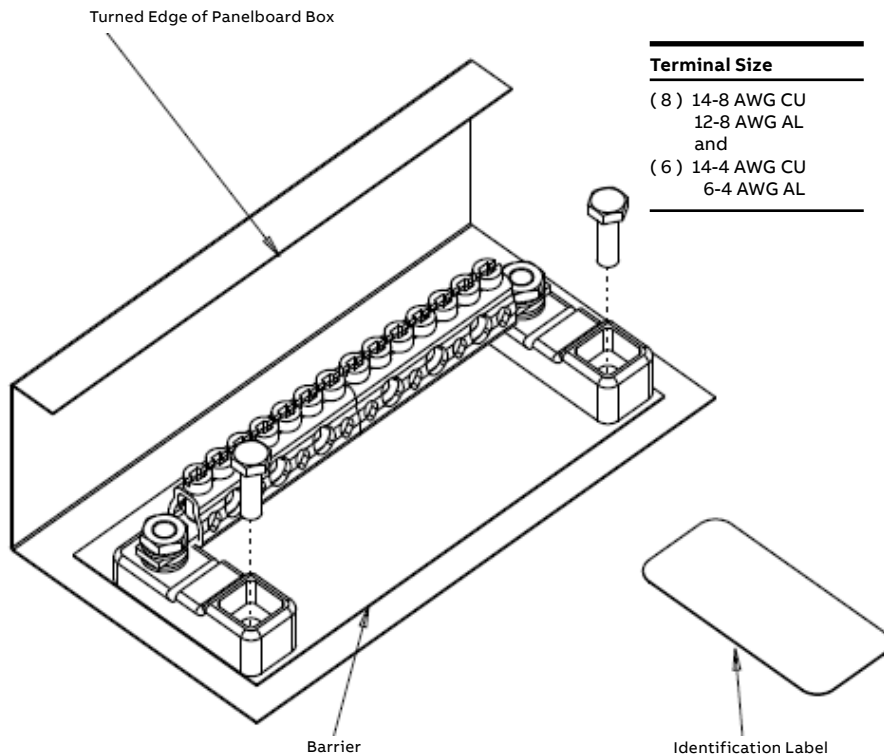

ABB Inc.
305 Gregson Drive
Cary, NC 27511

©Copyright 2020 ABB. All rights reserved.
Information provided is subject to change without notice. Please verify all details with ABB. All values are design or typical values when measured under laboratory conditions, and ABB makes no warranty or guarantee, express or implied, that such performance will be obtained under end-use conditions.
ReliaGear is a registered trademarks of ABB Inc.
GE is a registered trademark used under license from General Electric company.