

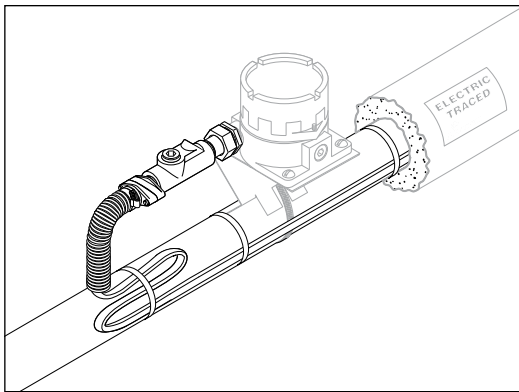

RAYCHEM

HAK-C-100

Connection Kit for Division 1 Hazardous Locations Installation Instructions



DESCRIPTION

The nVent RAYCHEM HAK-C-100 is a connection kit designed for use in Division 1 hazardous locations. The kit is for use only with the following heating nVent RAYCHEM industrial heating cables: BTV, HBTV, QTVR, HQTV, XTV, HXTV, LBTV2, HTV, FHP and VPL (-CT versions). Do not use this kit with any other heating cables. The kit contains materials for sealing one heating cable entry when making a power, splice, tee, or end termination. A heat-shrinkable core seal is provided specifically for use with LBTV2-CT heating cables. For all other heating cables, a CS-100 cold-applied core seal is provided.

Refer to the Heat-Tracing Systems Design and Installation Guide for Hazardous Div. 1 Locations (H56075) for assistance in the design of each heat-trace system. For technical support call nVent at (800) 545-6258.

APPROVALS

Hazardous Locations



⁽¹⁾ Class I, Div. 1, Groups B, C, D
Class II, Div. 1, Groups E, F, G
Class III



⁽³⁾ Class I Division 1 (Zone 1*),
Groups B, C, D
Class I Zone 1 IIC
Class II/III Division 1 (Zone 21*)
Groups E, F, G
Zone 21 IIC * Per CE Code
Table 18.

⁽¹⁾ HBTV, HQTV, HXTV and FHP only

⁽²⁾ Except HBTV, HQTV, HXTV, HTV and FHP

⁽³⁾ For HTV-CT only

TOOLS REQUIRED

- 1/2 in drive ratchet
- Marking pen
- Diagonal cutters
- Utility knife
- Needle nose pliers
- 5/16 in hex key
- 3/16 in slotted screwdriver
- Ruler
- 1/4 in hex key
- Pipe wrenches (2 required)
- 1/16 in hex key
- Wire strippers (for VPL only)
- 2500 Vdc Insulation Resistance Tester
- Heat gun or minitorch (required if heat-shrinkable core seal is used)

KIT CONTENTS

Item	Qty	Description
A	1	HAK sub-assembly: sealing fitting, nipple, and plugs
B	1	Union
C	1	Packing fiber
D	1	Sealing compound
E	1	Tubing clamp
F	1	Compression gland with screws
G	1	Compression gland with threaded inserts
H	5	Grommets (B, C, E, K, R)
I	1	Flex tube
J	1	Terminal block (max: 6 AWG wire)
K	2	Black heat-shrinkable tubes
L	1	Clear yellow heat-shrinkable tube
M	1	Green/yellow tube
N	1	CS-100 core sealer

ADDITIONAL MATERIALS REQUIRED

- Junction box: nVent RAYCHEM HAK-JB3-100 or agency-approved Division 1 hazardous location 3/4 in NPT junction box. Junction boxes other than the HAK-JB3-100 may not be compatible with the nVent RAYCHEM universal mounting bracket.
- Small volume of water
- Universal mounting bracket (UMB)—one per junction box
- Pipe strap—one per mounting bracket

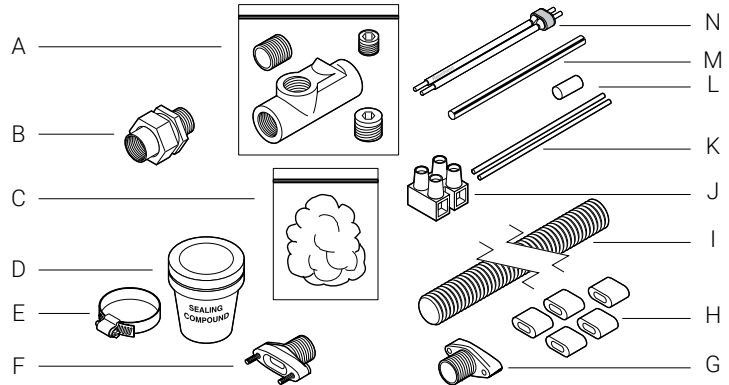

⚠ WARNING:

This component is an electrical device that must be installed correctly to ensure proper operation and to prevent shock or fire. Read these important warnings and carefully follow all of the installation instructions.

- To minimize the danger of fire from sustained electrical arcing if the heating cable is damaged or improperly installed, and to comply with nVent requirements, agency certifications, and national electrical codes, ground-fault equipment protection must be used. Arcing may not be stopped by conventional circuit breakers.
- Component approvals and performance are based on the use of nVent-specified parts only. Do not substitute parts or use vinyl electrical tape.

- Keep components and heating cable ends dry before and during installation.
- The black heating cable core and fibers are conductive and can short. They must be properly insulated and kept dry.
- Damaged bus wires can overheat or short. Do not break bus wire strands when scoring the jacket or core.
- Use only fire-resistant insulation materials, such as fiberglass wrap or flame-retardant foam.
- Heat-damaged components can short. Use a heat gun or a torch with a soft, yellow, low-heat flame. Keep the flame moving to avoid overheating, blistering, or charring the heat-shrinkable tubes. Avoid heating other components. Replace any damaged parts.

⚠ CAUTION:

HEALTH HAZARD: Prolonged or repeated contact with the sealant in the core sealer may cause eye or skin irritation. Wash hands thoroughly. Overheating or burning the sealant will produce fumes that may cause polymer fume fever. Avoid contamination of cigarettes or tobacco. Consult MSDS VEN 0058 for further information.

Overheating heat-shrinkable tubes will produce fumes that may cause irritation. Use adequate ventilation and avoid charring or burning. Consult MSDS RAY3122 for further information.

CHEMTREC 24-hour emergency telephone:
(800) 424-9300

Non-emergency health and safety information:
(800) 545-6258.

⚠ AVERTISSEMENT:

Ce composant électrique doit être installé correctement pour éviter les risques d'incendie ou de chocs électriques. Lire ces avertissements importants et suivre attentivement toutes les instructions d'installation.

- Pour réduire le danger d'incendie causé par un arc électrique entretenu, si le câble chauffant est endommagé ou mal installé, et pour respecter les exigences de nVent et celles des codes applicables, il est impératif d'utiliser une protection par disjoncteur différentiel. Les disjoncteurs ordinaires ne sont pas toujours capables de supprimer les arcs électriques.
- Les approbations et les performances des composants sont basées sur l'utilisation des pièces nVent spécifiées seulement. N'utilisez pas de pièces de rechange ou de ruban isolant en vinyle.

- Le noyau et les fibres du câble chauffant noir sont conducteurs et peuvent provoquer un court-circuit. Ils doivent être correctement isolés et gardés à sec.
- Les fils omnibus endommagés peuvent surchauffer ou subir un court-circuit.
- Ne brisez jamais les fils omnibus lorsque vous incisez la gaine ou le noyau.
- Maintenez les composants et les extrémités des câbles chauffants secs avant et pendant l'installation.
- Les fils omnibus peuvent provoquer un court-circuit s'ils se touchent. Les garder à l'écart les uns des autres.
- N'utilisez que des matériaux isolants ininflammables, par exemple une gaine de fibre de verre ou de la mousse ignifuge.
- Laissez ces instructions d'installation à l'utilisateur pour qu'il puisse les consulter.

⚠ MISE EN GARDE:

DANGER POUR LA SANTÉ : Le contact prolongé ou répété avec le produit d'étanchéité du noyau peut provoquer une irritation de la peau. Lavez-vous les mains soigneusement. La surchauffe et la combustion du produit d'étanchéité produira des vapeurs qui peuvent causer la fièvre des vapeurs de polymères. Évitez la contamination des cigarettes ou du tabac.

Consultez la fiche technique santé-sécurité (FTSS) VEN 0058 pour obtenir de plus amples informations.

Téléphone en cas d'urgence 24 heures sur 24 de CHEMTREC :
(800) 424-9300

Renseignements non urgents en matière de santé et de sécurité : (800) 545-6258

General Instructions

- The HAK-C-100 connection kit is for use only with the following heating cables: BTV, HBTV, QTVR, HQTV, XTV, HXTV, LBTV2, HTV, FHP and VPL (-CT versions). Do not use this kit with any other heating cables.
- Select correct grommet from table on right. The grommet I.D. letter is embossed on each grommet.

GROMMET SELECTION

Heating Cable for FM Only	Grommet	Heating Cable for FM Only	Grommet	Heating Cable for FM Only	Grommet
5HBTV1-CT	B	15HXTV1-CT	R	20QTVR1-CT	E
5HBTV2-CT	B	15HXTV2-CT	R	20QTVR2-CT	E
8HBTV-1-CT	E	20HXTV1-CT	R	All XTV1-CT-T3	R
8HBTV-2-CT	E	20HXTV2-CT	R	All XTV2-CT-T3	R
10HBTV1-CT	E	FHP-2	E	All XTV1-CT-T2	R
10HBTV2-CT	E	FHP-3	C	All XTV2-CT-T2	R
12HQTV1-CT	C	5BTV1-CT	B	All HTV-CT	R
12HQTV2-CT	C	5BTV2-CT	B	All VPL1-CT	R
20HQTV1-CT	E	8BTV-1-CT	E	All VPL2-CT	R
20HQTV2-CT	E	8BTV-2-CT	E	LBTV2-CT	K
5HXTV1-CT	R	10BTV1-CT	E		
5HXTV2-CT	R	10BTV2-CT	E		
10HXTV1-CT	R	10QTVR1-CT C	C		
10HXTV2-CT	R	10QTVR2-CT C	C		

⚠ WARNING: Reusing the grommet or using the wrong grommet can cause leaks, cracked components, shock, or fire. Be sure the grommet you select is correct for the heating cable you plan to install. Use a new grommet whenever the heating cable has been pulled out of the termination.

⚠ Avertissement: Réutiliser un passe-fil ou utiliser le mauvais passe-fil peut entraîner des fuites, la fissuration des composants, l'électrocution ou un incendie. Assurez-vous toujours que le passe-fil sélectionné est celui correspondant au câble chauffant qui est installé. Utilisez toujours un nouveau passe-fil lorsque le câble chauffant a été retiré de la terminaison (passe-fil)

1

- Fasten the nVent RAYCHEM universal mounting bracket (UMB) or suitable mounting plate for another junction box to the pipe at the desired location. Be sure the pipe strap is under the heating cable.

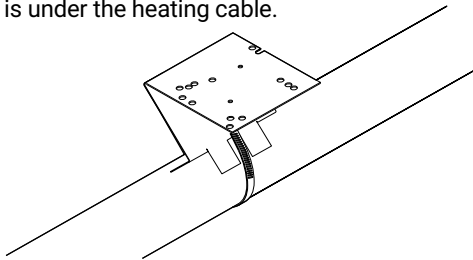

2

- Thread compression gland with threaded inserts into fitting until tight.
- Thread nipple into female half of union until tight.
- Thread nipple into sealing fitting until tight.

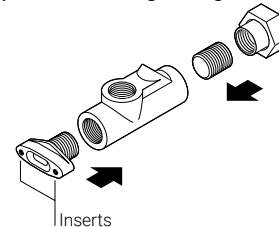

3

- Mount box on bracket.
- Thread male half of union into box entry.
- Assemble union halves together.

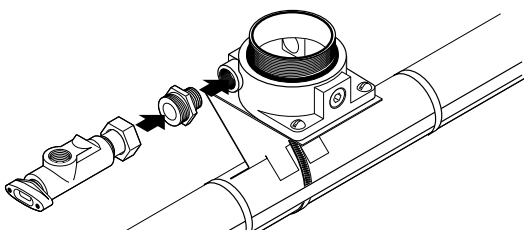

4

- Measure flex tube and cut to length from gland to pipe.

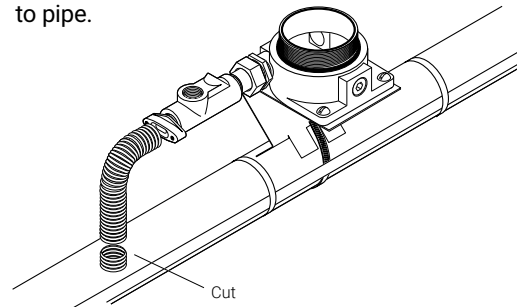

5

- Select correct grommet from table on page 3.
- Slide parts onto heating cable as shown.
- Slide heating cable through fittings and box.
- Repeat steps 2 through 5 for each additional heating cable.

Important
For VPL-CT only:
Locate indentation
(bus wire connection)
at this point

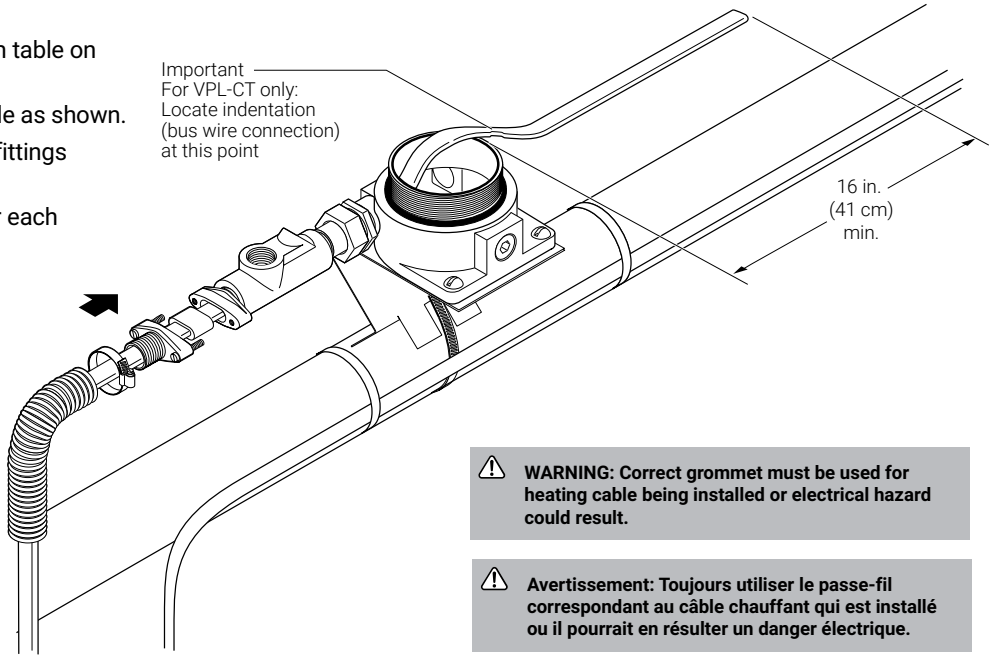

⚠ **WARNING:** Correct grommet must be used for heating cable being installed or electrical hazard could result.

⚠ **Avertissement:** Toujours utiliser le passe-fil correspondant au câble chauffant qui est installé ou il pourrait en résulter un danger électrique.

6A

For BTV-CT, HBTV-CT, QTVR-CT, HQTV-CT, FHP, XTV-CT, HXTV-CT, HTV-CT, and LBTV2-CT heating cables

- Lightly score outer jacket as shown.
- Bend heating cable to break jacket at score, then peel off jacket.

Go to step 7.

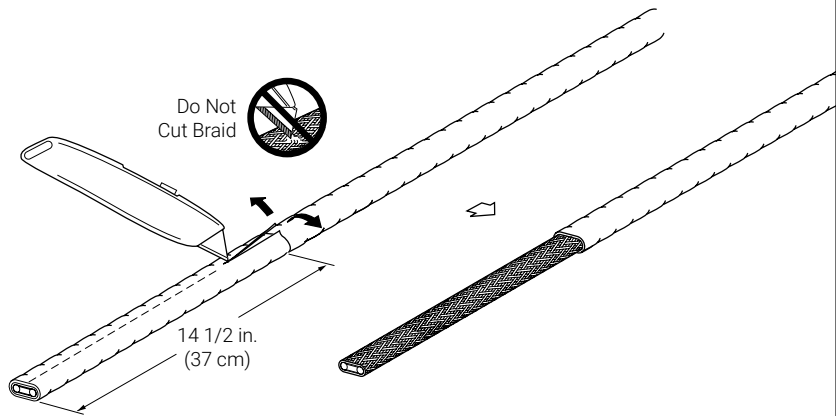

6B

For VPL-CT heating cables

- Cut heating cable 15 in. (38 cm) from the indentation (bus wire connection).
- Lightly score outer jacket as shown.
- Bend heating cable to break jacket at score, then peel off jacket.

Go to step 7.

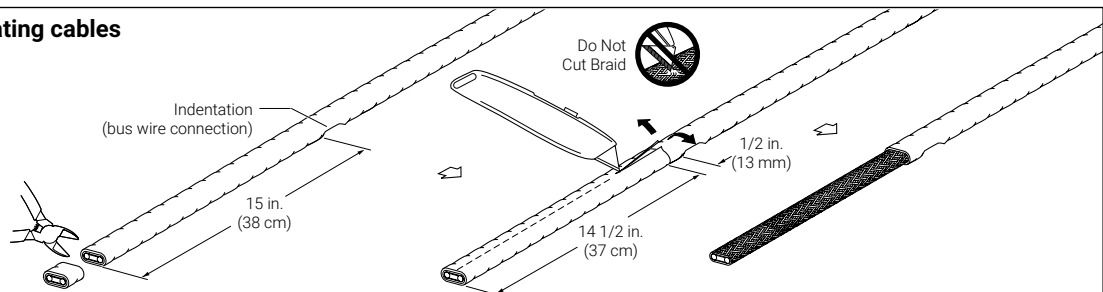

7 For VPL-CT only:

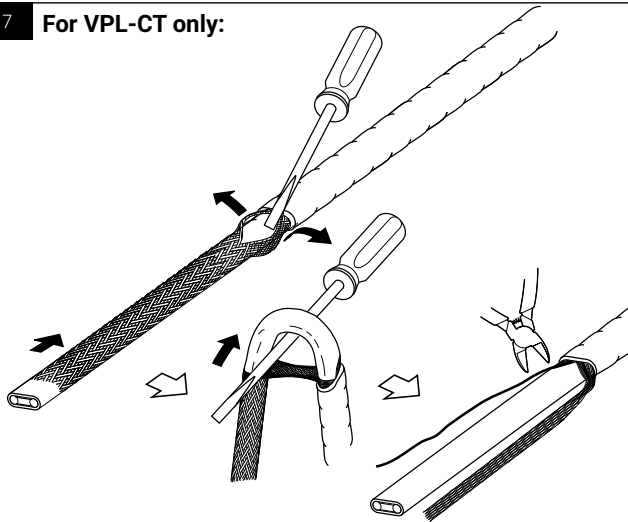

- Push braid back to create a pucker.
- At pucker use a screwdriver to open braid
- Bend heating cable and work it through opening in braid.
- For VPL-CT only: Cut and remove thread.

8

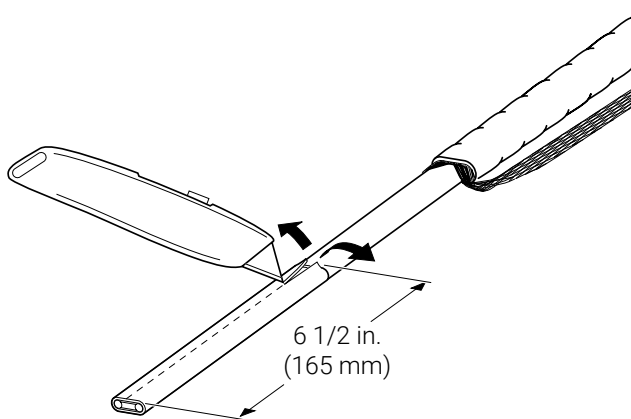

- Lightly score inner jacket around and down as shown.
- Bend heating cable to break jacket at score, then peel off jacket.

9A For XTV-CT and HXTV-CT heating cables

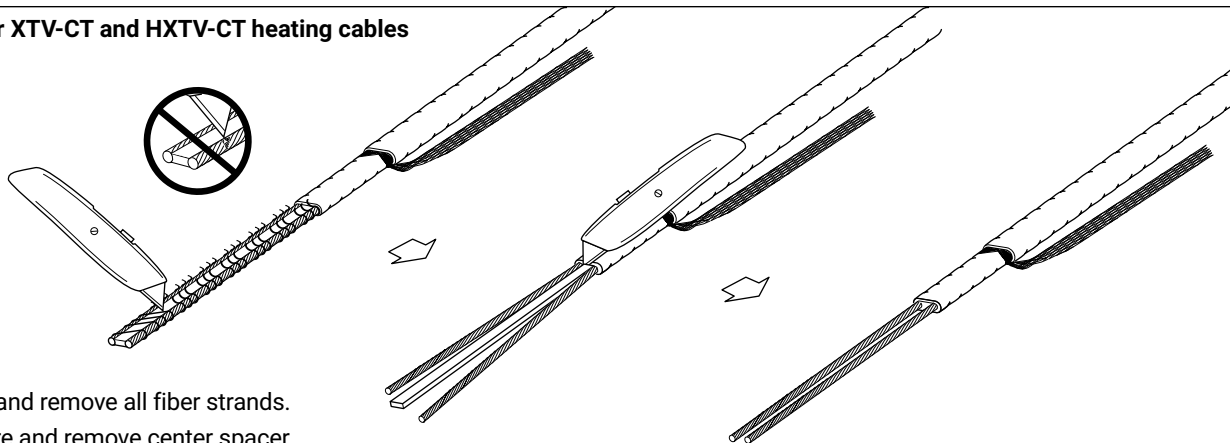

- Cut and remove all fiber strands.
- Score and remove center spacer.
- Remove any remaining core material.

Go to step 10.

9B For BTV-CT, HBTV-CT, QTVR-CT, HQTV-CT, FHP and LBTV2-CT heating cables

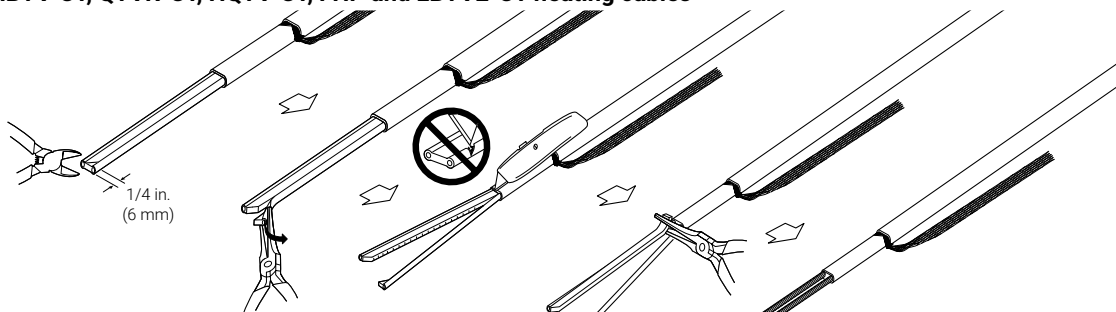

- Notch core.
- Peel bus wire from core.
- Score between bus wires at inner jacket.
- Bend and snap core.
- Peel core from bus wire.
- Remove any remaining core material.

For LBTV2-CT go to Step A on page 11.

For all other heating cables go to step 10.

9C For HTV-CT heating cables

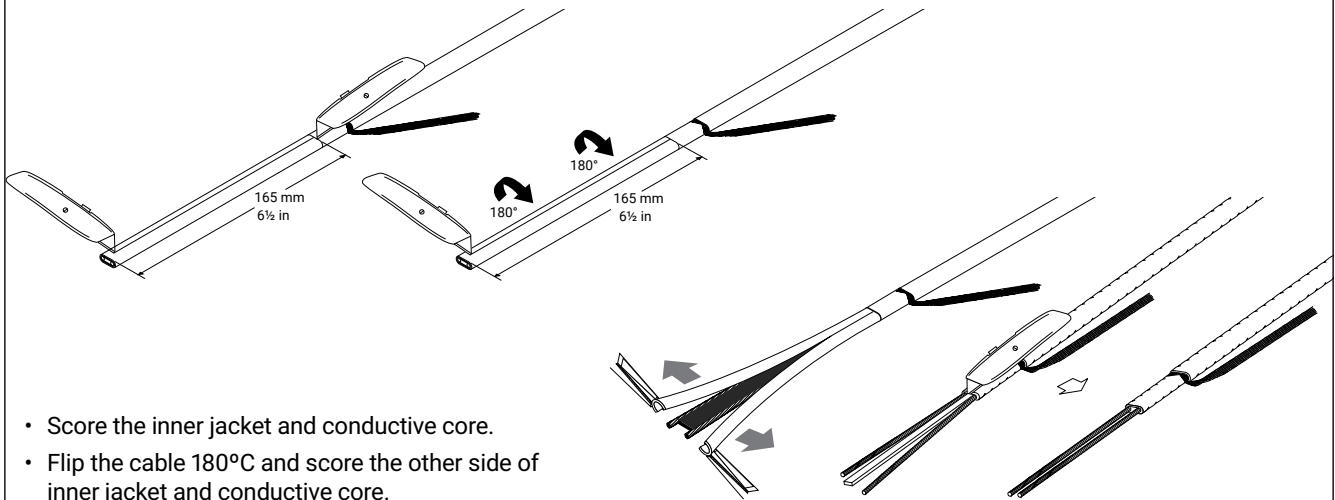

- Score the inner jacket and conductive core.
- Flip the cable 180° and score the other side of inner jacket and conductive core.
- Remove the inner jacket, conductive core by using needle-nose pliers.
- Score and remove center insulation
- Remove any remaining core material

9D For VPL-CT heating cables

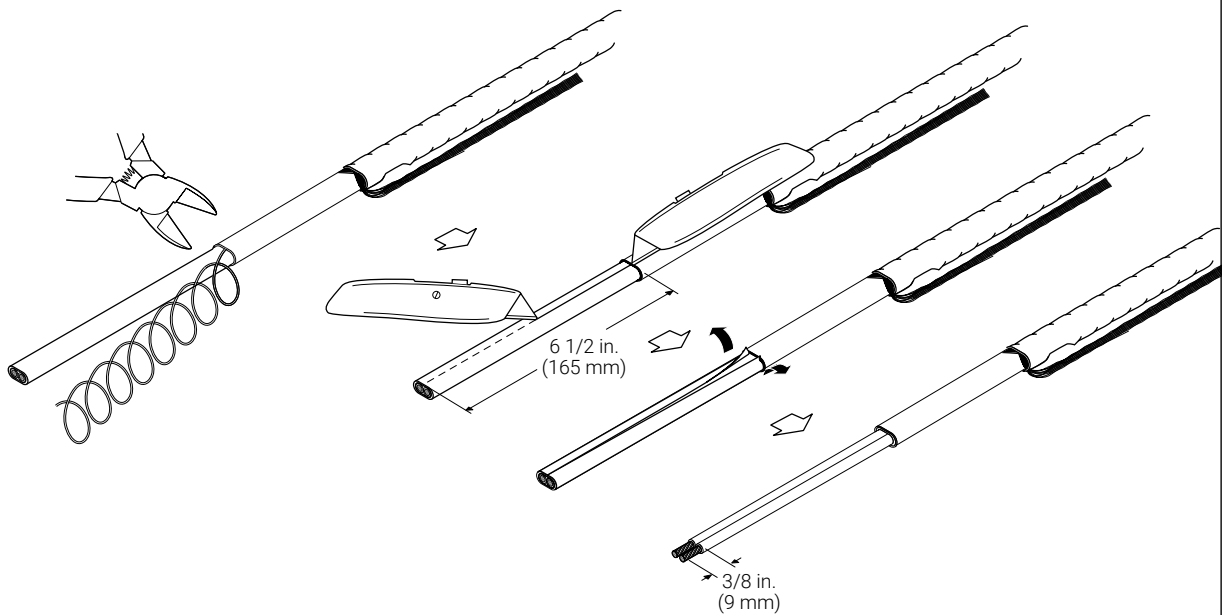

- Unwind heating element, cut and remove as shown.
- Lightly score clear jacket around and down as shown.
- Bend heating cable to break jacket at the score then peel off jacket.
- Remove 3/8 in. (9 mm) insulation from bus wires.

10

- Mark both sides of jacket 5/8 in. (15 mm) as shown. For VPL-CT go to Step 11. For all other heating cables go to Step 12.

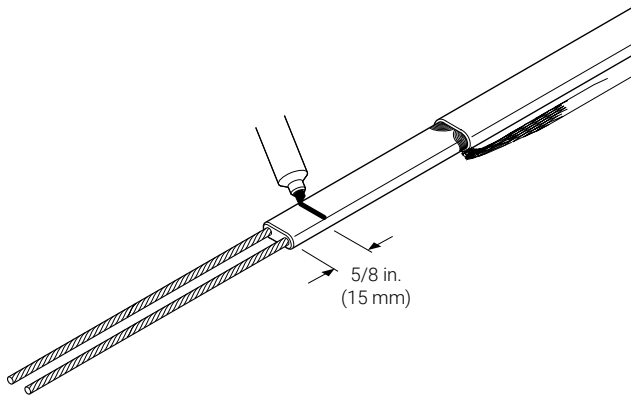

11

For VPL-CT only

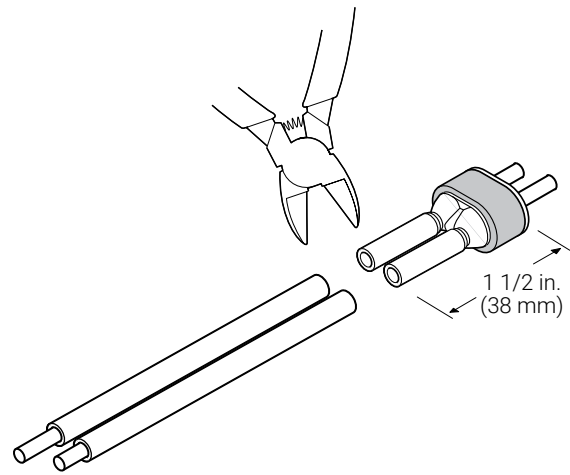

- Cut off and discard end of core sealer legs.

12

- Refer to material safety data sheet RAY5510.
- If needed, retwist and straighten bus wires.
- Insert bus wires into guide tubes as shown.
- Make sure all strands go into tubes.

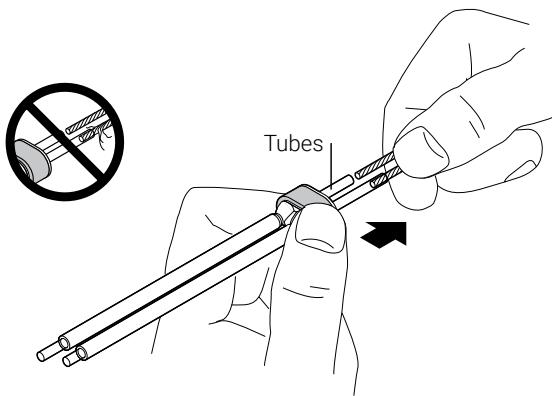

13

- Push core sealer onto the heating cable to the mark made in Step 10.
- Note: Extra force may be required for larger cables.

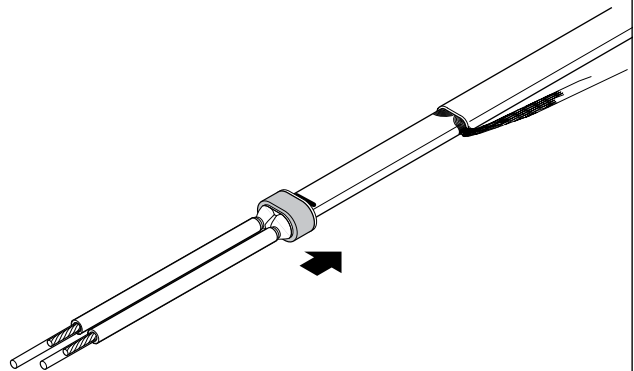

14

- Remove the tubes and dispose of them in a plastic bag.

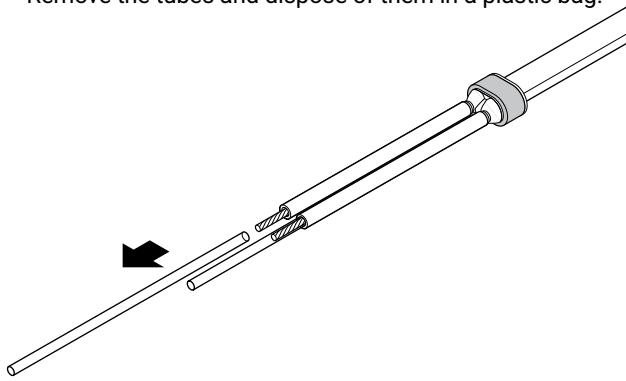

15

- Trim bus wires (except VPL-CT).
- Trim braid.
- Slip the green/yellow tube onto the braid.

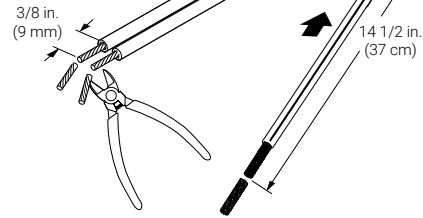

16A

Heating Cable Test 1

Following the test method outlined below, perform an insulation resistance test on the heating cable using a 2500 Vdc tester.

Test Method

- Perform Tests A and B at 500, 1000, and 2500 Vdc.
- Insulation resistance criteria is defined in Step 16b (page 7).
- If the readings vary with the voltage refer to the Troubleshooting Guide (page 12).

Test A - - - - -

- Connect the test leads as shown.
- Measure the insulation resistance between the heating cable bus wires and the braid.
- Record the Test A insulation resistance values in the "Heating Cable Test 1" section of the FM Required Division 1 Installation Record on page 14.

Test B ———

- Connect the test leads as shown.
- Measure the insulation resistance between the braid and the metal pipe.

IMPORTANT:

- Be sure to isolate the braid from the ground before performing Test B.
- To perform Test B after sealing compound is poured into sealing fitting (as braid may contact sealing fitting or junction box), see illustration in Post-Thermal-Insulation Heating Cable Test 2, Step 21, page 8.
- Record the Test B insulation resistance values in the "Heating Cable Test 1" section of the FM Required Division 1 Installation Record on page 14.

WARNING: Fire Hazard. Megohmmeter test can produce sparks. Be sure there are no flammable vapors in the area before performing this test. Follow all site safety guidelines when working in hazardous areas.

Avertissement: risque d'incendie. Le test d'isolation au megohmmètre peut produire des étincelles. Toujours s'assurer qu'il n'y a pas de vapeurs inflammables dans les environs avant d'effectuer ce test. Suivre toutes les consignes de sécurité du site lors du travail en zones dangereuses.

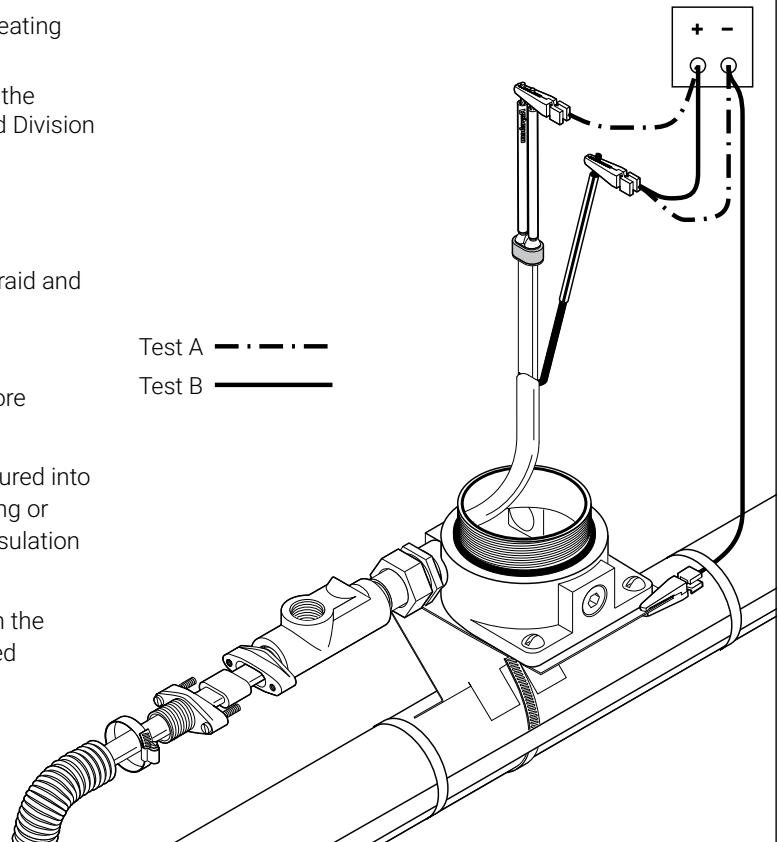

Insulation Resistance Criteria

A clean, dry, properly installed circuit should measure thousands of megohms, regardless of heating cable length or measuring voltage (0 to 2500 Vdc). The following criteria are provided to assist in determining acceptability of an installation where optimum conditions may not apply:

- All insulation resistance values should be greater than or equal to 1000 megohms.
- Insulation resistance values from Test A, for any particular circuit, should not vary more than 25% as a function of measuring voltage.
- Insulation resistance values from Test B, for any particular circuit, should not vary more than 25% as a function of measuring voltage.

If any of the above conditions is not met, consult the Troubleshooting Guide (page 12).

17

- Carefully pull heating cable back through box, making sure core sealer remains positioned at 5/8 in. (15 mm) mark. Continue pulling until end of outer jacket is centered in sealing fitting opening (see Step 18).

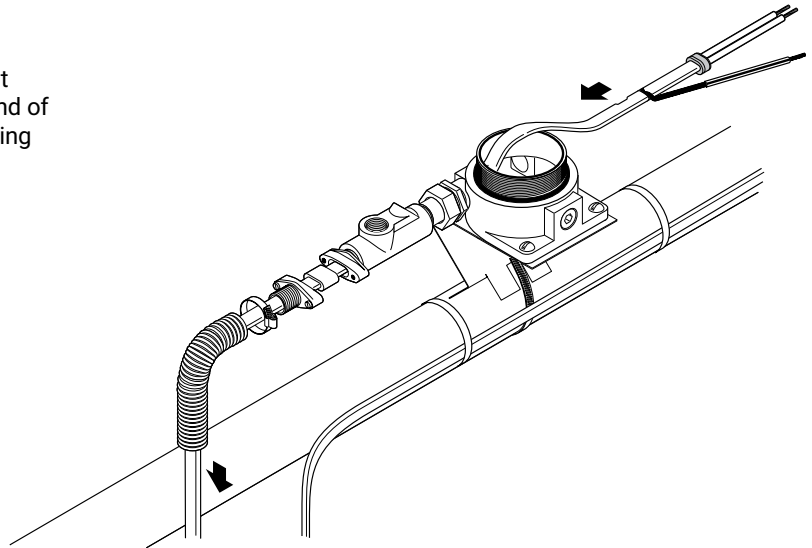

18

- Be sure green/yellow tubing does not extend into sealing fitting.
- Center heating cable as shown.

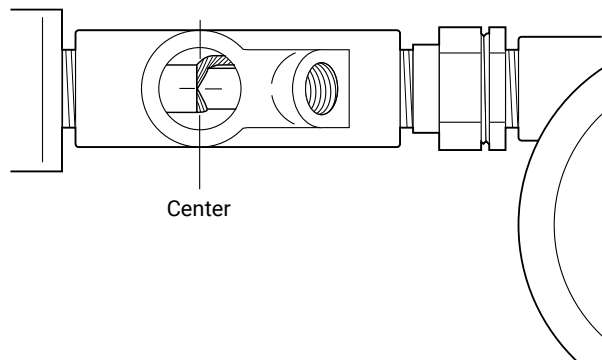

19

- Position grommet in gland cavity.
- Tighten compression gland screws, being careful not to change position of heating cable in sealing fitting (see Step 18).
- Install flex tubing onto compression gland.
- Tighten tubing clamp.

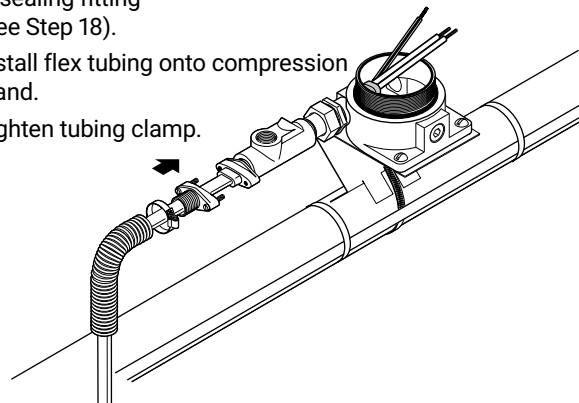

- Loop and tape extra heating cable to pipe.
- Apply insulation and cladding.

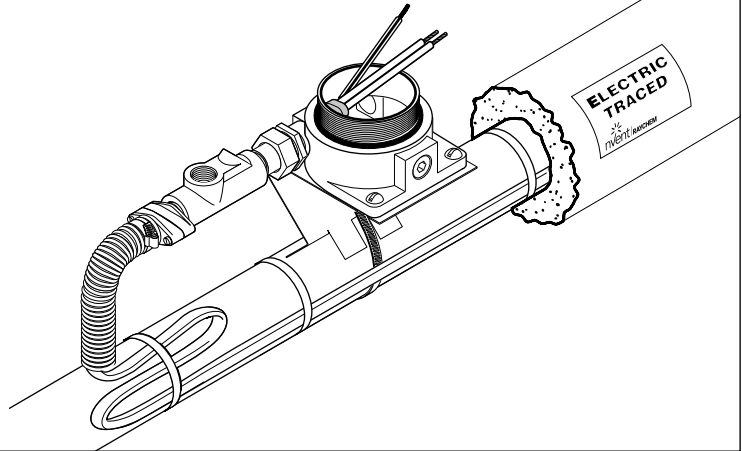

Post-Thermal-Insulation Heating Cable Test 2

Following the test method outlined below, perform an insulation resistance test on the heating cable using a 2500 Vdc tester.

- Disconnect union and carefully pull braid out of junction box. Do not pull heating cable and CS-100 core sealer out of junction box.
- Isolate sealing fitting and braid wire from junction box and pipe.

Test Method

- Perform Tests A and B at 500, 1000, and 2500 Vdc.
- Insulation resistance criteria is defined in Step 16b (page 7).
- If the readings vary with the voltage refer to the Troubleshooting Guide (page 12).

Test A - - - - -

- Connect the test leads as shown.
- Measure the insulation resistance between the heating cable bus wires and the braid.
- Record the Test A insulation resistance values in the "Post-Thermal-Insulation Heating Cable Test 2" section of the FM Required Division 1 Installation Record on page 14.

Test B ———

- Connect the test leads as shown.
- Measure the insulation resistance between the braid and the metal pipe.
- Record the Test B insulation resistance values in the "Post-Thermal-Insulation Heating Cable Test 2" section of the FM Required Division 1 Installation Record on page 14.
- Reinstall assembly in the junction box; be sure core sealer is fully installed over the end of the heating cable.

IMPORTANT:

Make sure the CS-100 core seal remains in position when pulling the heating cable braid wire out through the hub of the junction box.

WARNING: Fire Hazard. Megohmmeter test can produce sparks. Be sure there are no flammable vapors in the area before performing this test. Follow all site safety guidelines when working in hazardous areas.

Avertissement: risque d'incendie. Le test d'isolation au megohmmètre peut produire des étincelles. Toujours s'assurer qu'il n'y a pas de vapeurs inflammables dans les environs avant d'effectuer ce test. Suivre toutes les consignes de sécurité du site lors du travail en zones dangereuses.

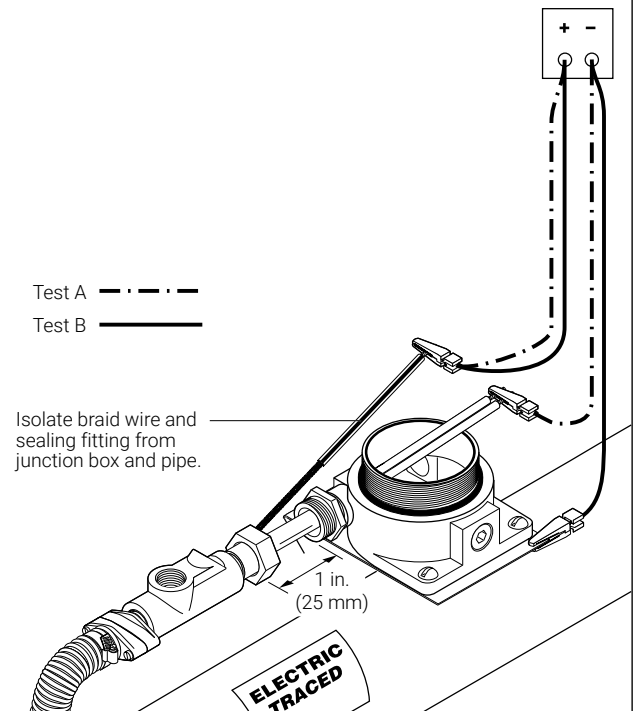

22

- Refer to material safety data sheet VEN0025.
- Pack fiber around heating cable as shown. Be careful not to damage cable.

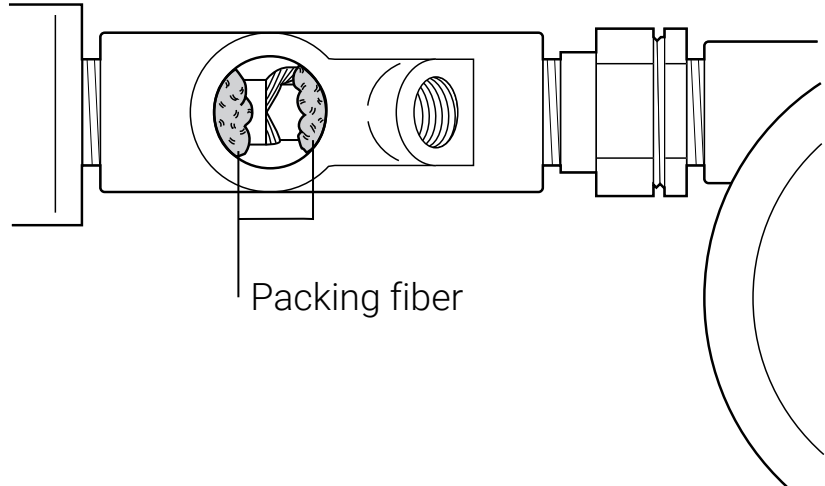

23

IMPORTANT: To ensure that the sealing compound sets properly, maintain a minimum ambient temperature of 32°F (0°C) for 8 hours after pouring into fitting.

- Refer to material safety data sheet VEN0024.
- Weather-seal the bracket and flexible tube entries.
- Mix sealing compound according to manufacturer's recommendation on container. Sealing mixture should be a pourable paste. Pour into sealing fitting.
- Install plugs.

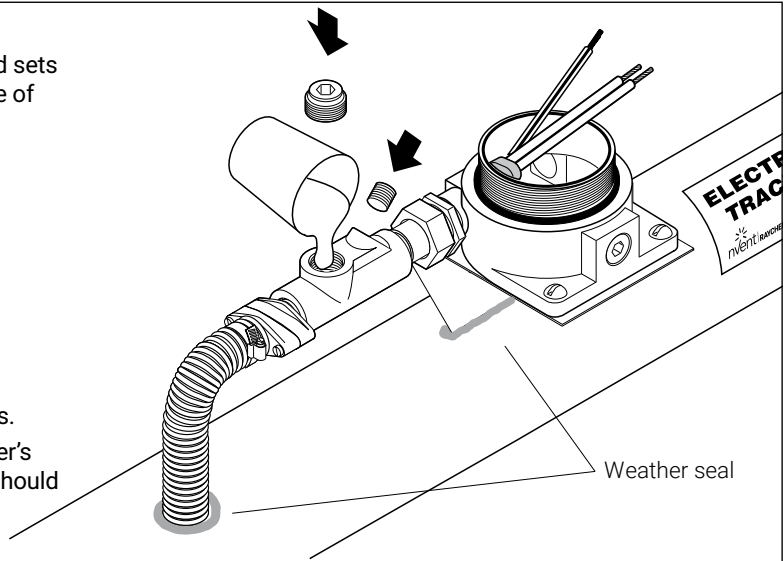

24

- Discard small loose screw packaged with grounding bar. Use larger green screw and washer supplied with HAK-JB3-100 junction box.

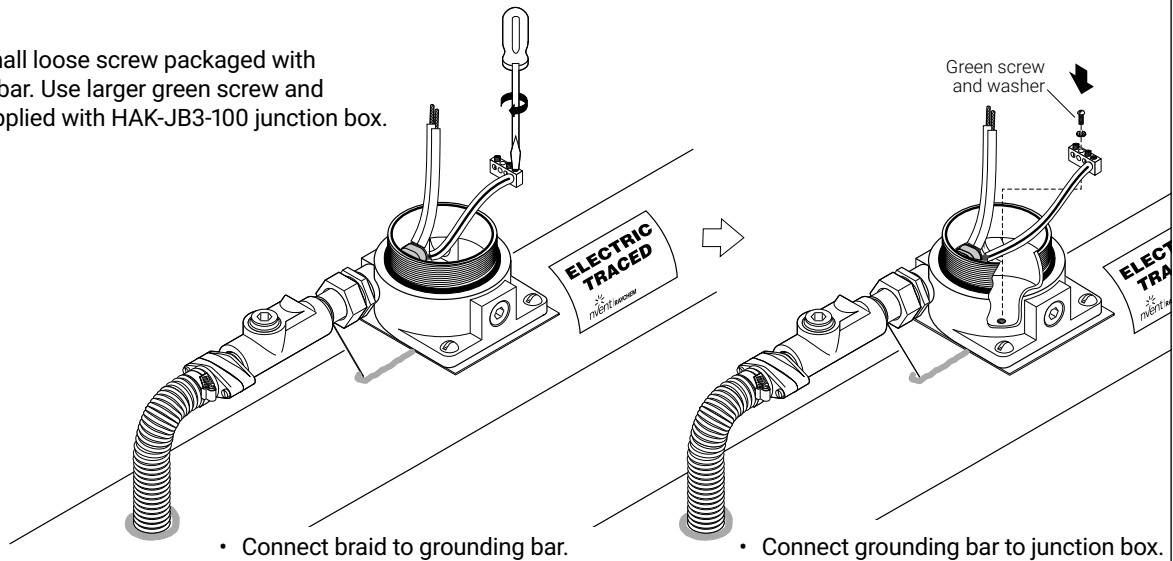

For power connections only:

- Install conduit and sealing fitting with drain.
- Pull in power and ground wires.



Make sure conductors are not exposed.

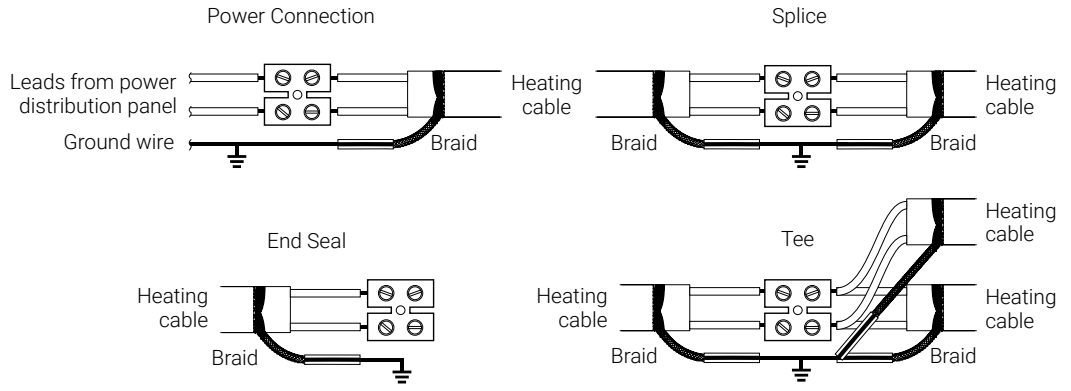

- **Make connections to terminal block (terminal block is installed "floating" in the junction box).**

For power connections only: Use agency-approved Class 1, Division 1 sealing fitting with drain valve (not supplied by nVent RAYCHEM).

- **Inspect each core seal for proper placement.**
- **Stow wires in box.**
- **Install cover and gasket.**
- **Tighten cover set screw.**

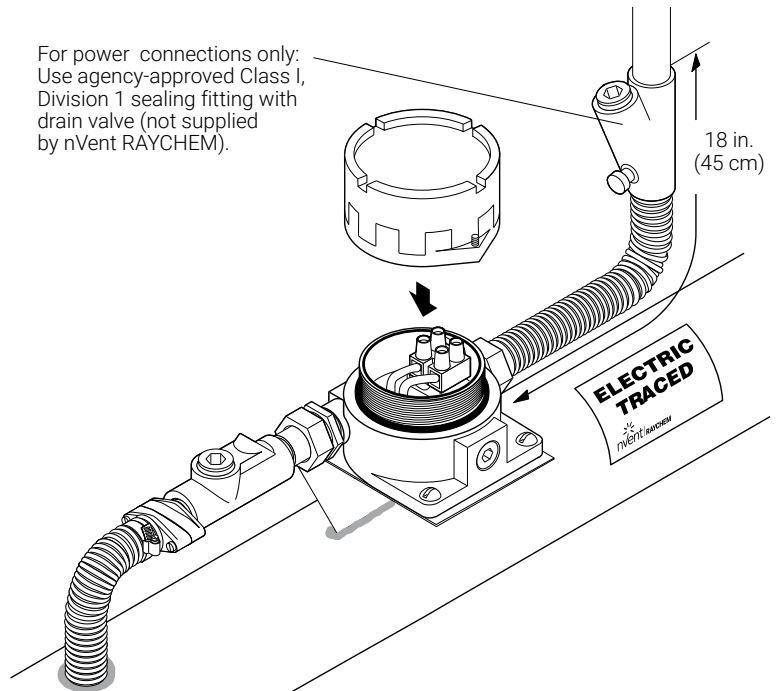

HEAT-SHRINKABLE CORE SEALER INSTALLATION INSTRUCTIONS

Use the heat-shrinkable core sealer with LBTV2-CT in place of the cold-applied core sealer shown in Step 12 on page 5.

A

⚠ WARNING: Fire Hazard. Heat guns or minitorches can cause fire or explosion in hazardous areas. Be sure there are no flammable materials or vapors in the area before using these tools. Follow all site safety guidelines when working in hazardous areas.

⚠ Avertissement: risque d'incendie. Les pistolets thermiques et torches miniatures peuvent déclencher un incendie ou une explosion dans les zones dangereuses. Toujours suivre les consignes de sécurité du site lors du travail en zone dangereuse.

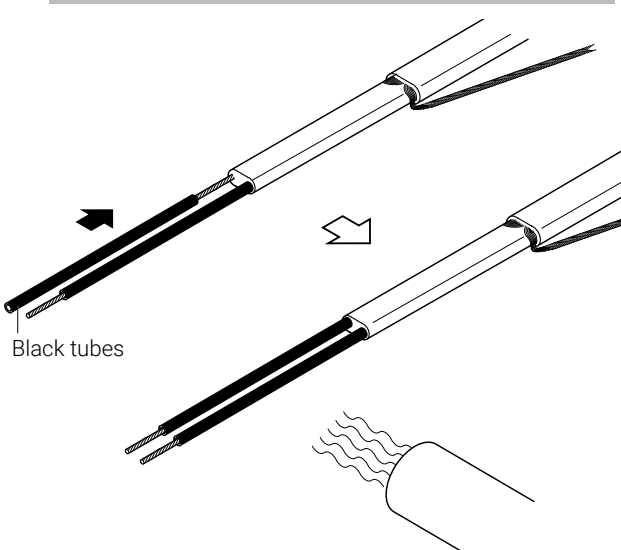

Black tubes

- Refer to material safety data sheet RAY3122.
- Slide on black heat-shrinkable tubes.
- Use heat gun or minitorch with soft yellow flame to gently heat tubes until they shrink.

B

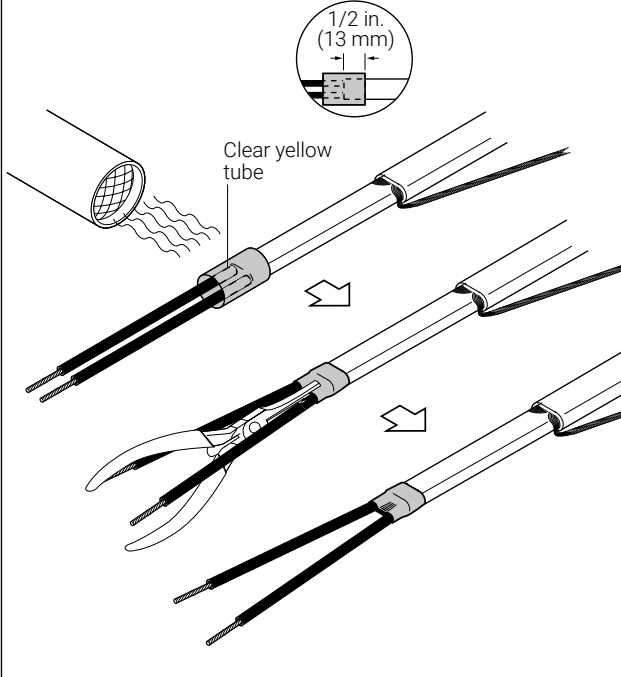

1/2 in. (13 mm)

Clear yellow tube

- Center clear yellow tube over end of inner jacket.
- Heat tube until it shrinks and adhesive flows out ends. While still hot, immediately pinch between bus wires and hold for 5 seconds to create a seal.
- Go to step 15 and continue with installation.

TROUBLESHOOTING GUIDE

Symptoms	Probable Causes	Correction
Insulation resistance is less than expected or varies with voltage (500, 1000, 2500 Vdc).	<p>Nicks or cuts in heating cable with or without moisture present.</p> <p>Short between braid and heating cable core or between braid and pipe.</p> <p>Crossed bus wires in core seal.</p>	Check all connections in power, splice, tee, and end seal kits for cuts in heating cable jackets, or for improper stripping distances. Restrip heating cable to remove damaged areas or establish proper distances. If heating cable is not yet insulated, visually inspect for damage, especially at elbows and flanges and around valves. If system is insulated, disconnect heating cable section between power kits, splices, etc., and test again to isolate damaged section of cable. Use nVent RAYCHEM DET-2200 fault locator or other appropriate device to locate fault. Replace damaged heating cable sections.
Meter needle oscillates rapidly or indicates charging and discharging.	Arcing created by damage to insulation or exposed electrical parts.	Same as above.
Insulation resistance increases slowly with time.	Moisture present between energized parts.	Check all connections in power, splice, tee, and end seal kits for signs of moisture. Dry out connections and retest. Be sure all conduit entries are sealed, and that condensate in conduit cannot enter power connection boxes. If no water is present in connections, isolate sections as described in correction outlined above. If heating cable core or bus wires are exposed to large quantities of water, replace heating cable. Drying the heating cable is not sufficient, as the power output of the heating cable may be significantly reduced.
Insulation resistance decreases rapidly during or after the charging period.	Heavily wetted surfaces between energized parts.	Same as above.
<p>Circuit breaker (GFPD) trips.</p> <p>⚠ WARNING: Fire Hazard. A tripped ground-fault breaker may mean the heating cable has been damaged or improperly installed and must not be ignored. Sustained electrical arcing or fire can result. To minimize the risk of fire if the breaker has tripped, shut off the power and repair the system immediately. Do not attempt to repair or energize damaged cable. Damaged heating cable or components can cause electrical shock, arcing, and fire. Remove damaged sections at once and replace them with a new length using the appropriate nVent RAYCHEM splice kit.</p> <p>⚠ AVERTISSEMENT: Risque d'incendie. Un disjoncteur différentiel de mise à la terre qui a sauté pourrait vouloir dire que le câble chauffant a été endommagé ou installé incorrectement et ne doit donc pas être ignoré. Il pourrait en résulter un arc électrique continu ou un incendie. Pour réduire le risque d'incendie lorsqu'un disjoncteur a sauté, couper le courant et réparer le système immédiatement.</p>	Nick or cut in heating cable or power feed wire with moisture present.	Replace damaged cable.
	Circuit breaker undersized.	Resize the circuit breaker and wiring if applicable.
	Circuit oversized.	Same as above.
	Startup at too low a temperature.	Same as above.
	Defective circuit breaker.	Replace circuit breaker.
	Connections shorting out.	<p>To locate shorting problems, follow these steps:</p> <ul style="list-style-type: none"> • Visually inspect the power connections, splices, tees, and end seals for proper installation; correct as necessary. • Check for visual indications of damage around the valves, pump, and any area where there may have been maintenance work. • Look for crushed or damaged insulation lagging along the pipe. Replace damaged sections of heating cable. Using a megohmmeter, test per installation instructions.
	Physical damage to heating cable causing a direct short.	Same as above.
	Bus wires connected at the end.	Check end seal junction box to ensure bus wires are secured properly in terminal block. The heating cable may have been permanently damaged by excessive current and may need to be replaced.
	Excessive moisture in connection boxes or splices.	Dry out and reseal connections and splices. Using a megohmmeter, test per installation instructions.

TROUBLESHOOTING GUIDE

Symptoms	Probable Causes	Correction
Power output appears correct but pipe temperatures are below design value.	Insulation is wet.	Remove and replace it with dry insulation, and secure proper weatherproofing.
	Insufficient heating cable was used on valves, supports, and other heat sinks.	Splice in additional heating cable but do not go over maximum circuit length.
	Thermostat was set incorrectly.	Reset thermostat.
	Improper thermal design.	Check with the local or factory representative for design conditions; modify as recommended.
Power output is zero or appears low.	Low or no input voltage.	Repair electrical supply lines and equipment.
	Circuit is shorter than the design shows, due to splices or tees not being connected, or the heating cable having been severed.	Check routing and length of heating cable (use "as built"). Connect splices or tees, locate and replace the damaged heating cables, then recheck the power.
	Improper connection causing a high-resistance connection.	Recrimp with the correct procedure. Tighten set screws on terminal block.
	Control thermostat is wired in normally open position.	Rewire in the normally closed position.
	Pipe is at an elevated temperature.	Reduce pipe temperature. Check the pipe temperature. Verify the power output of heating cable. See note below for method.
	Heating cable has been exposed to excessive moisture or chemicals.	Replace damaged heating cable. Check the pipe temperature. Verify the power output of heating cable. See note below for method.
	Heating cable has been exposed to excessive temperatures.	Same as above.
<p>Note: The power output is temperature-sensitive and requires a special procedure to determine its value:</p> <ol style="list-style-type: none"> 1. Check the pipe temperature under the thermal insulation at several locations. 2. Power the heating cable and allow it to stabilize for 10 minutes, then measure current and voltage at the junction box. 3. Calculate the power (watts/ft) of the heating cable by multiplying the current by the voltage and dividing by the actual circuit length. $\text{Power (watts/ft)} = \frac{\text{Current (A)} \times \text{Voltage (Vac)}}{\text{Length (ft)}}$		

⚠ WARNING: OPEN CIRCUIT BEFORE REMOVING COVER. KEEP COVER TIGHT WHILE CIRCUITS ARE ALIVE.

⚠ ATTENTION: OUVRIR LE CIRCUIT AVANT D'ENLEVER LE COUVERCLE. GARDER LE COUVERCLE BIEN FERMÉ TANT QUE LES CIRCUITS SONT SOUS TENSION

FM REQUIRED DIVISION 1 INSTALLATION RECORD

To complete the FM approval process, fill out this form and return it to the nVent Customer Service Center (fax number (650) 361-6711).

Company Name	Purchase Order No.	Reference Drawing(s)
Circuit ID No.	Initials	Test Value/ Remarks Date

AREA:

Auto-ignition temperature (AIT)
Group classification

HEATER CIRCUIT:

Heating cable type
Supply voltage
Circuit length
Maximum pipe temperature
Heat temp. identification number (T-rating)

COMPONENTS:

Power connection
End seal
Tee connection
Spice

INSTALLATION INSTRUCTIONS:

Correct components per manufacturer's specification
Seal fittings opened and inspected (properly poured)
Ground-leakage device tested

GROUND-FAULT EQUIPMENT

Make and model
Ground-fault equipment protection device trip level (mA)

INSTALLATION INSTRUCTIONS:

Correct components per manufacturer's specification
Seal fittings opened and inspected (properly poured)
Ground-leakage device tested

GROUND-FAULT EQUIPMENT PROTECTION:

Make and model
Ground-fault equipment protection device trip level (mA)

INSULATION RESISTANCE TESTING:

Minimum insulation resistance must be 1000 mΩ. If less than 1000 mΩ see Troubleshooting Guide (pages 12 and 13).

Heating Cable Test 1 (refer to Step 16a and b of HAK-C-100 installation instructions)

Instrument used:	Calibration due date:		
Measured before thermal insulation is installed:	500 Vdc	1000 Vdc	2500 Vdc
Date:	Insulation Resistance Test A (Ω)		
Date:	Insulation Resistance Test B (Ω)		

Post-Thermal-Insulation Heating Cable Test 2 (refer to Steps 21 and 16b of HAK-C-100 installation instructions)

Instrument used:	Calibration due date:		
Measured after thermal insulation is installed:	500 Vdc	1000 Vdc	2500 Vdc
Date:	Insulation Resistance Test A (Ω)		
Date:	Insulation Resistance Test B (Ω)		

Circuit Ready to Commission

Prepared by	Company	Date
Approved by	Company	Date

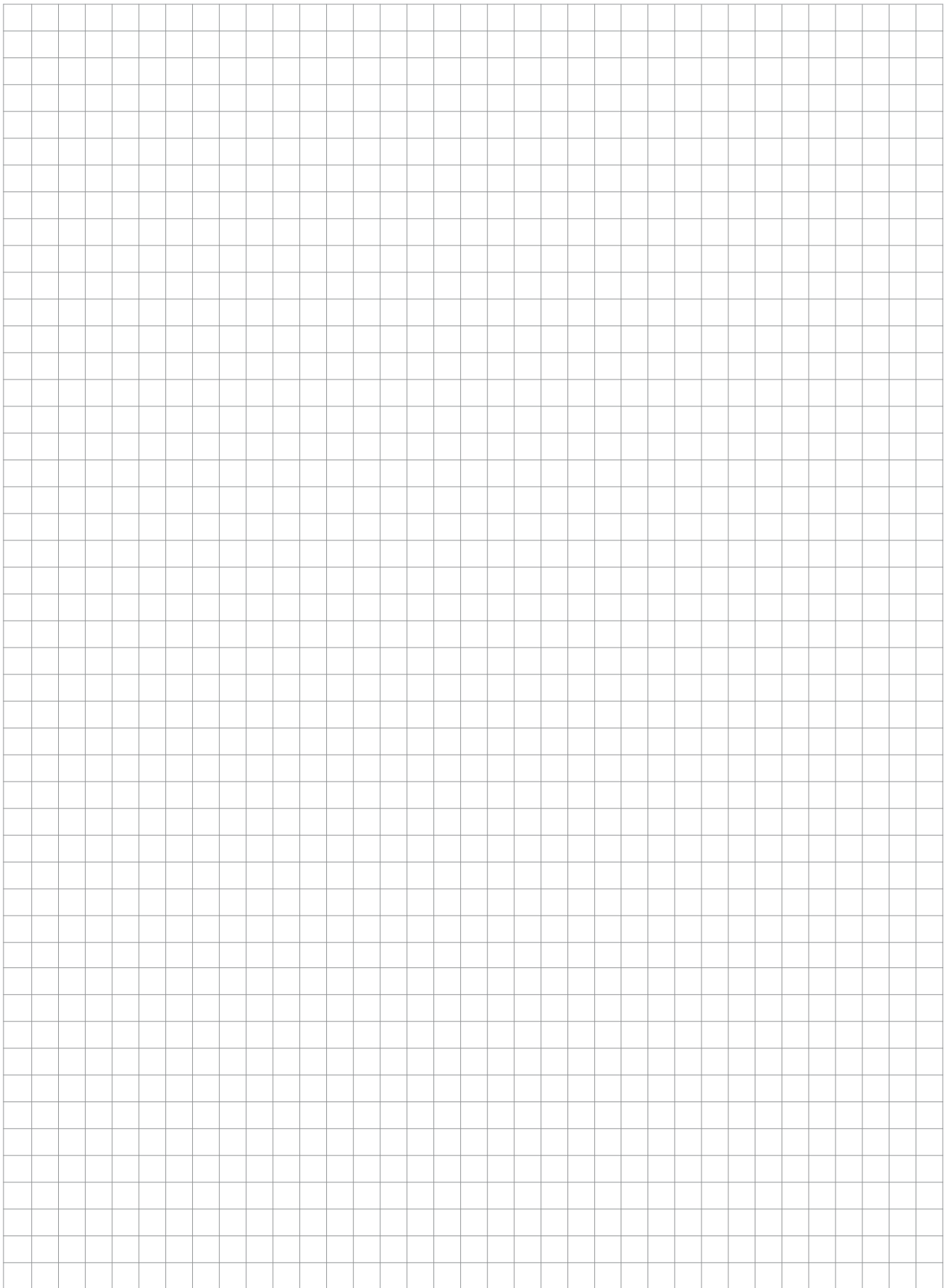

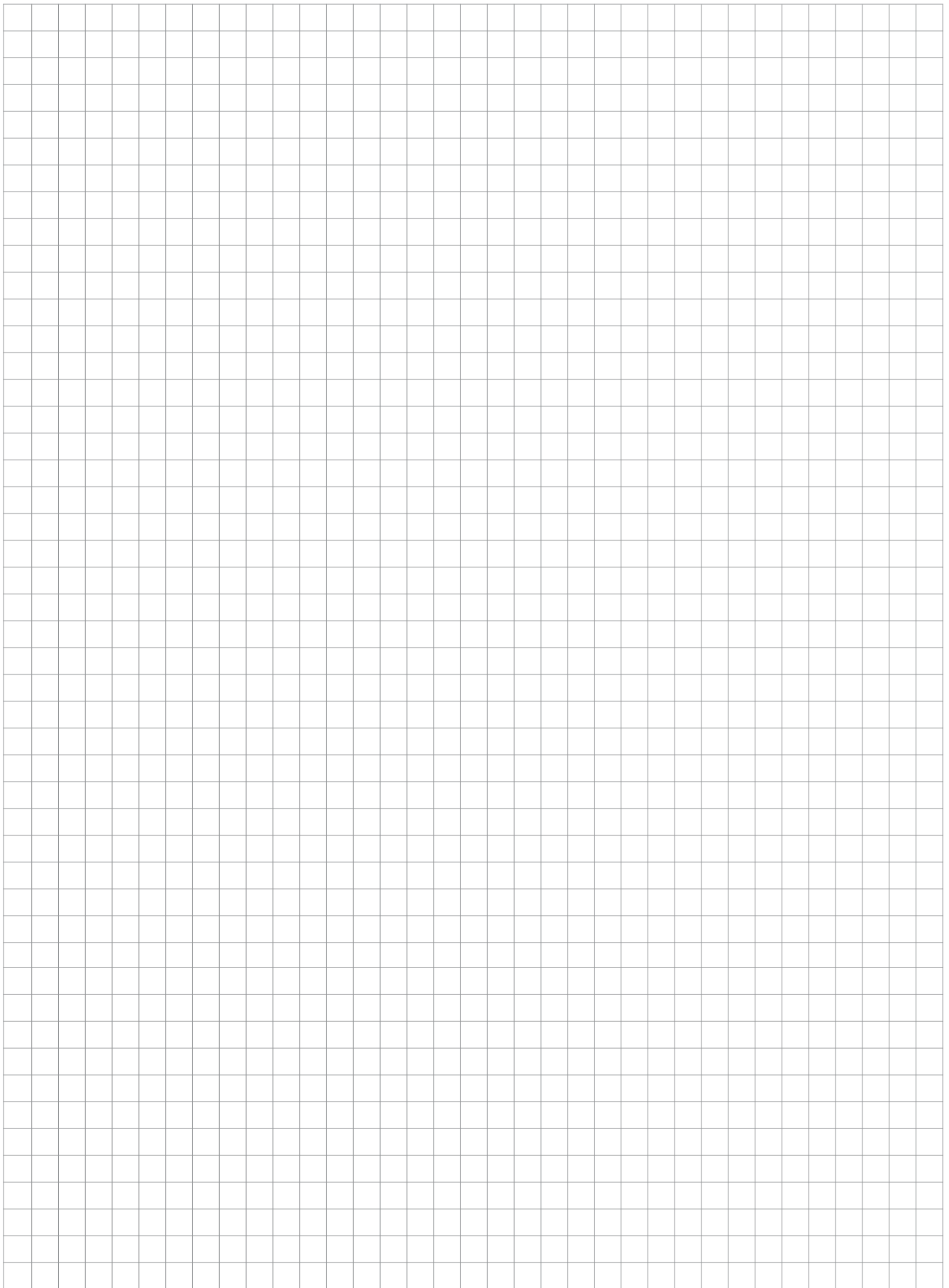

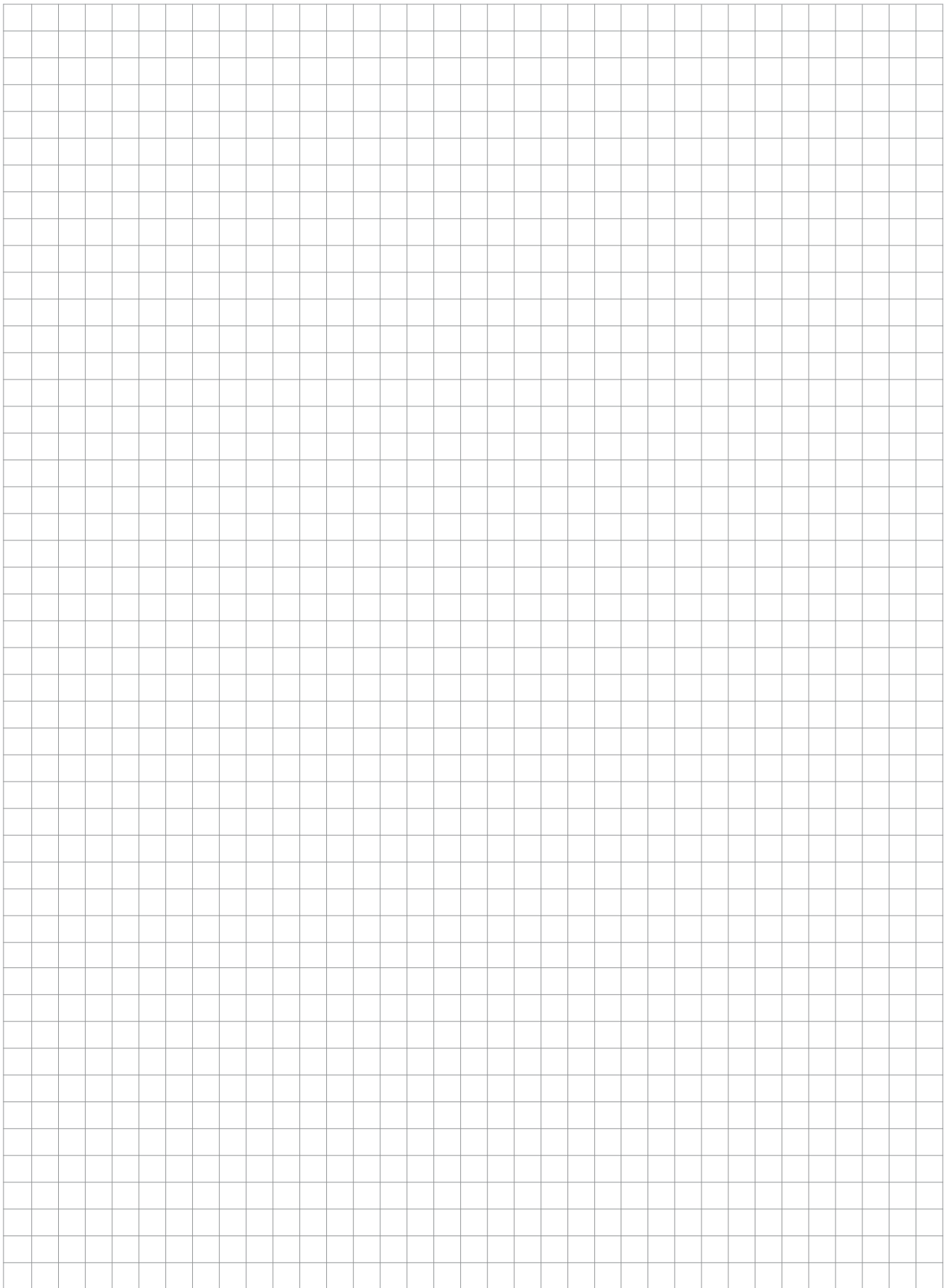

North America

Tel +1.800.545.6258
Fax +1.800.527.5703
thermal.info@nVent.com

Europe, Middle East, Africa

Tel +32.16.213.511
Fax +32.16.213.604
thermal.info@nVent.com

Asia Pacific

Tel +86.21.2412.1688
Fax +86.21.5426.3167
cn.thermal.info@nVent.com

Latin America

Tel +1.713.868.4800
Fax +1.713.868.2333
thermal.info@nVent.com



nVent.com/RAYCHEM

©2022 nVent. All nVent marks and logos are owned or licensed by nVent Services GmbH or its affiliates. All other trademarks are the property of their respective owners.
nVent reserves the right to change specifications without notice.

RAYCHEM-IM-H56573-HAKC100IND-EN-2206