

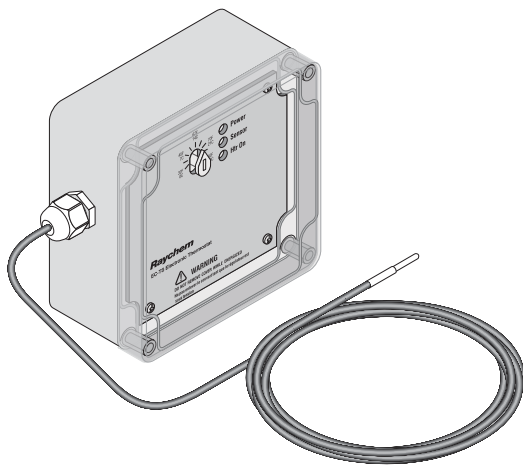

RAYCHEM

EC-TS

Ambient, Pipe or Slab Sensing Electronic Thermostat With 25 Foot Temperature Sensing Lead Installation Instructions



DESCRIPTION

The nVent RAYCHEM EC-TS electronic thermostat is an ambient, pipe, or slab sensing thermostat that is ideal for pipe freeze protection, flow maintenance, freezer frost heave and floor heating and snow melting applications. The EC-TS can be used to control a single heat-tracing circuit or as a pilot to control a contactor switching multiple heat-tracing circuits. The temperature set point can be visually checked through the clear lid, as can the LED indicators for alarm, power and heating cable status. The stainless steel sensor makes it an ideal thermostat for applications that require an embedded sensor.

The set point range for these thermostats is between 30°F (-1°C) and 110°F (43°C). It operates at voltages between 100 to 277 Vac and switches current to 30 Amps.

For technical support call nVent at (800) 545-6258.

TOOLS REQUIRED

- Large slotted screwdriver
- Needle nose pliers
- Small slotted screwdriver

ADDITIONAL MATERIALS REQUIRED

- Appropriate mounting fasteners
- MI cable grounding kit (for direct connection of Pyrotex heating cables) Catalog No: MI-GROUND-KIT

APPROVALS



KIT CONTENTS

Item	Qty	Description
A	1	Lid
B	1	Wire cover
C	1	Box with electronics
D	1	25 foot temperature sensor
E	1	MI cable grounding kit (P000000279)
F	1	Pipe support bracket (optional; 707366)

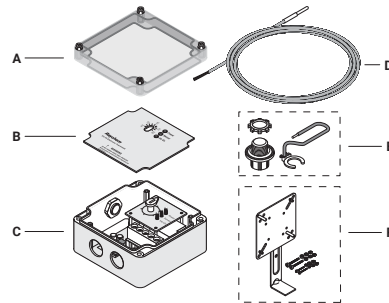

⚠ WARNING:

This component is an electrical device that must be installed correctly to ensure proper operation and to prevent shock or fire. Read these important warnings and carefully follow all of the installation instructions.

- To minimize the danger of fire from sustained electrical arcing if the heating cable is damaged or improperly installed, and to comply with the requirements of nVent, agency certifications,

and the National Electrical Code, ground-fault equipment protection must be used. Arcing may not be stopped by conventional circuit breakers.

- Component approvals and performance are based on the use of nVent-specified parts only. Do not use substitute parts or vinyl electrical tape.
- The black heating cable core and fibers are conductive and can short. They must be

properly insulated and kept dry.

- Damaged bus wires can overheat or short. Do not break bus wire strands when scoring the jacket or core.
- Keep components and heating cable ends dry before and during installation.
- Use only fire resistant insulation materials, such as fiberglass wrap or flame-retardant foam.

1

- Attach enclosure to the wall using the appropriate mounting fasteners.

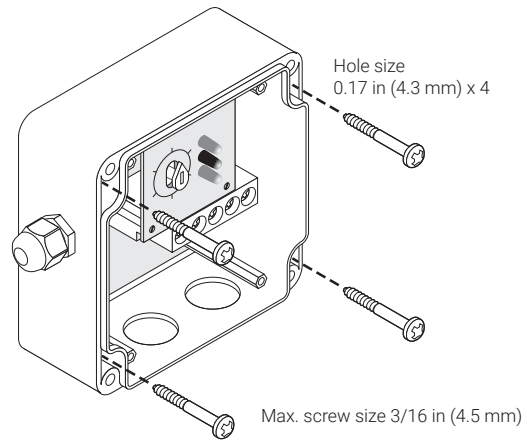

2A Heating Cable using a Junction Box

Connecting Heating Cable

- Insert the two power wires from the heating cable's junction box into the terminal block marked "To Heating Cable" and the ground (braid) marked "Earth" and tighten terminals. Confirm connection by pulling on the wires.

Note: You must bring grounding wire from the MI junction box to the controller for the ground-fault circuit breaker to work properly.

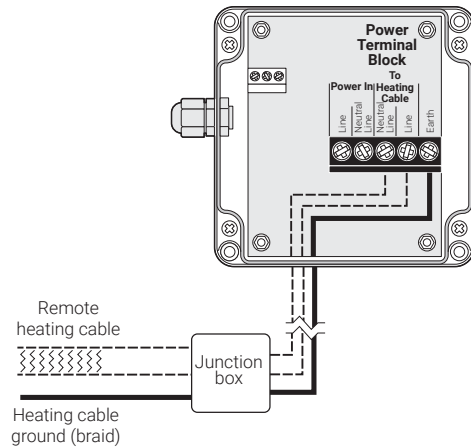

2B Mineral Insulated Heating Cable using a Direct Connection without a Separate Junction Box

Note: To ensure the MI heating cable is properly grounded, all MI cables must be installed with a grounding kit, which is ordered separately (P000000279). Failure to use the grounding kit will void the warranty and can be a safety hazard by preventing normal operation of the ground fault circuit breaker.

- Insert the two heating cable wires into the terminal block marked "To Heating Cable" and the ground wire to "Earth" and tighten terminals. Confirm by pulling on the wires.

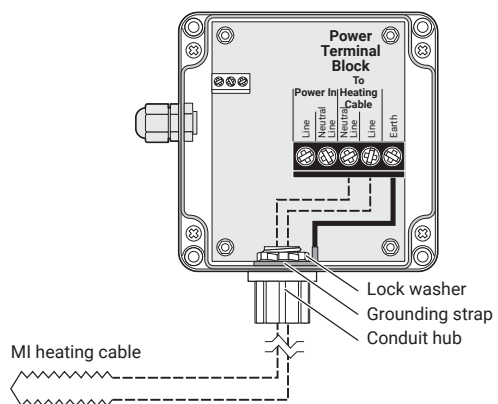

3

Connecting Incoming Power

- Pull in 8 to 14 AWG power and ground wires, strip off 1/2 in (3 mm) of insulation and terminate. Confirm by pulling on the wires.

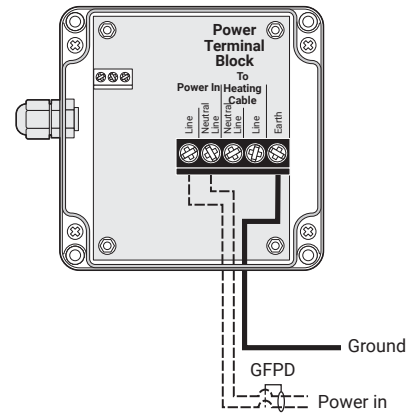

4

Preparing Sensor

- Cut the sensor lead wire to length.
- Being careful not to cut the wires, strip 1-1/2 inches of outer jacket, trim off foil, to expose black white and non insulated drain wire (ground/shield).

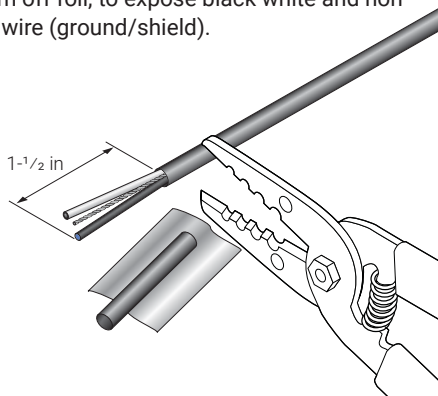

5

- Strip off 1/4 inch of insulation from black and white wires. Do not cut the wire strands.

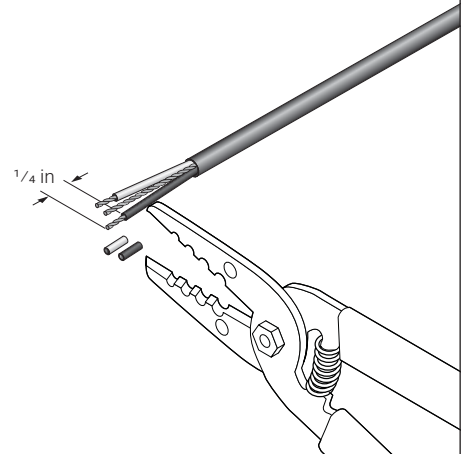

6A

Placing Sensor: Ambient Application

- Remove cap and grommet. Slide grommet over temperature sensor and onto shrink tubing. Tighten cap.

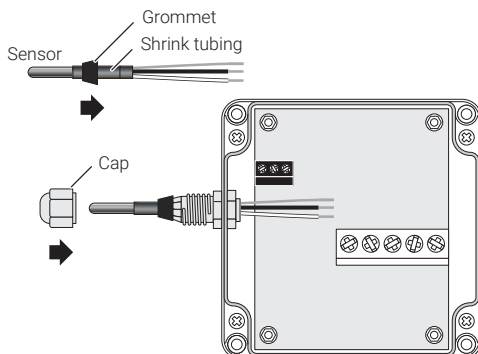

6B

Placing Sensor: Pipe/Slab Application

- Remove cap and compression grommet. Slide cable through cap, grommet and through side entry hole. Tighten cap.

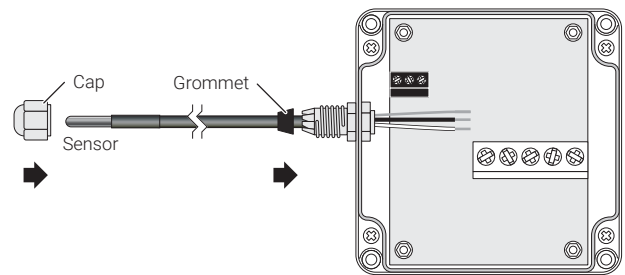

Connecting Sensor

- Insert the three sensor wires into the terminal block marked "Sensor Input." Match the colors (White to W, Black to B), and tighten terminals. Confirm connection by pulling on the wires.

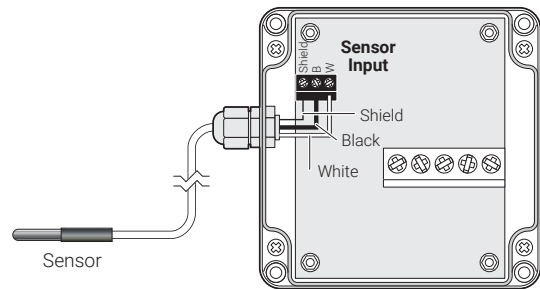

8 Finished Wiring Diagram

- Install wire cover.
- Turn pointer to the desired set point.
- Install lid.
- Leave these instructions with the end user for future reference.

Function	LED color	Description
Power	Green	When energized, indicates power to the controller
Sensor	Red	When energized, indicates shorted or open sensor
Htr On	Green	When energized, indicates power to the heating cable

Heating cable using a junction box

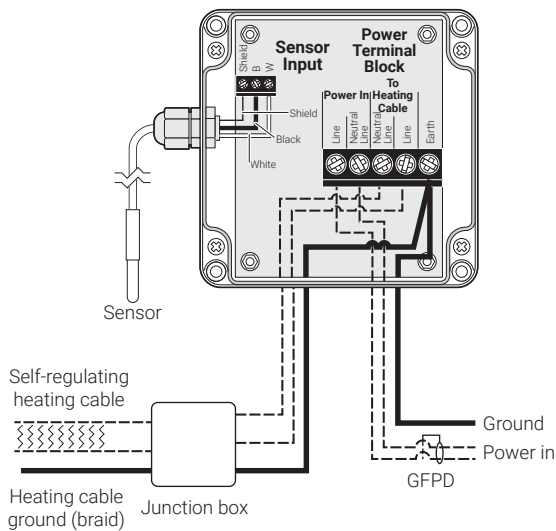

MI heating cable using direct connection

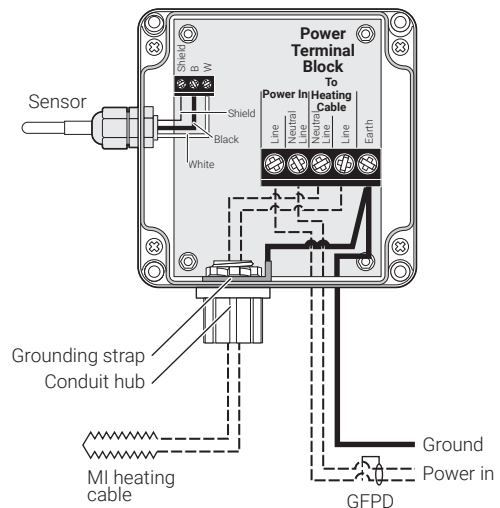

North America

Tel +1.800.545.6258
Fax +1.800.527.5703
thermal.info@nvent.com

Europe, Middle East, Africa

Tel +32.16.213.511
Fax +32.16.213.604
thermal.info@nvent.com

Asia Pacific

Tel +86.21.2412.1688
Fax +86.21.5426.3167
cn.thermal.info@nvent.com

Latin America

Tel +1.713.868.4800
Fax +1.713.868.2333
thermal.info@nvent.com



nVent.com