

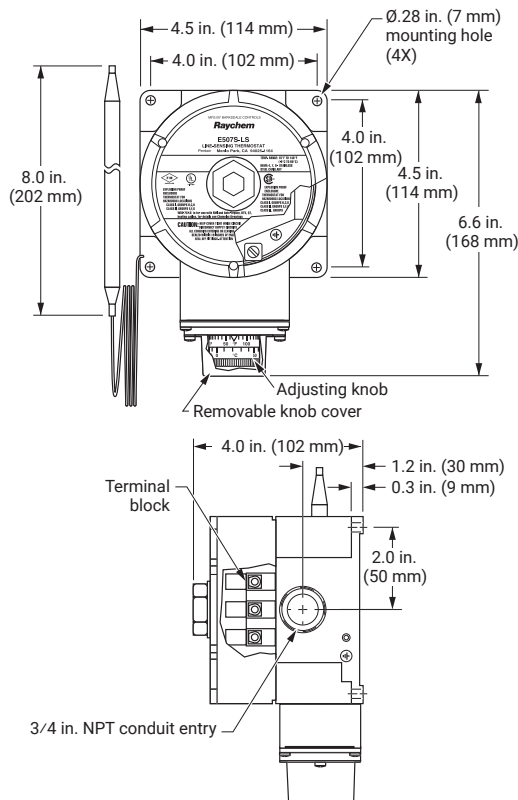

RAYCHEM

E507S-LS

Line-Sensing Thermostat for Hazardous Locations Installation Instructions

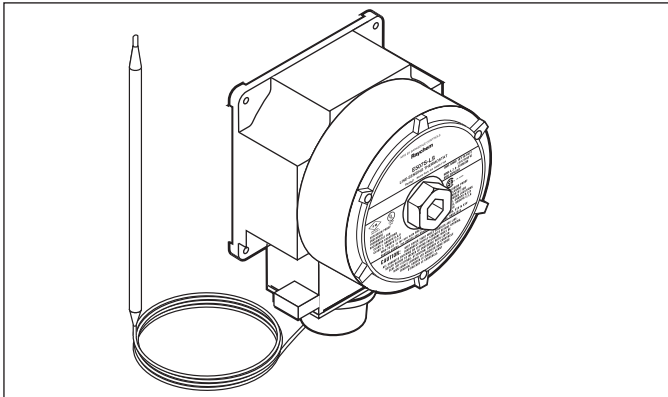

DESCRIPTION

The nVent RAYCHEM E507S-LS thermostat is designed for controlling heat-tracing systems in hazardous locations. The E507S-LS can be used to control heat-tracing circuits in a pipe-sensing mode (see Figure 1 on back page), to indicate low-temperature (see Figure 2) or high-temperature (see Figure 3) alarm conditions, or to control the coil on a contactor (see Figure 4).

APPROVALS

Hazardous locations



Class I, Div. 1 and 2, Groups B, C, D
Class II, Div. 1 and 2, Groups E, F, G
Class III

SPECIFICATIONS

Enclosure	NEMA 4, 7, 9, lacquer-coated cast-aluminum housing, stainless-steel hardware
Entries	One 3/4 in. NPT conduit hub
Set point range	25°F to 325°F (-4°C to 163°C)
Sensor exposure limits	-40°F to 420°F (-40°C to 215°C)
Housing exposure limits	-40°F to 140°F (-40°C to 60°C)
Switch	SPDT
Electrical rating	22 A at 125/250/480 Vac
Accuracy	\pm 6°F (\pm 3.3°C)
Deadband	2°F to 12°F (1.1°C to 6.7°C) above actuation temperature
Set point repeatability	\pm 3°F (\pm 1.7°C)
Sensor type	Fluid-filled (silicone) bulb and 9 ft (2.7 m) capillary
Sensor material	300 series stainless steel
Connection terminals	Screw terminals, 10-14 AWG (2-5 mm ²)

WARNING:

This component is an electrical device. It must be installed correctly to ensure proper operation and to prevent shock or fire. Read these important warnings and carefully follow all the installation instructions.

Component approvals and performance are based on the use of specified parts only. Do not use substitute parts or vinyl electrical tape to make connections.

INSTALLING THE THERMOSTAT

1. Verify that the thermostat is suitable for the area where it is to be installed.
2. Check the line voltage and the heat-tracing load to ensure that the thermostat ratings are not exceeded.
3. Mount the unit using unistrut or the RAYCHEM universal mounting bracket (UMB-263757) in a position that prevents condensation from draining into the enclosure from the connecting conduit (see diagram above).

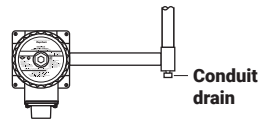

POSITIONING THE SENSOR BULB

4. Position the bulb in the lower quadrant of the pipe as shown in the diagrams to the left. Place the bulb at least three feet from pipe supports, valves, or other heat sinks; protect the capillary from kinks or bends less than 1/2 inch in radius.

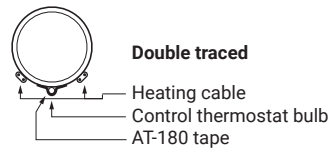
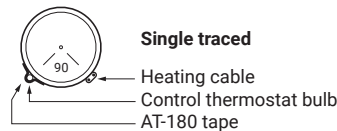

5. Tape the bulb firmly to the pipe with AT-180 aluminum tape, making sure there is no air space between the bulb and pipe. Do not overlap the bulb and heating cable with the same piece of AT-180 tape.
6. For metal-tank-wall sensing, use the BCK-35 bulb clamp (purchased separately) and install the clamp per the instructions provided. Make sure there is no air space between the tank wall and the bulb.
For installation on plastic tanks, contact nVent at (800) 545-6258.

SETTING THE THERMOSTAT

7. Set the thermostat dial to the desired temperature, then finish wiring.
8. Complete insulating. Do not turn the system on until the bulb is covered with thermal insulation.
9. Fill the piping or tank. Once the thermostat has begun to cycle, check the fluid temperature with an immersed thermostat (best for plastic systems) or an accurate temperature indicator. Adjust the dial setting if necessary.

WIRING

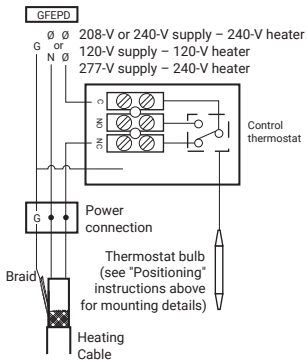

Figure 1. Pipe-sensing

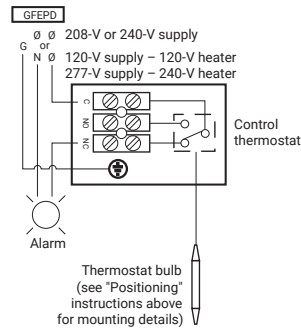

Figure 2. Low-temperature alarm

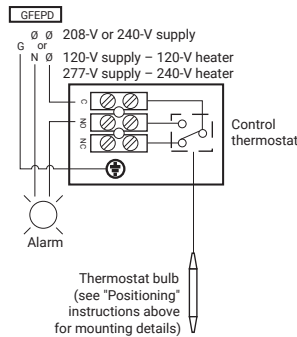

Figure 3. High-temperature alarm

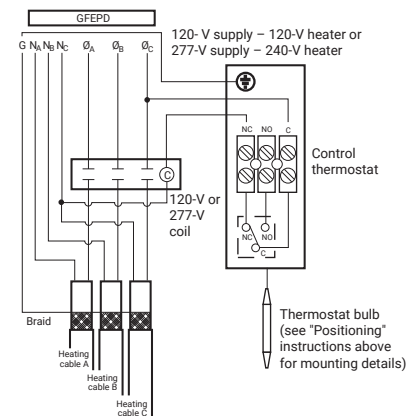

Figure 4. Contactor control

For switching heat-tracing loads greater than 22 A or switching multiple heat-tracing circuits.

North America
Tel +1.800.545.6258
Fax +1.800.527.5703
thermal.info@nvent.com

Europe, Middle East, Africa
Tel +32.16.213.511
Fax +32.16.213.604
thermal.info@nvent.com

Asia Pacific
Tel +86.21.2412.1688
Fax +86.21.5426.3167
cn.thermal.info@nvent.com

Latin America
Tel +1.713.868.4800
Fax +1.713.868.2333
thermal.info@nvent.com



nVent.com