

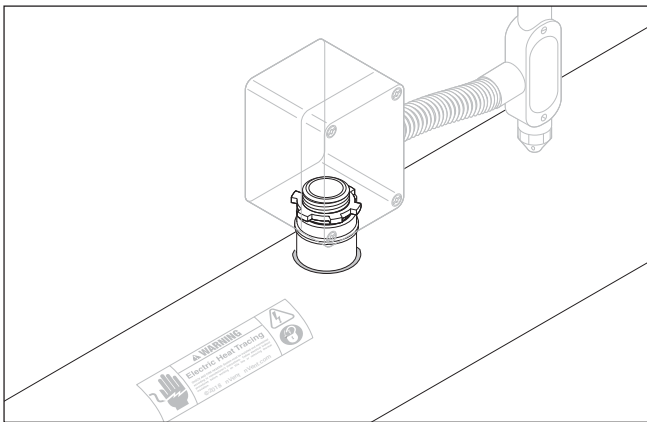

RAYCHEM

JS-100-A

Junction Box Stand Installation Instructions



DESCRIPTION

The nVent RAYCHEM JS-100-A is a Single Entry Power Connection Transition kit. It is designed for use with RAYCHEM BTV-CR, BTV-CT, QTVR-CT, XTV-CT, KTV-CT, and VPL-CT industrial parallel heating cables. The kit is NEMA 4X rated only when used with an appropriate junction box.

This kit may be installed at temperatures as low as -40°F (-40°C). For easier installation store above freezing until just before installation. For technical support call nVent at (800) 545-6258.

TOOLS REQUIRED

- Utility knife
- Needle nose pliers
- Wire cutters
- 3/16 in or smaller slotted screwdriver
- Two pair channel lock pliers
- Large slotted screwdriver
- Marker
- Wire stripper (for VPL)

ADDITIONAL MATERIALS REQUIRED

- Pipe strap
- GT-66 or GS-54 glass cloth tape
- NEMA 4X rated junction box with 1 in NPS threaded entry or through hole

OPTIONAL MATERIALS

- Recommended conduit drain: JB-DRAIN-PLUG-3/4IN P/N 278621-000
- Small pipe adapter for 1 in (25 mm) and smaller pipes: Catalog number JBS-SPA P/N E90515-000

APPROVALS

Hazardous Locations



Class I, Div. 2, Groups A, B, C, D
Class II, Div. 2, Groups F, G
Class III

KIT CONTENTS

Item	Qty	Description
A	1	Stand assembly
B	1	Cable lubricant
C	1	1 in locknut
D	1	Terminal block
E	1	Cable tie
F	1	Green/yellow tube
G	1	CS-100 cold applied core sealer
H	1	JS-100 transition

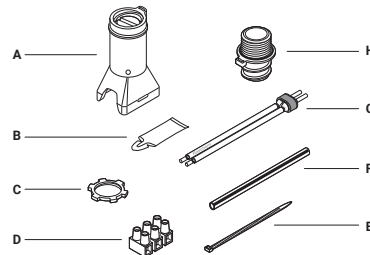

WARNING:

This component is an electrical device that must be installed correctly to ensure proper operation and to prevent shock or fire. Read these important warnings and carefully follow all of the installation instructions.

- To minimize the danger of fire from sustained electrical arcing if the heating cable is damaged or improperly installed, and to comply with the requirements of nVent, agency certifications, and national electrical codes, ground-fault equipment protection must be used. Arcing may not be stopped by conventional circuit breakers.

- Component approvals and performance are based on the use of nVent-specified parts only. Do not use substitute parts or vinyl electrical tape.
- The black heating cable core and fibers are conductive and can short. They must be properly insulated and kept dry.
- Damaged bus wires can overheat or short. Do not break bus wire strands when scoring the jacket or core.
- Keep components and heating cable ends dry before and during installation.
- Use only fire-resistant insulation materials, such as fiberglass wrap or flame-retardant foam.

CAUTION:

HEALTH HAZARD: Prolonged or repeated contact with the sealant in the core sealer may cause skin irritation. Wash hands thoroughly. Overheating or burning the sealant will produce fumes that may cause polymer fume fever. Avoid contamination of cigarettes or tobacco. Consult MSDS VEN 0058 for further information.

CHEMTREC 24-hour emergency telephone:
(800) 424-9300

Non-emergency health and safety information:
(800) 545-6258.

Heating cable types

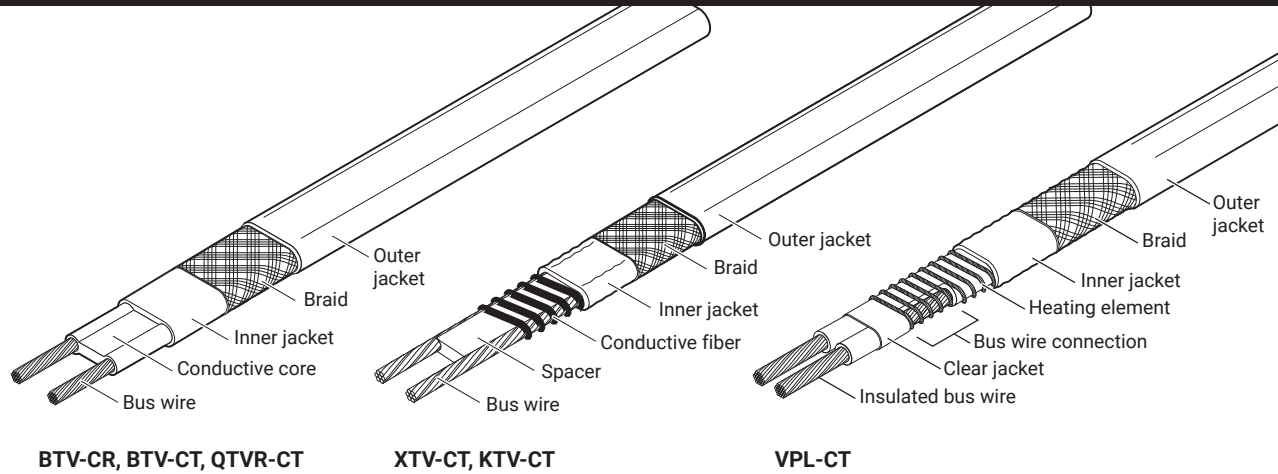

1

- Allow approximately 24 in (60 cm) of heating cable for installation. For VPL, cut cable 12 in (30 cm) from bus indentation.
- Cut off heating cable end at about 45° for easier insertion.
- Apply cable lubricant to end of the heating cable for easier insertion into stand.

Indentation (bus wire connection on VPL heating cables only).

12 in (30 cm)

2

- Optional: If stand is to be installed on bottom side of pipe, knock out drain hole prior to inserting cable.
- Push 18 in (45 cm) of heating cable through stand.
- Square off cable end with 90° cut.

18 in (45 cm)

Drain hole

- Do not attach stand to pipe until step 12.

3

- Lightly score outer jacket around and down as shown.
- Bend heating cable to break jacket at score, then peel off jacket.

Do not cut braid.

7 1/2 in (190 mm)

4

BTV and QTVR Go to Step 5A

XTV and KTV Go to Step 5B

VPL Go to Step 5C

5A

BTV and QTVR

- Push braid back to create a pucker.
- At pucker use a screwdriver to open braid.

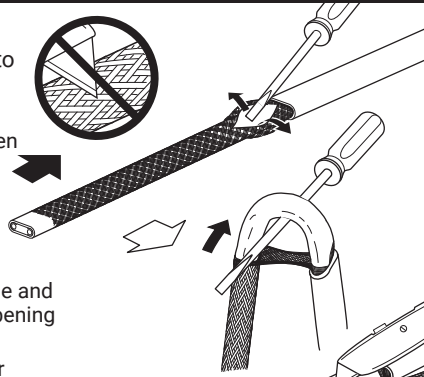

- Bend heating cable and work it through opening in braid.
- Lightly score inner jacket around and down as shown.

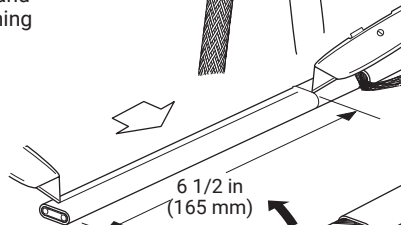

- Peel off inner jacket.

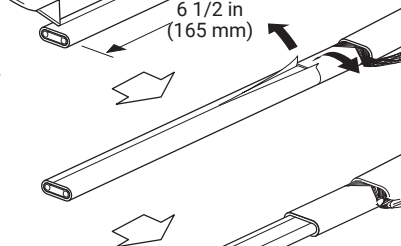

- Notch core.

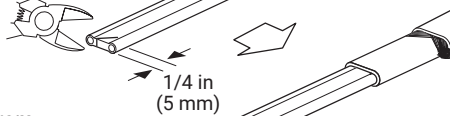

- Peel bus wire from core.

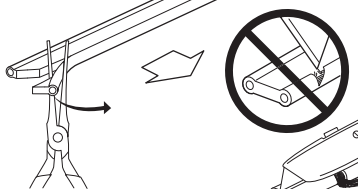

- Score core between bus wires at inner jacket.
- Bend and snap core.

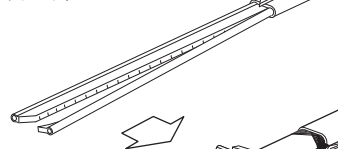

- Peel core from bus wire.
- Remove any remaining core material from bus wires.
- Pull braid tight to make pigtail.

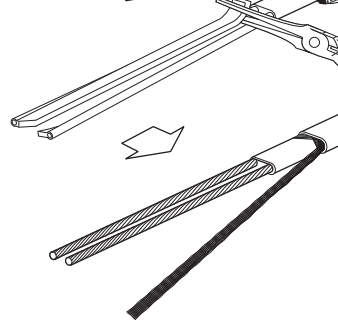

Go to Step 6

5B

XTV and KTV

- Push braid back to create a pucker.
- At pucker use a screwdriver to open braid.

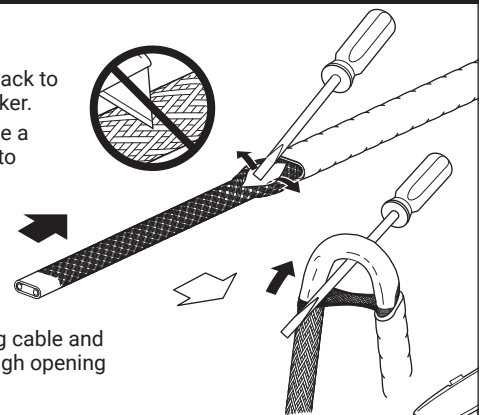

- Bend heating cable and work it through opening in braid.

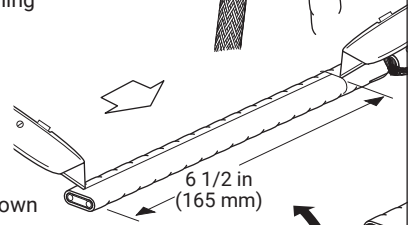

- Lightly score inner jacket around and down as shown.

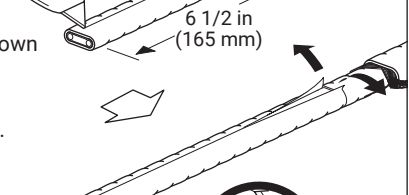

- Peel off inner jacket.

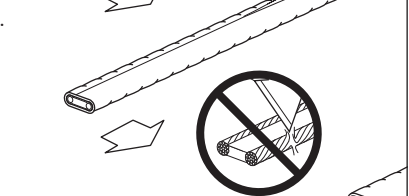

- Cut and remove all fiber strands.

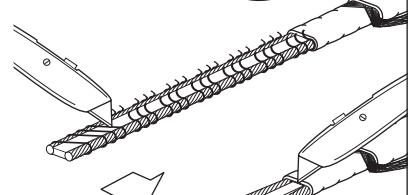

- Score and remove center spacer.

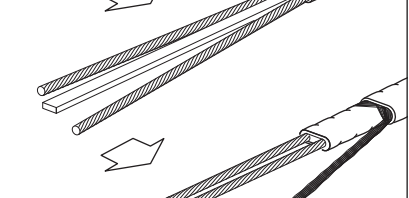

- Remove any remaining fiber material from bus wires.
- Pull braid tight to make pigtail.



Go to Step 6

- Push braid back and bunch as tight as possible.



- Lightly score inner jacket around and down as shown.

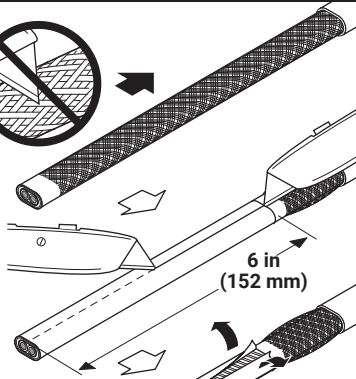

- Peel off inner jacket.



- Unwind heating element, cut and remove as shown.



- Lightly score clear jacket around and down as shown.

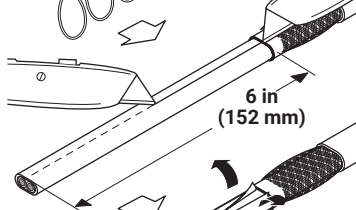

- Bend heating cable to break jacket at the score then peel off jacket.



- Push braid forward. Use a screwdriver to open braid as shown.

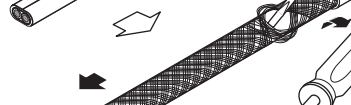

- Bend heating cable and work it through opening in braid.



- Remove insulation from ends of bus wires.
- Pull braid tight to make pigtail.

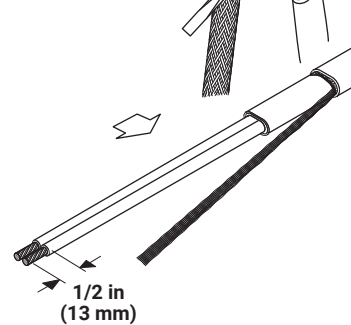

Go to Step 6

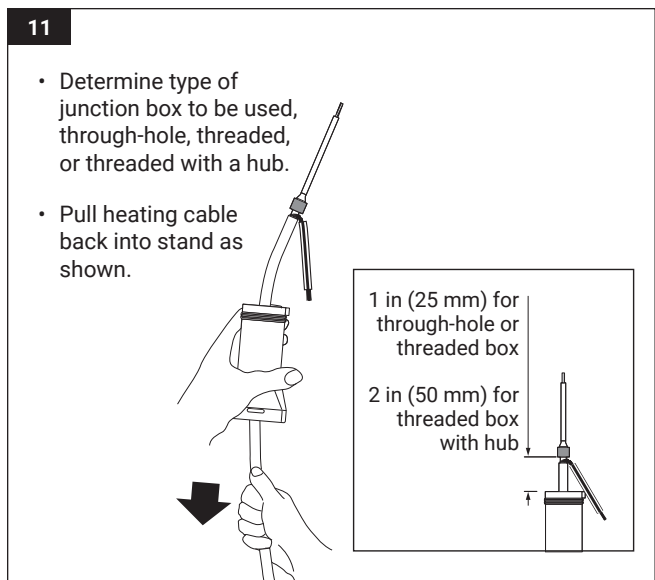
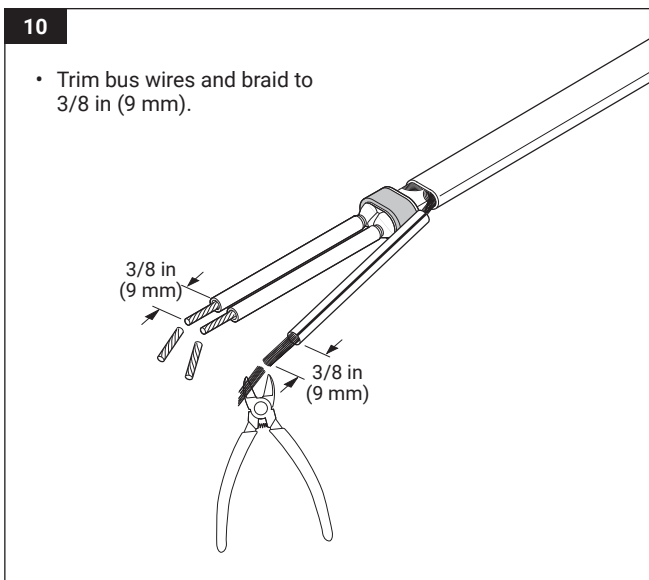
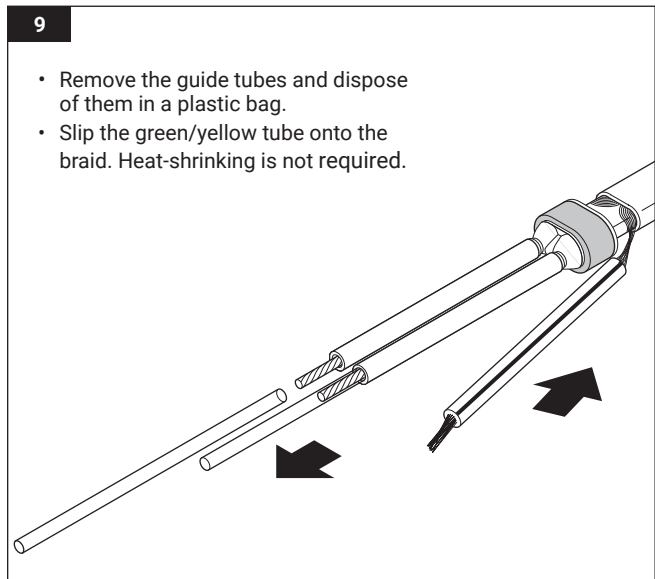
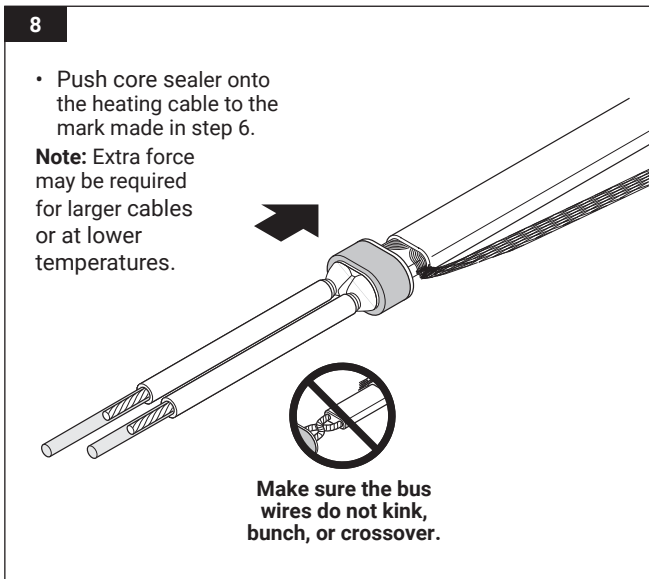
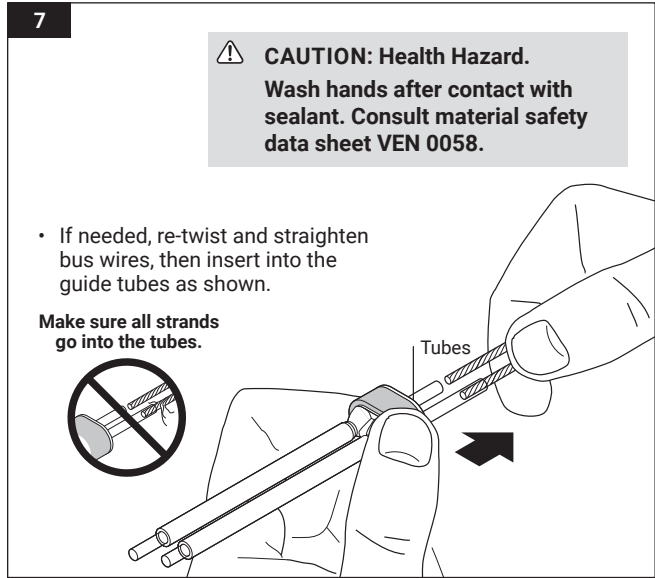
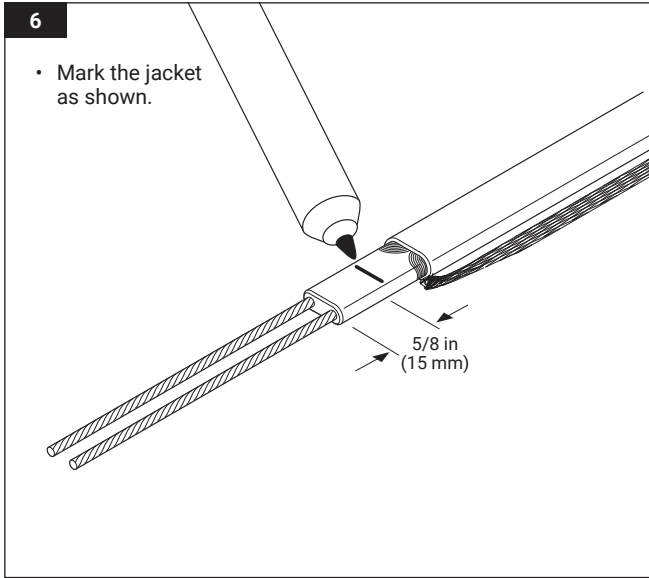

12

- Fasten stand to pipe.
Do not pinch heating cable.
- Loop and tape extra heating cable to pipe. Minimum bend radius 3/4 in (20 mm).

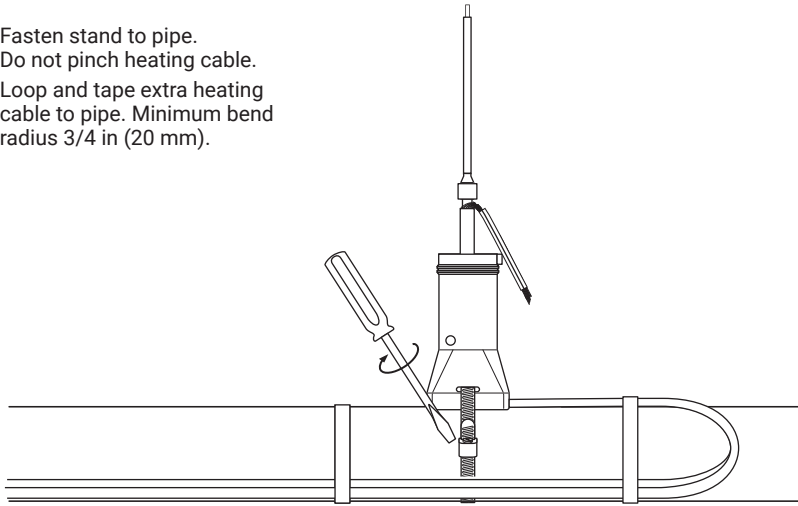

Note: For 1 in (25 mm) and smaller pipes use adapter (purchased separately) and install between stand and pipe.

JBS-SPA adapter for small pipes

Position adapter this side up.

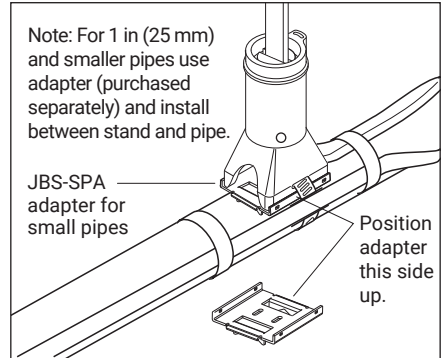

13

- Screw transition onto stand until it stops. Tighten until slots on transition and stand align. Do not damage threads on transition.

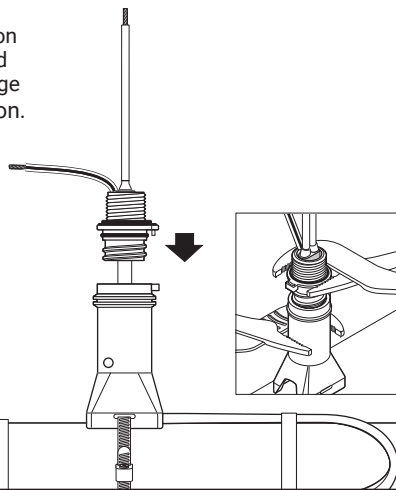

14

- Insert cable tie through slots on stand and transition and tighten firmly to prevent transition rotation.

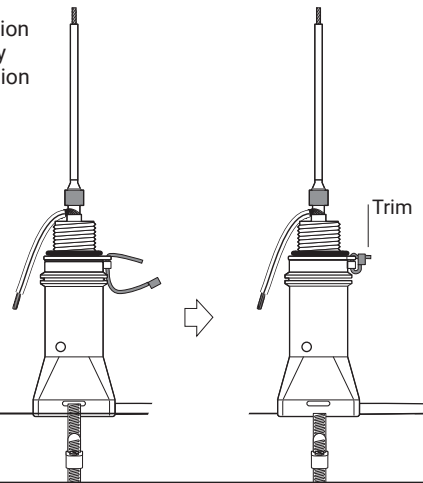

15

For through-hole box

- Make sure o-ring is seated in groove on transition.
- Place box onto transition and install locknut.
- Tighten locknut.

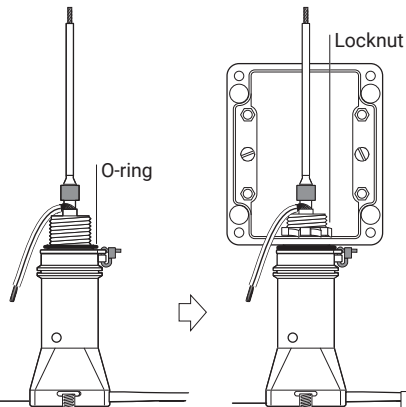

For threaded box

- Screw box onto transition.
- Tighten junction box.

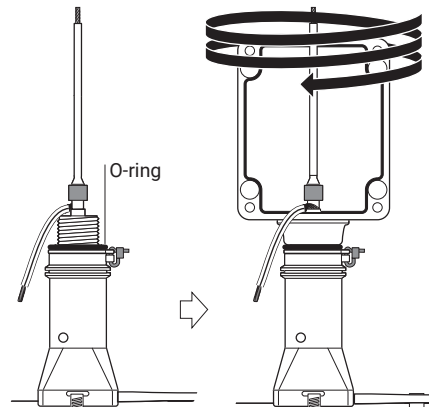

16

- Install conduit and fittings as shown. To minimize loosening due to vibration, use flexible conduit.
- Pull in power and ground wires, strip off 3/8 in (9 mm) of insulation.
- Use terminal block to connect bus wires and braid to power wiring. This connection must be protected by a ground-fault equipment protection device.

Make sure conductors are not exposed.



Ground wire

Braid

Water tight conduit seal

Conduit drain

nVent recommends the use of a conduit drain to prevent water condensation build-up.

17

- Install lid.
- Apply insulation and cladding.
- Weather-seal the stand entry.
- Leave these instructions with the end user for future reference.



Weather seal

North America

Tel +1.800.545.6258
Fax +1.800.527.5703
thermal.info@nvent.com

Europe, Middle East, Africa

Tel +32.16.213.511
Fax +32.16.213.604
thermal.info@nvent.com

Asia Pacific

Tel +86.21.2412.1688
Fax +86.21.5426.3167
cn.thermal.info@nvent.com

Latin America

Tel +1.713.868.4800
Fax +1.713.868.2333
thermal.info@nvent.com



nVent.com

©2018 nVent. All nVent marks and logos are owned or licensed by nVent Services GmbH or its affiliates. All other trademarks are the property of their respective owners. nVent reserves the right to change specifications without notice.

Raychem-IM-H56450-JS100A-EN-1805

PN 871765-000