

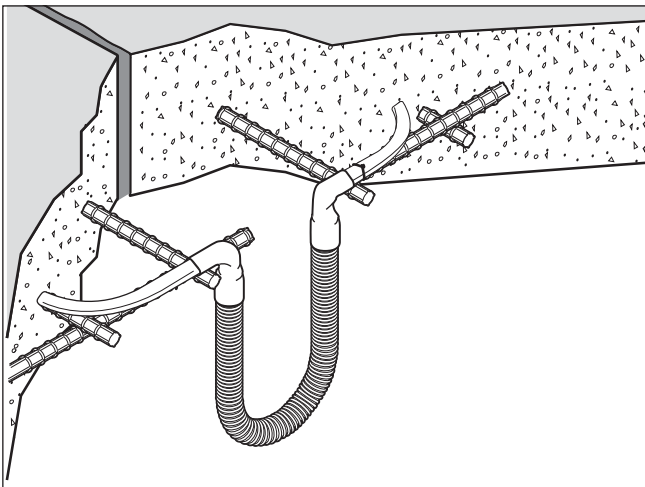

RAYCHEM

EMK-XEJ

Electromelt Expansion Joint Kit Installation Instructions



APPROVALS



De-icing and
Snow Melting Equipment

KIT CONTENTS

Item	Qty	Description
A	2	Heat-shrinkable tube – 1 1/2 x 6 in (38 x 152 mm)
B	1	Expansion tube – 1 x 24 in (25 x 610 mm)

DESCRIPTION

The nVent RAYCHEM EMK-XEJ Expansion Joint Kit is for use with ElectroMelt EM2-XR heating cable and is used to form an expansion loop at expansion joints. Materials for one expansion joint are included.

These installation instructions should be used in conjunction with the ElectroMelt System Design Guide (H53393) and ElectroMelt System Installation and Operation Manual (H58086). For technical support call nVent at (800) 545-6258.

TOOLS REQUIRED

- Heat gun or propane torch
- Wire strippers

ADDITIONAL MATERIALS REQUIRED

- EMK-XJB (Not shown) or equivalent UL Listed or CSA Certified weatherproof junction box suitable for the location. A minimum of 400 cubic inches are needed for 1 power connection and 1 end termination per junction box.

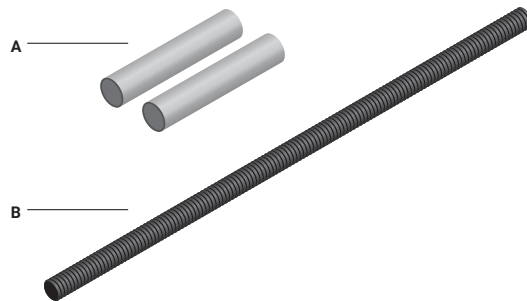

⚠ WARNING:

The heating cable is an electrical device that must be installed correctly to ensure proper operation and to prevent shock or fire. Read these important warnings and carefully follow all of the installation instructions.

- To minimize the danger of fire from sustained electrical arcing if the heating cable is damaged or improperly installed, and to comply with nVent, agency certifications, and national electric codes, ground-fault equipment protection must be used. Arcing may not be stopped by conventional circuit breakers.
- Component approvals and performance are based on the use of nVent specified parts only. Do not use substitute parts or vinyl electrical tape.
- The black heating-cable core is conductive and can short. It must be properly insulated and kept dry.

- Damaged bus wires can overheat or short. Do not break bus wire strands when scoring the jacket or core.
- Keep components and heating-cable ends dry before and during installation.
- Bus wires will short if they contact each other. Keep bus wires separated.
- Heat-damaged components can short. Use a heat gun or a torch with a soft, yellow, low-heat flame, not a blue focused flame. Keep the flame moving to avoid overheating, blistering, or charring the heat-shrinkable tubes. Avoid heating other components. Replace any damaged parts.
- Megohmmeters operate at high voltage. This voltage is hazardous and possibly lethal. Read and follow all instructions included with the instrument you are using.

⚠ CAUTION:

HEALTH HAZARD: Overheating heat-shrinkable tubes will produce fumes that may cause irritation. Use adequate ventilation and avoid charring or burning. Consult MSDS RAY3122 for further information.

CHEMTREC 24-hour emergency telephone:
(800) 424-9300

Non-emergency health and safety information:
(800) 545-6258.

1

Instructions for using a heat gun or torch:

- Read important warnings on page 1 and follow safety precautions provided with heat gun or torch.
- When using a torch use a soft yellow, low-heat flame. Apply just enough heat to do the job.
- Keep torch or heat gun moving continuously to distribute the heat evenly to avoid overheating, blistering or charring the heating cable and heat-shrinkable tubes.
- Replace any heat-damaged parts.

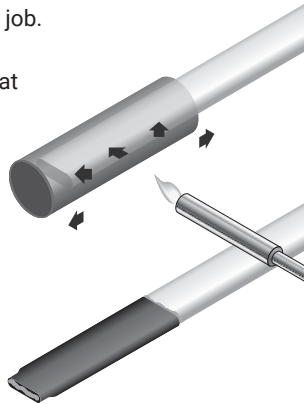

2

- Slide tubes over the heating cable as shown.
- Place one heat-shrinkable tube over each end of the expansion tube.

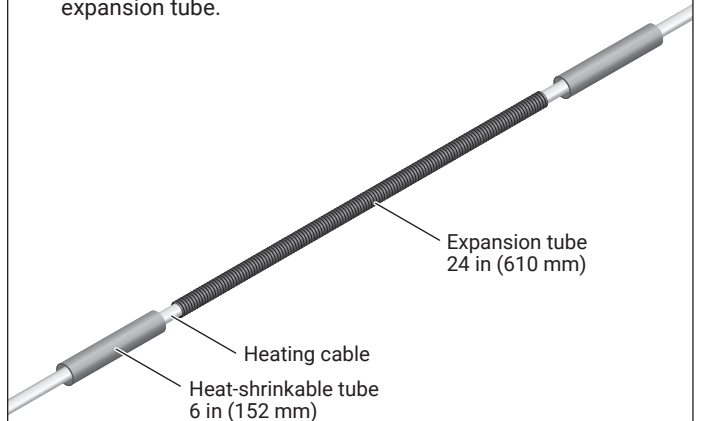

3

- Shrink tubes into position until adhesive flows out ends.
- Allow assembly to cool before installing the expansion loop.

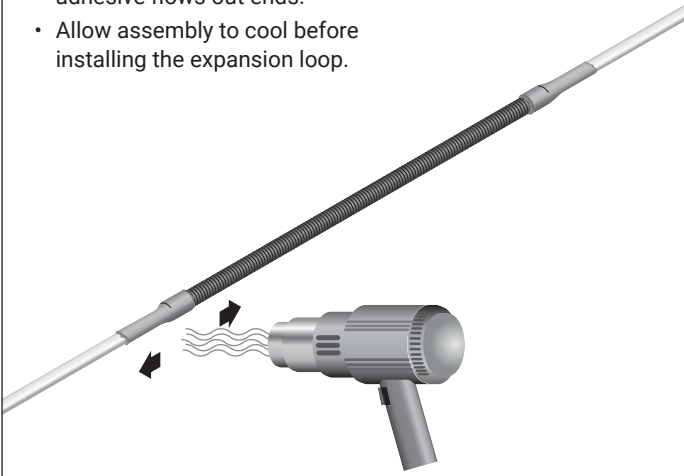

4

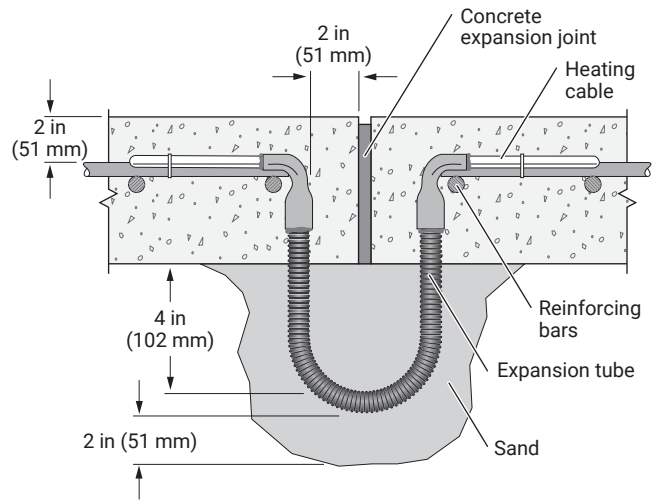

North America

Tel +1.800.545.6258
 Fax +1.800.527.5703
 thermal.info@nvent.com



nVent.com