

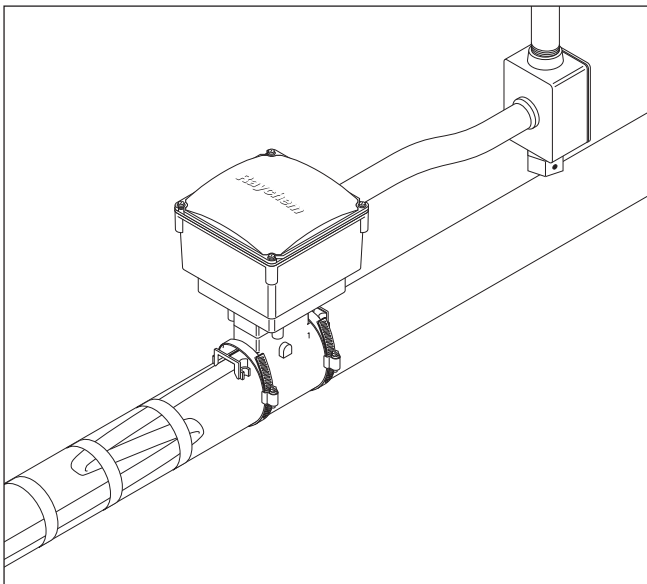

RAYCHEM

AM-BC-III-M-RT

AutoMatrix Monitor Wire Power Connection Kit Installation Instructions



DESCRIPTION

The nVent RAYCHEM AM-BC-III-M-RT is a copper-free aluminum (maximum 0.4% copper) power connection kit that can be used with RAYCHEM monitor wire self-regulating heating cables (-MCT).

For additional technical support call (800) 545-6258.

The kit contains materials for one power connection.

TOOLS REQUIRED

- Screwdriver
- Diagonal cutters
- Utility knife
- 1/4 in. nut driver
- Measuring tape
- Heat gun or torch (RAYCHEM HA-501A or equal)
- Wire strippers
- Needle-nose pliers
- Panduit CT-100 crimp tool
- 3/8 in. nut driver

ADDITIONAL MATERIALS REQUIRED

(NOT PROVIDED IN THIS KIT)

- Pipe straps
- Grommets⁽¹⁾

⁽¹⁾ See selection chart, step 1.

Kit Contents

Item	Qty	Description
A	1	Connection box assembly
	1	Connection box lid
	1	Lid gasket
	1	Connection box
	1	Pressure plate
	1	Base gasket
	1	Connection base
	10	Connection box screws
B	1	Grounding locknut (green)
C	2	Pressure plate screws (1 in. SS)
D	1	Terminal block assembly
E	1	Green/yellow heat-shrinkable tube, 1/4 in. x 6 in.
F	2	Black heat-shrinkable tube, 1/8 in. x 6 in.
G	1	Clear yellow heat-shrinkable tube, 1/2 in. x 1 in.
H	1	Clear yellow heat-shrinkable tube, 3/4 in. x 1 in.
I	1	Uninsulated ring terminal
J	3	Insulated ring terminals
K	1	Blank grommet

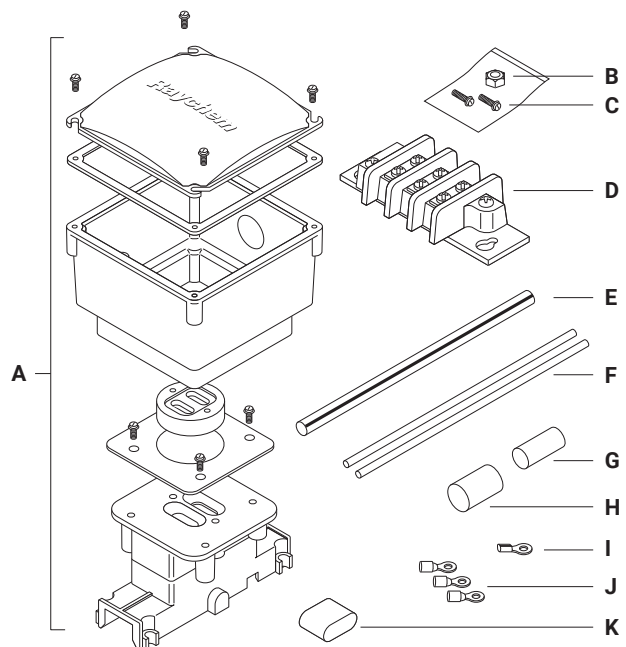

⚠ WARNING:

This component is an electrical device which must be installed correctly to ensure proper operation and to prevent shock or fire. Read these important warnings and carefully follow all the installation instructions.

- To minimize the danger of fire from sustained electrical arcing if the heating cable is damaged or improperly installed, and to comply with the 1996 National Electrical Code, ground fault equipment protection must be used on each heating cable branch circuit. Arcing may not be stopped by conventional circuit breakers.
- Component approvals and performance are based on the use of specified parts only. Do not use substitute parts or vinyl electrical tape.

⚠ CAUTION:

HEALTH HAZARD: Overheating heat-shrinkable tubes will produce fumes that may cause irritation. Use adequate ventilation and avoid charring or burning. Consult MSDS RAY3122 for further information. CHEMTREC 24-hour emergency telephone: (800) 424-9300
Non-emergency health and safety information: (800) 545-6258

- The black heating cable core and fibers are conductive and can short. They must be properly insulated and kept dry.
- Damaged bus wires can overheat or short. Do not break bus wire strands when scoring the jacket or core.
- Heat damaged components can short. Use a heat gun or a torch with a soft, yellow, low-heat flame, not a blue focused flame. Keep the flame moving to avoid overheating, blistering, or charring the heat-shrinkable tubes. Avoid heating other components. Replace any damaged parts.

1

- Identify heating cable type.
- Select correct grommet from chart on right.

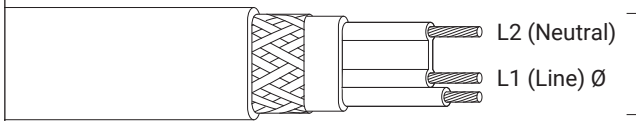

BTV-MCT and QTVR-MCT heating cables with braid and outer jacket

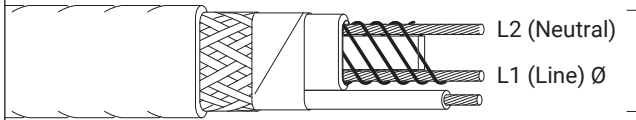

XTV-MCT heating cables with braid and outer jacket

Heating Cable Grommet*

5BTV1-MCT	N
5BVT2-MCT	N
10BVT1-MCT	F
10BTV2-MCT	F
10QTVR1-MCT	G
10QTVR2-MCT	G
20QTVR1-MCT	F
20QTVR2-MCT	F
5XTV1-MCT	N
5XTV2-MCT	N
10XTV1-MCT	N
10XTV2-MCT	N
15XTV1-MCT	N
15XTV2-MCT	N
20XTV1-MCT	N
20XTV2-MCT	N

* Must be ordered separately

⚠ WARNING: Use of the wrong grommet can result in leaks, cracked components, shock or fire, and will invalidate approvals and certifications.

2

- Allow extra heating cable for service loop as shown. Not recommended for temperature sensitive fluids or pipes less than 1 in. diameter.

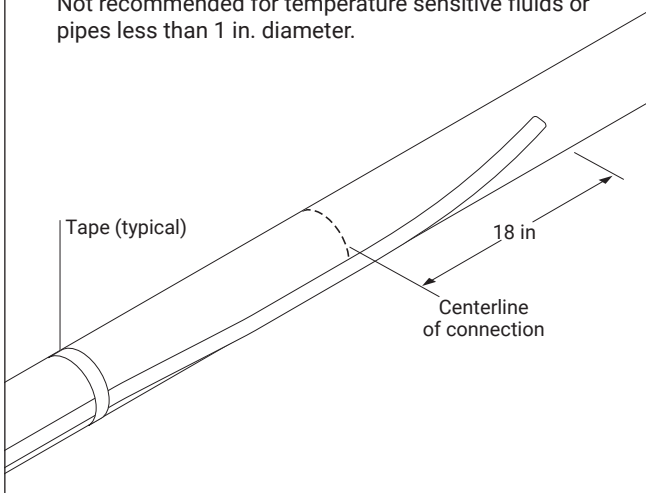

3

- Slide parts onto heating cable.

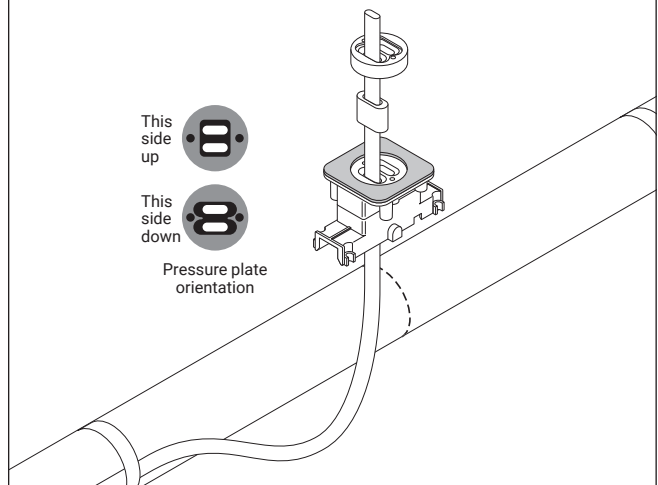

BTV-MCT and QTVR-MCT heating cables only. For XTV-MCT heating cables go to step 4B to 12B on Page 4.

4A

- Lightly score completely around and then down outer jacket.
- Bend heating cable to break jacket at score then peel off outer jacket.

Do not cut braid or inner jacket

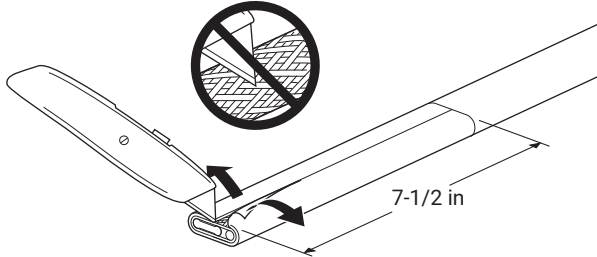

5A

- Push braid back to create a pucker.
- Open braid at pucker using screwdriver.

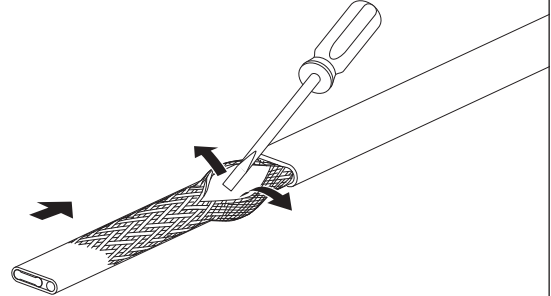

6A

- Use a screwdriver to pull heating cable through opening in braid.

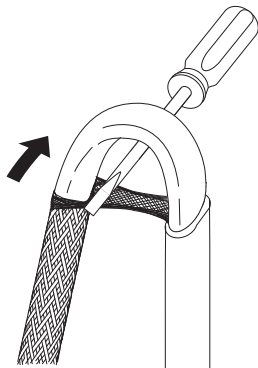

7A

- Pull braid tight

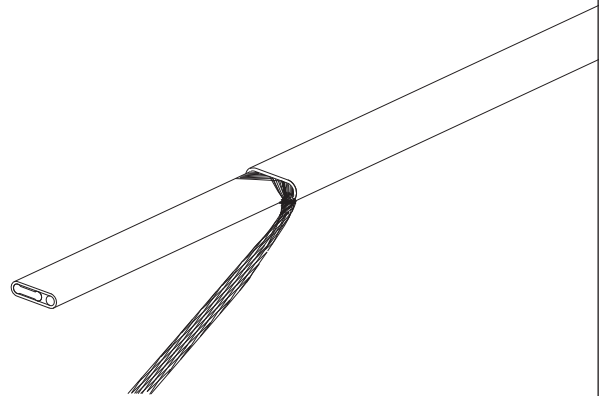

8A

- On each side of heating cable section lightly score across then down inner jacket as shown. **Do not score over monitor wire. Do not score completely around cable.**

Score jacket directly over heating cable section (both sides)

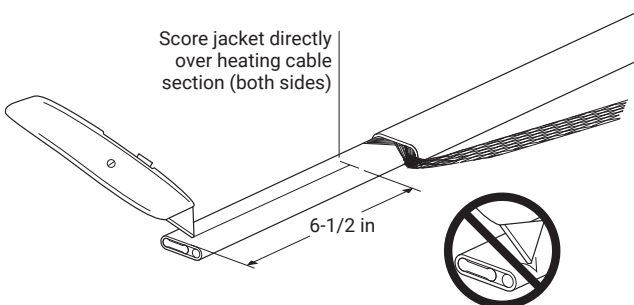

9A

- Bend heating cable to break jacket at score then peel back inner jacket.

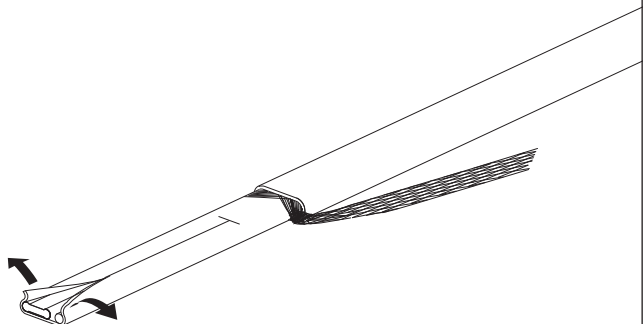

10A

- Use diagonal cutters to trim away inner jacket on each side of heating cable.

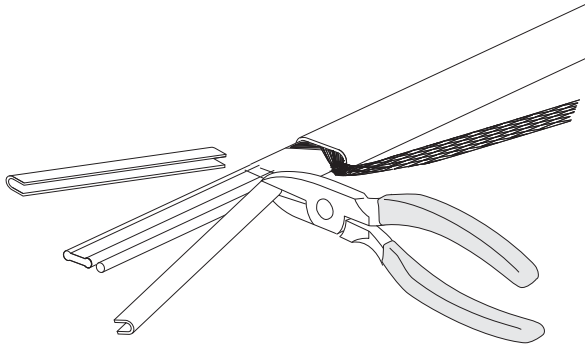

11A

- Notch core
- Twist back and peel bus wire from core.

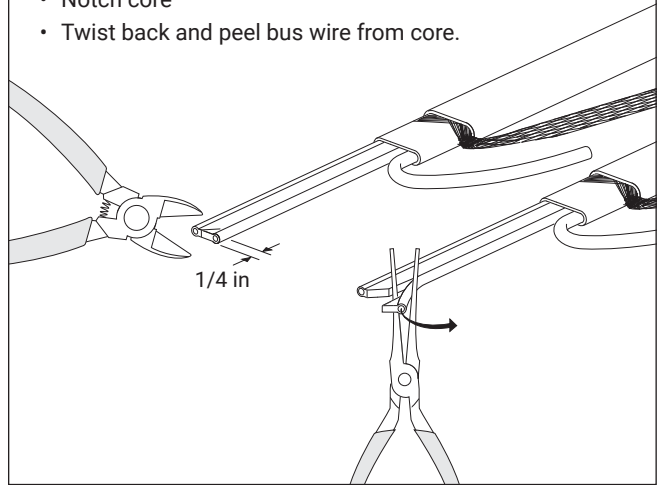

12A

- Bend and snap core.
- Peel core free from bus wire.
- Clean bus wires.

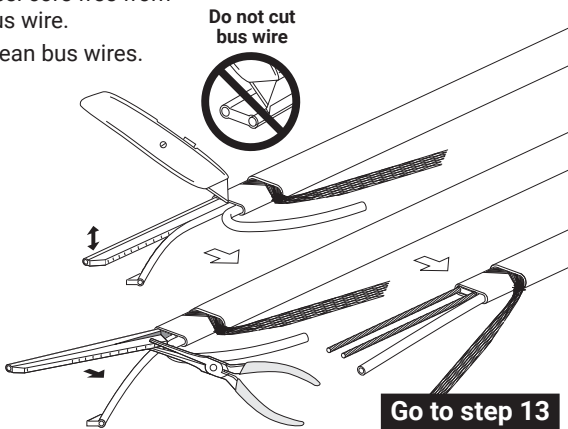

For XTV-MCT cables only.

4B

- Lightly score completely around and then down outer jacket.
- Bend heating cable to break jacket at score then peel off outer jacket.

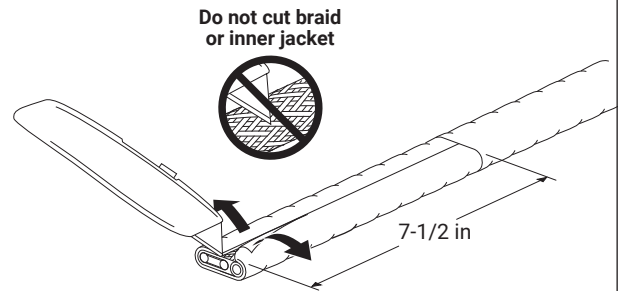

5B

- Push braid back to create a pucker.
- Open braid at pucker using screwdriver.

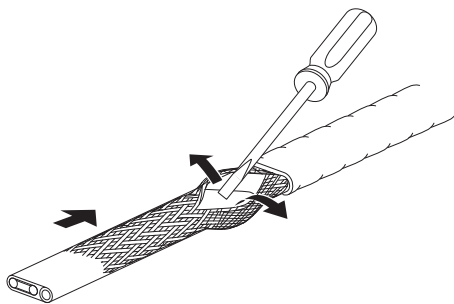

6B

- Use a screwdriver to pull heating cable through opening in braid.

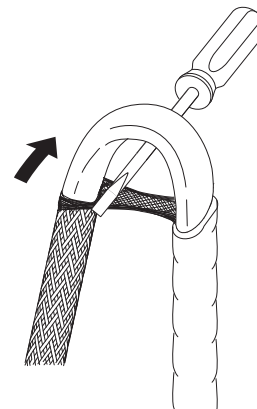

7B

- Pull braid tight.
- Remove clear plastic wrap.

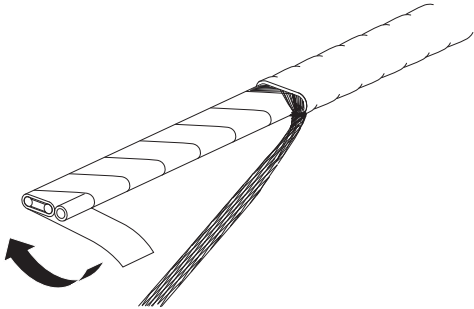

8B

- On each side of heating cable section lightly score across then down inner jacket as shown. Do not score completely around cable.

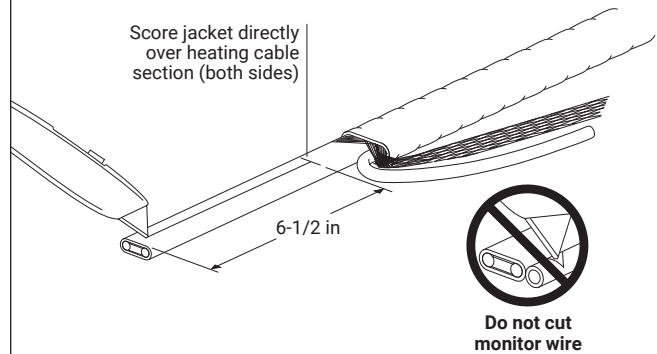

9B

- Bend heating cable to break jacket at score then peel back inner jacket.

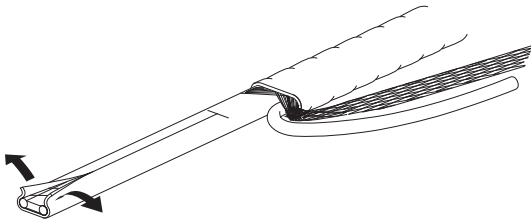

10B

- Use diagonal cutters to trim away inner jacket on each side of heating cable.

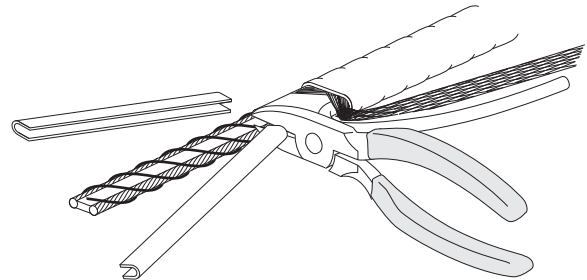

11B

- Cut off conductive fibers

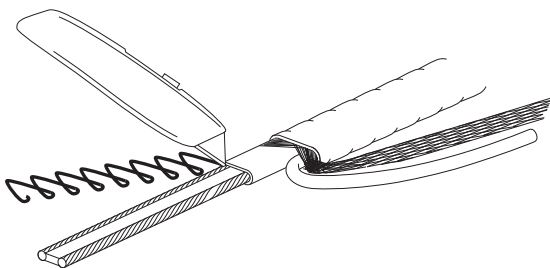

12B

Do not cut wires

- Score and remove center spacer

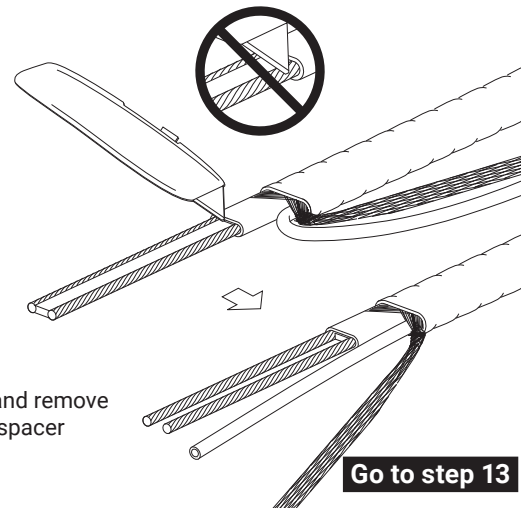

13

- Remove 1/4 in. insulation from end of monitor wire.

Do not cut wire strands

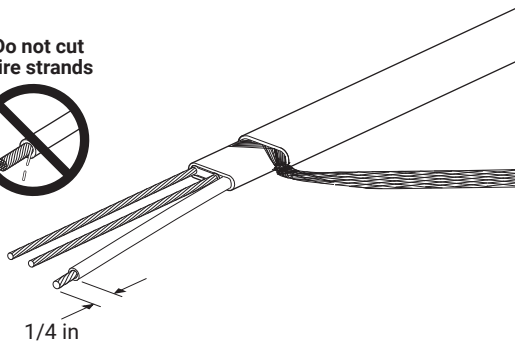

14

- Slide on 6 in. long heat-shrinkable tubes.
- Use heat gun or minitorch with soft yellow flame to gently heat tubes until they shrink.

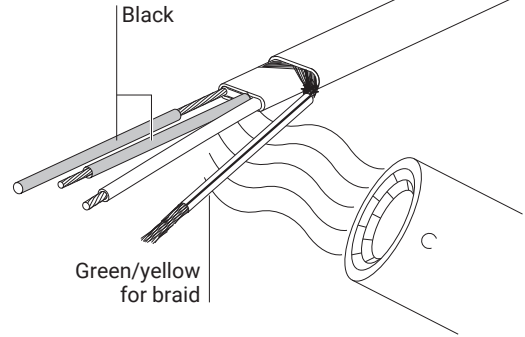

15A For BTV-MCT and QTVR-MCT heating cables only.

- Slide 3/4 in. X 1 in. clear heat-shrinkable tube over bus wires and monitor wire then position as shown.
- Gently heat tube until it shrinks and adhesive flows out ends.
- While still hot pinch between bus wires and hold for at least 5 seconds to seal. Pull aside monitor wire and pinch between bus wire and monitor wire and hold for at least 5 seconds.

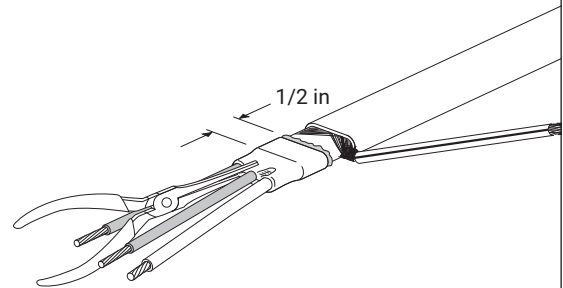
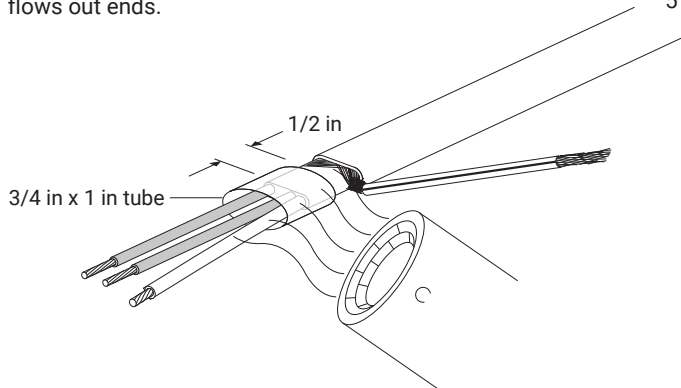

Go to step 16

15B For XTV-MCT cables only.

- Slide 1/2 in. X 1 in. clear heat-shrinkable tube over bus wires and position as shown.
- Gently heat tube until it shrinks and adhesive flows out ends.
- While still hot pinch between bus wires and hold for at least 5 seconds to seal.

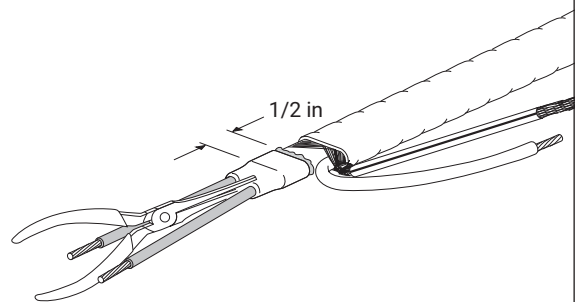
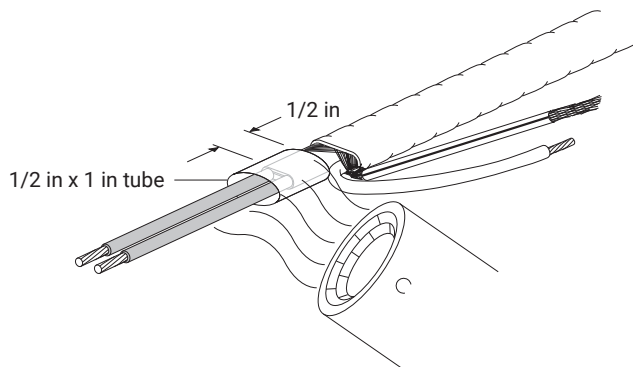

Go to step 16

16

- Trim bus wires and braid to 1/4 in..

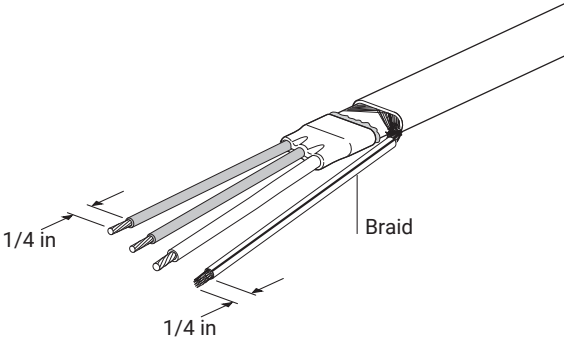

17

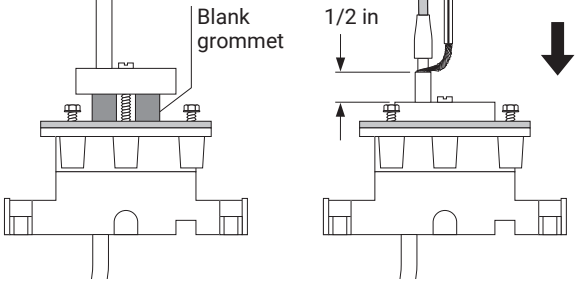

- Install blank grommet.
- Start pressure plate screws but do not tighten.
- Pull heating cable thru base and position as shown.
- Tighten pressure plate screws.

18

- Attach connection box base to pipe with pipe straps. Loop and tape extra heating cable to pipe.

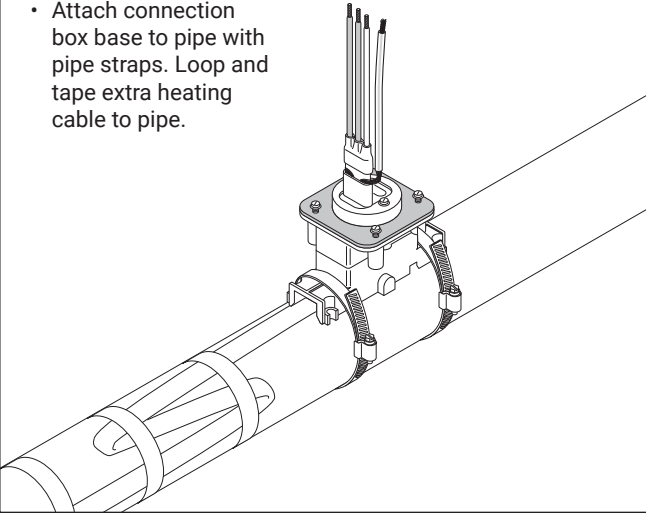

19

- Use CT-100 crimp tool to crimp on ring terminals.

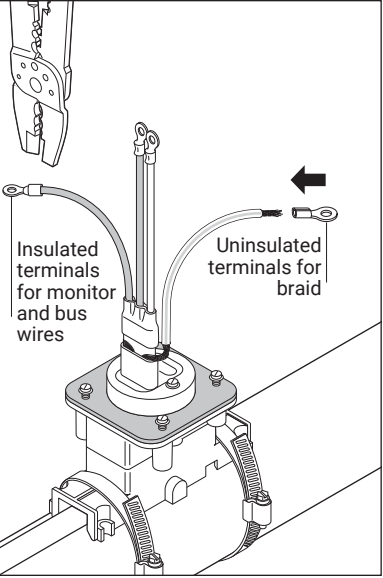

20

- Install junction box over heating cable.
- Tighten base plate screws.

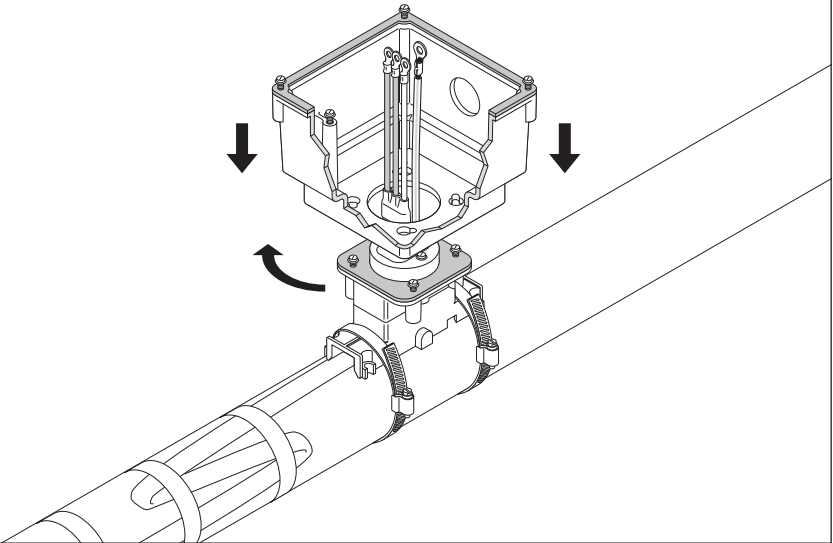

21

- Connect monitor and bus wires to terminal block.
- Connect braid wire to grounding post on terminal block bracket.

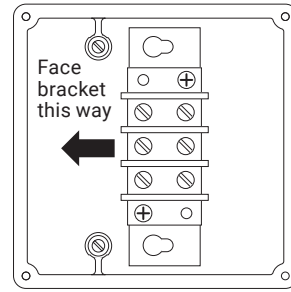
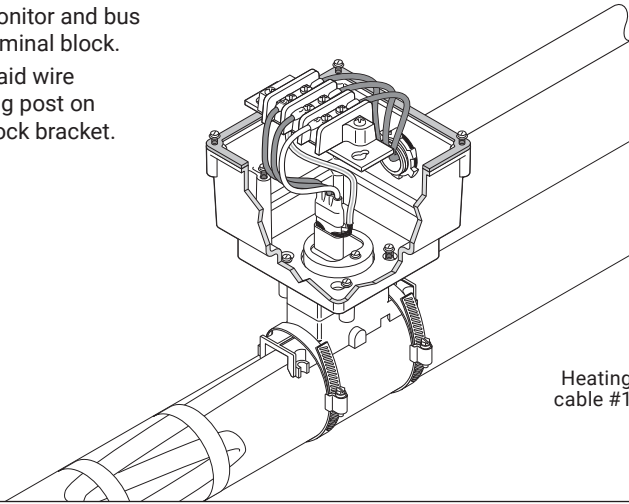

AM-BC-III-M-RT connection diagram

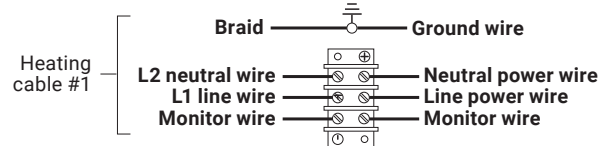

22

- Position terminal block bracket into box. Slide into place and tighten screws.
- Place lid onto box and tighten screws.

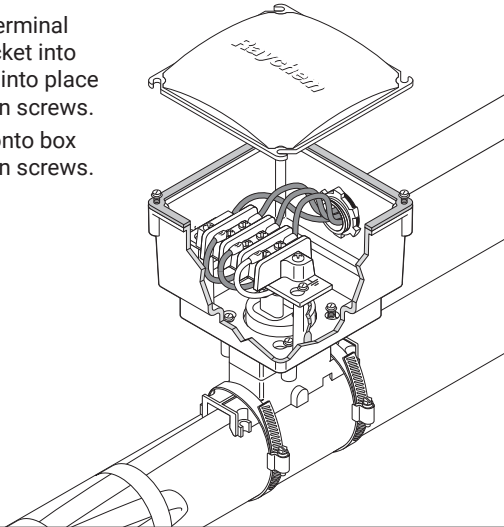

23

- Use conduit drain to prevent condensation and water buildup.

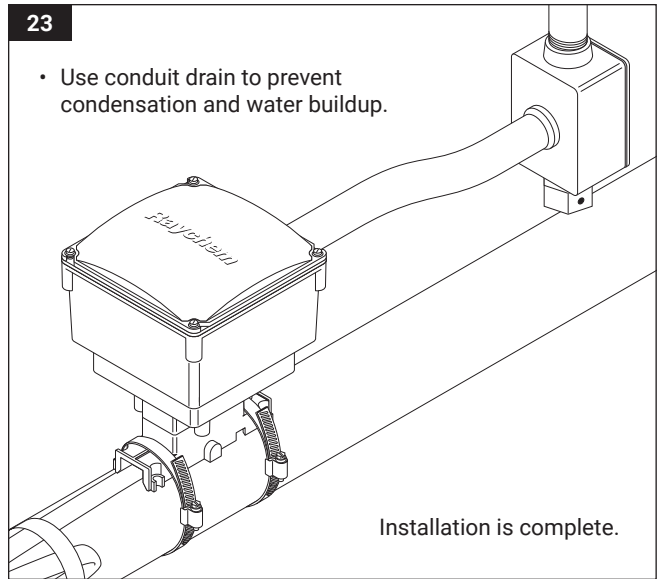

Installation is complete.

North America
 Tel +1.800.545.6258
 Fax +1.800.527.5703
 thermal.info@nvent.com

Europe, Middle East, Africa
 Tel +32.16.213.511
 Fax +32.16.213.604
 thermal.info@nvent.com

Asia Pacific
 Tel +86.21.2412.1688
 Fax +86.21.5426.3167
 cn.thermal.info@nvent.com

Latin America
 Tel +1.713.868.4800
 Fax +1.713.868.2333
 thermal.info@nvent.com



nVent.com