



RAYCHEM

SNOW OWL

Aerial General-Purpose Snow Sensor

Installation Instructions





FEATURES

- Reduced energy consumption with automatic snow melting.
- Slim design minimizes visual impact.
- Mounts on 3/4" PVC or 1/2" PVC with optional reducing bushing or 1/2" NPT with included fittings.
- Operates on safe low voltage power.
- Simple 3 wire connections, 2 power, one signal.
- Drop in replacement for ETI's CIT-1 aerial sensor
- Convenient power-on self-test to verify proper sensor operation
- Housing made with ASA UV-resistant plastic that was formulated by the auto industry for exterior plastic trim
- Made in the USA

FEATURES

Dimensions	Height: 3.75" Diameter: 1.75"
Input Power	24 V AC 50/60 Hz or 24 V DC or 24 V full wave rectified AC/Pulsed DC 0.2A max
Output	Relay Contacts: 2 Amps max, 30 V
Hold-on Time	Zero hold on time
Operating Temperature	-40°C to +85°C (-40°F to +185°F)
Temperature Set Point	38°F
Storage Temperature	-40°C to +85°C (-40°F to +185°F)

SAFETY

Make all electrical connections in compliance with the National Electrical Code (NFPA 70) and the local electrical code.

ABNORMAL ODOR OR SMOKE

In the event of smoke, a burning odor or abnormal odor, immediately interrupt power to the unit by unplugging the unit or by turning off the circuit breaker protecting the unit.

ELECTRICAL SHOCK/FIRE HAZARD

As a low voltage control the SNOW OWL has a maximum current load of 2 amps resistive for 24 VAC and presents little hazard of electrical shock or fire. The SNOW OWL is intended to control higher voltage/current heating circuits which can present such hazards so care must be taken when using the sensor for these applications. This product is intended for residential or light commercial applications. Any installation involving electric heaters must be grounded to earth to protect against shock and fire hazard. Use a suitably sized ground fault detection and interruption system to reduce shock and fire hazard and to protect equipment. Wiring to heating elements must be installed in accordance with the National Electrical Code (NEC) requirements and all other local and applicable electrical codes and any third party standards. Follow the installation instructions contained in this manual and those provided by the heater manufacturer.

Use a GFEP (Ground Fault Equipment Protection) circuit breaker on each branch circuit connected to the ice melting system. Clearly label each circuit breaker with its function. This is vitally important when there is more than a single point of disconnect. Size the circuit breaker in accordance with the size of the maximum expected load.

Make certain that the heater shield is properly grounded. Failure to do so may result in electrical shock, damage to equipment or fire. The Snow Owl performs an internal self test when the power is first turned on. During the first 10 seconds of power up the sensor will turn on its output for a short time and engage any contactor that is connected to it. **For this reason care should be taken to ensure that heater power is either connected properly or that it is turned off/disconnected before powering up the sensor.**

Following installation and prior to beginning system operation refer to and perform the post-installation tests described in this manual.

THEORY OF OPERATION

The SNOW OWL sensor monitors atmospheric conditions to determine when a snow/freezing rain event occurs and responds by providing a grounded output to the control circuit or contactor which in turn will enable the heating system.

It does this by using the snowflake shaped moisture sensor on the top cap to melt the snow/ice that lands on it and then detects the resulting water using a low voltage current. The detection of water alone will not provide an output but is used in combination with a temperature reading below 38°F. An Internal processor looks for this combination of moisture and temperature and triggers the output only when both conditions are present. This allows the SNOW OWL to trigger a heat cycle only when it is needed. Once the SNOW OWL has triggered it will remain on until one or both of the stimuli is removed, and it determines that the stimuli remains missing for the next 4 minutes.

INSTALLATION INSTRUCTIONS

With user supplied hardware, mount the SNOW OWL securely in an upright position (sensor snowflake at top) in a clear and open area typical of the area to be melted, either above the roof line or removed from the building in an area exposed to falling snow.

- Avoid overhead trees, shrubs, wires, eaves, etc., and falling or blowing debris.
- Avoid vehicle and foot traffic. Avoid creating a tripping or safety hazard.
- Avoid exposure to artificial heat sources and excessive shock and vibration.
- Position the sensor at a height to reduce, eliminate or discourage damage caused by animals or vandals.

Install in accordance with the requirements of all applicable electrical and building codes and regulations. Ensure that all conduit and cable terminations are watertight. NEC Article 426.28 requires equipment ground fault protection (GFEP) for ice and snow melting equipment. This functionality is not provided as part of this sensor and must be provided as part of the overall system. The SNOW OWL can be mounted at a distance up to 500 feet away from the controller or contactor using 22-gauge wires and up to 1000 feet using 18 gauge wires. Once the SNOW OWL has been mounted in the desired location it can be connected to the controller or contactor.

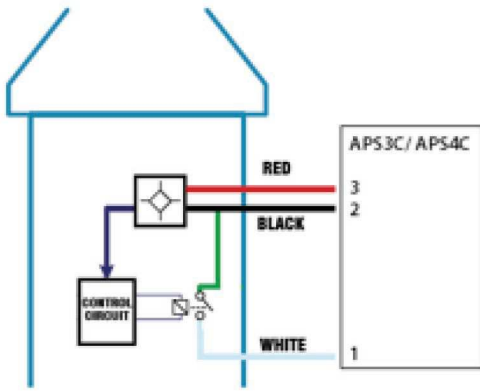

APS-3/4 CIT-1 Drop in Replacement

POWER ON SELF TEST PREINSTALLATION TEST

The SNOW OWL performs an internal self test when the power is first turned on. During the first 10 seconds of power up the sensor will turn on its output and engage any contactor that is connected to it for a short time. For this reason care should be taken to ensure that heater power is either connected properly or that it is turned off/disconnected before powering up the sensor. If the sensor gives a continuous ON-OFF-ON-OFF output then this is an indication of a bad sensor. As a pre installation test the POST can be run simply by powering the unit and observing the output.

INSTALLATION DIAGRAMS

The following diagrams show the SNOW OWL and CIT -1 drop in installations

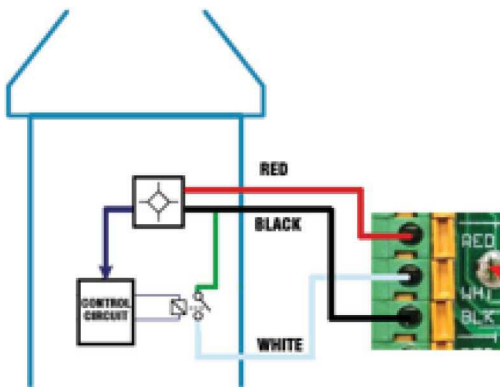

Pro Series CIT-1 drop in replacement

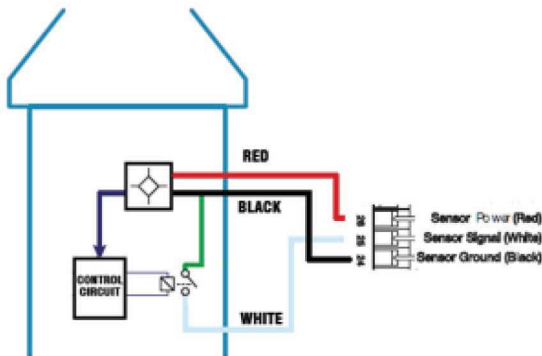

EUR-5A CIT-1 drop in replacment



TESTING AFTER INSTALLATION

After installation the sensor can be tested by cooling the sensor base with either ice (do not immerse the sensor in ice water, it is not water proof.) or freeze mist. Locate the internal temperature sensor by first locating the indexing tab (in the red circle in picture below) and apply the mist to the base of the sensor on the opposite side of the indexing tab.

Once the unit is cooled continue by placing a drop of water on the moisture grid. If testing in the winter and the temperature is below 3.3°C (38°F) then simply placing a drop of water or a small amount of snow on the moisture grid will start a heating cycle. To stop the cycles simply turn off the power for 5 to 10 seconds and then turn it back on.

LIMITED WARRANTY

This product is covered by a one (1) year limited warranty for materials and workmanship. The warranty starts from date of manufacture and extends for one (1) year. For users who complete the enclosed warranty card and return it to the manufacturer as directed, the warranty will be extended to two (2) years from date of purchase.



North America

Tel +1.800.545.6258

Fax +1.800.527.5703

thermal.info@nVent.com



nvent.com/RAYCHEM

©2020 nVent. All nVent marks and logos are owned or licensed by nVent Services GmbH or its affiliates. All other trademarks are the property of their respective owners. nVent reserves the right to change specifications without notice.

RAYCHEM-IM-H60980-ETISnowOwl-EN-2012