

THIS COPY IS PROVIDED ON A RESTRICTED BASIS AND IS NOT TO BE USED IN ANY WAY DETRIMENTAL TO THE INTERESTS OF PANDUIT CORP.

PANDUIT PART NUMBER	WIRE RANGE (AWG)	STUD SIZE S	DIMENSIONS			MAX WIRE INSUL. DIA	R MIN WASHER RADIUS	INSUL. COLOR	PKG QTY
			B ±.01" (±.25)	W ±.01" (±.25)	L (min.)				
PH18-6R	22-18	#6	.250 (6.35)	.25 (6.35)	1.05 (26.67)	.170 (4.32)	.130 (3.30)	RED	25
PH18-8R	22-18	#8	.250 (6.35)	.31 (7.87)	1.08 (27.43)	.170 (4.32)	.140 (3.56)	RED	25
PH18-10R	22-18	#10	.250 (6.35)	.31 (7.87)	1.08 (27.43)	.170 (4.32)	.172 (4.37)	RED	25
PH18-14R	22-18	1/4"	.250 (6.35)	.47 (11.94)	1.24 (31.50)	.170 (4.32)	.290 (7.37)	RED	25
PH14-6R	16-14	#6	.250 (6.35)	.31 (7.87)	1.06 (26.92)	.190 (4.83)	.130 (3.30)	BLUE	25
PH14-8R	16-14	#8	.250 (6.35)	.31 (7.87)	1.03 (26.16)	.190 (4.83)	.140 (3.56)	BLUE	25
PH14-10R	16-14	#10	.250 (6.35)	.32 (8.12)	1.05 (26.67)	.190 (4.83)	.172 (4.37)	BLUE	25
NCPH14-10R	16-14	#10	.250 (6.35)	.32 (8.12)	1.05 (26.67)	.190 (4.83)	.172 (4.37)	BLUE	500
PH14-14R	16-14	1/4"	.250 (6.35)	.46 (11.68)	1.24 (31.50)	.190 (4.83)	.290 (7.37)	BLUE	25
PH14-56R	16-14	5/16"	.250 (6.35)	.46 (11.68)	1.24 (31.50)	.190 (4.83)	.290 (7.37)	BLUE	25
PH14-38R	16-14	3/8"	.250 (6.35)	.53 (13.46)	1.24 (31.50)	.190 (4.83)	.290 (7.37)	BLUE	25
PH10-8R	12-10	#8	.250 (6.35)	.37 (9.40)	1.22 (30.99)	.240 (6.10)	.140 (3.56)	YELLOW	20
PH10-10R	12-10	#10	.250 (6.35)	.37 (9.40)	1.20 (30.48)	.240 (6.10)	.172 (4.37)	YELLOW	20
NCPH10-10R	12-10	#10	.250 (6.35)	.37 (9.40)	1.20 (30.48)	.240 (6.10)	.172 (4.37)	YELLOW	200
PH10-14R	12-10	1/4"	.250 (6.35)	.52 (13.21)	1.20 (30.48)	.240 (6.10)	.290 (7.37)	YELLOW	20
NCPH10-14R	12-10	1/4"	.250 (6.35)	.52 (13.21)	1.20 (30.48)	.240 (6.10)	.290 (7.37)	YELLOW	200
PH10-38R	12-10	3/8"	.250 (6.35)	.59 (14.99)	1.20 (30.48)	.240 (6.10)	.290 (7.37)	YELLOW	20
PH10-12R	12-10	1/2"	.250 (6.35)	.72 (18.29)	1.54 (39.12)	.240 (6.10)	.350 (8.89)	YELLOW	20

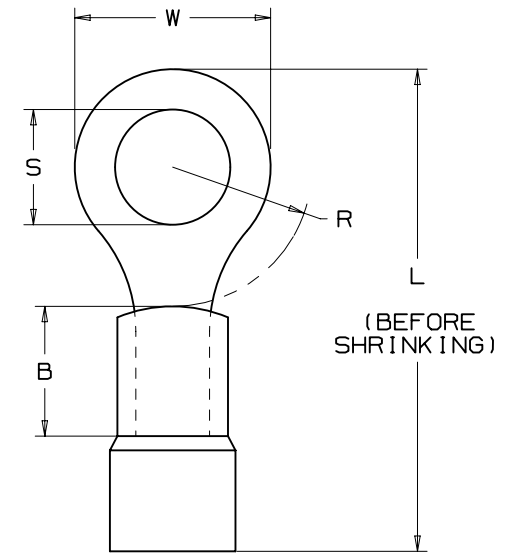

UL LISTED 1200 E52164

- NOTES:
- UL LISTED AFTER HEAT SHRINKING FOR:
 - A. 600 V. MAX. VOLTAGE RATING
 - B. 257°F (125°C) MAX. TEMPERATURE RATING.
 - MATERIAL:
 - A. TERMINAL- TIN PLATED COPPER WITH BRAZED SEAM.
 - B. INSULATOR- HEAT SHRINKABLE POLYOLEFIN WITH HOT MELT SEALANT.
 - MINIMUM SHRINK TEMPERATURE: 300°F (150°C)
 - ALL DIMENSIONS SHOWN ARE NOMINAL.
 - INSTALLATION TOOL: CT-310
 - WIRE STRIP LENGTH: 5/16" ¹/₁₆ (7.9^{±.6})

08A	7-14-23	JHNU	JHNU	MRWA	A. REMOVED CSA SYMBOL	132310
07	8-25-16	TMR	TMR	RGB	UPDATED TONGUE WIDTH TOLERANCE FROM .005" TO .01"	A41456
06	04-26-13	JBN	RTFI	RTFI	UPDATED DRAWING BORDER & TITLE BLOCK	A41456

TITLE		RING TERMINALS, HEAT SHRINK INSULATED	
CUSTOMER DRAWING			
ITEM REVISION NAME	N41456BA/08	PANDUIT	
DATASET FILE NAME	N41456BA_DC/08A		
UNLESS OTHERWISE SPECIFIED, DIMENSIONAL TOLERANCES ARE: IN [mm]		MATERIAL:	
.x ± .1 [2.54] .xxx ± .005 [.127]		SEE NOTES	
.xx ± .01 [.25] ANGLES ± 5 °		DRAWING NUMBER:	
THIRD ANGLE PROJECTION		A41456	
DRAWN BY	DATE	CHK	SCALE
DRL	-	-	NONE
SHT 1 OF 1		A	

D101000A/15