

PanZone® Category 6A STP Cable Assemblies

SPECIFICATIONS

Zone cabling assemblies shall be constructed of Category 6A 23 AWG, solid, shielded, F/UTP, twisted pair cable and available in plug-to-plug or jack-to-plug termination configurations. Cable assemblies shall be available in Low Smoke Zero Halogen (LSZH), Plenum or Riser flammability ratings and shall be wired according to T568B guidelines. A variety of lengths shall be available for design flexibility.



TECHNICAL INFORMATION

Category 6A/Class E_A channel and permanent link performance:	Exceeds all ANSI/TIA-568.2-D Category 6A and ISO 11801 Class EA channel and permanent link standards requirement
FCC and ANSI compliance:	Meets ANSI/TIA-1096-A requirements; contacts plated with 50 micro inches of gold for superior performance
IEC compliance:	Meets IEC 60603-7; IEC 60754-1
PoE compliance:	Meets IEEE 802.3af and IEEE 802.3at for PoE applications
c(UL)us compliance:	UL 1863, CSA Standard C22.2
RoHS compliance:	Compliant
Cable diameter:	0.29 in. (7.4mm) nominal
Operating temperature:	14°F to 167°F (-10°C to 75°C)
Installation temperature:	-40°F to 158°F (-40°C to 70°C)
Flammability rating:	Plenum, Riser, or LSZH

KEY FEATURES AND BENEFITS

100% Performance tested:	Confidence that each cable assembly delivers Category 6A permanent link performance
Patented tangle-free latch:	Prevents snags and provides easy release, saving time on frequent moves, adds, and changes
Robust construction:	Plug contact plated with 50 microinches of gold and rated to 2500 mating cycles
Flexible stranded cable:	U/UTP stranded 28 AWG copper cable with a nominal diameter of 0.149 in. (3.8mm) allows for high density installations and superior panel cable management
Color bands (optional):	Snap onto cable, allowing additional color coding options
RJ45 plug lock-in device (optional):	Secures plug into jack to prevent unauthorized removal of patch cord

APPLICATIONS

Zone cabling products are designed to provide an efficient and cost effective way to design and deploy cabling systems in data centers and open office architecture environments. Each zone cabling product serves as a main distribution point for a particular zone, increasing network flexibility, manageability, accessibility, and efficiency. Utilizing a distributed network and a zone cabling topology for physical infrastructure can reduce telecommunication congestion. Zone cabling products accommodate multimedia solutions and can be used in floor, ceiling, and all mount applications, which provide a complete end-to-end network solution. Zone cabling topology provides a scalable physical network infrastructure that meets the needs of today as well as the flexibility to deploy technology of tomorrow.

PanZone Category 6A STP Cable Assemblies

LSZH:	SAPLWH*M
Riser:	SAPRBU100

*Meter Lengths: 10, 20, 30, 40 meters



PanZone® Category 6A STP Cable Assemblies are pre-labeled with the RapidID™ Network Mapping System to enable faster tracing, placing, and network documentation. Learn more: www.panduit.com/rapid-id



All Part Numbers Compliant with the U.S. Trade Agreements Act (TAA) for purchases shipped to the United States.

PanZone® Category 6A STP Cable Assemblies

ENGINEERING DRAWINGS

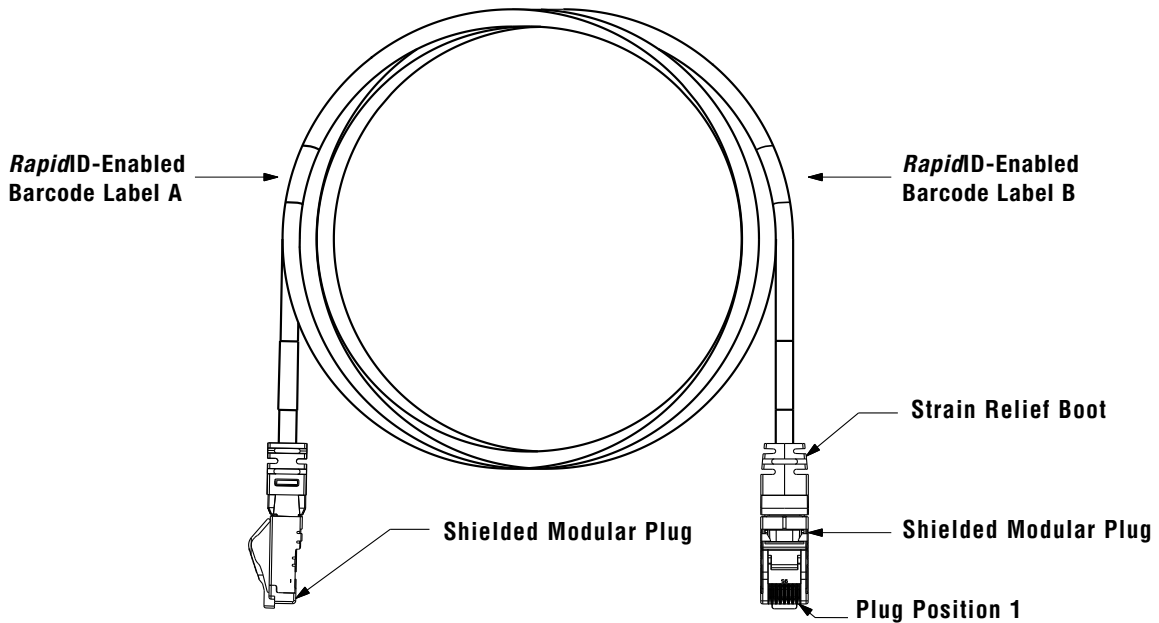
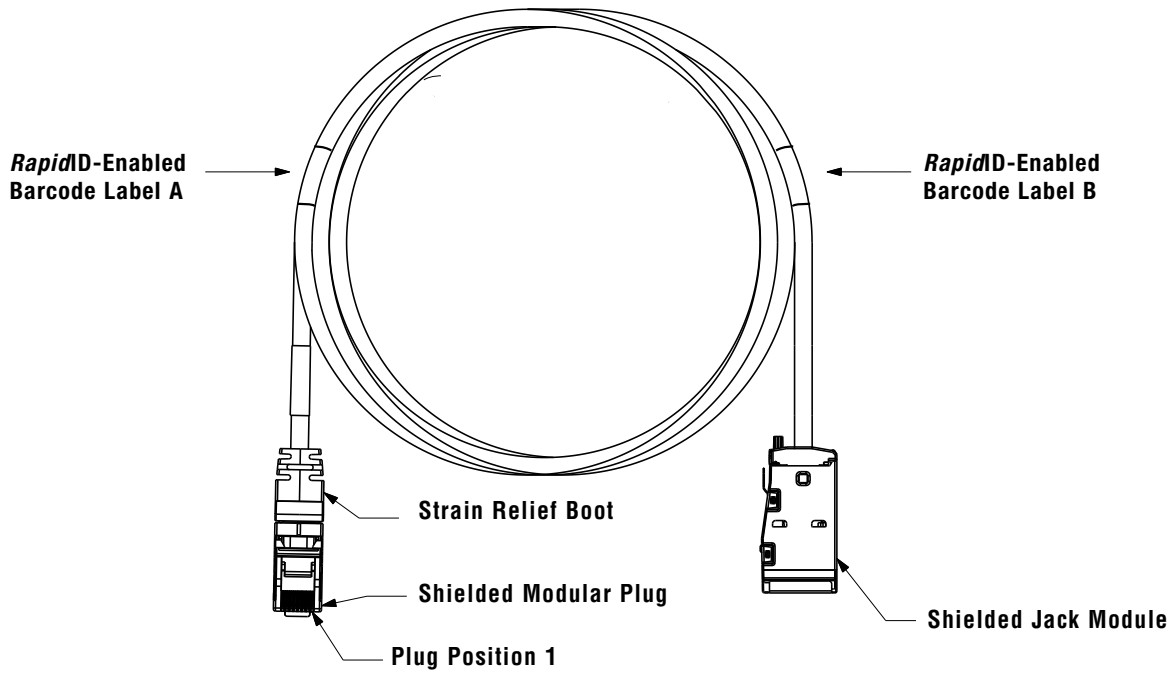

Dimensions are in inches. [Dimensions in brackets are metric].

WORLDWIDE SUBSIDIARIES AND SALES OFFICES

PANDUIT US/CANADA
Phone: 800.777.3300

PANDUIT EUROPE LTD.
London, UK
Phone: 44.20.8601.7200

PANDUIT SINGAPORE PTE. LTD.
Republic of Singapore
Phone: 65.6305.7575

PANDUIT JAPAN
Tokyo, Japan
Phone: 81.3.6863.6000

PANDUIT LATIN AMERICA
Guadalajara, Mexico
Phone: 52.33.3777.6000

PANDUIT AUSTRALIA PTY. LTD.
Victoria, Australia
Phone: 61.3.9794.9020

For a copy of Panduit product warranties, log on to www.panduit.com/warranty

PANDUIT®

For more information
Visit us at www.panduit.com
Contact Customer Service by email: cs@panduit.com
or by phone: 800.777.3300

© 2023 Panduit Corp.
ALL RIGHTS RESERVED.
COSP324-WW-ENG
10/2023