

LUNA

4" Regressed Gimbal, 700 Lumens, 9-12 Watts,
Dim-to-Warm
Recessed Downlighting

Job Information		
Project Name		Type
Location		
Quantity		Date
Contact/Phone		
Notes		

Features

Body

Durable airtight aluminum body with adjustable regressed gimbal. Includes anodized blue heat sink to provide maximum airflow for the LED light source.

LED Characteristics

This general application light fixture features an LED module that maintains uniform intensity producing up to 700 lumens; with a typical CRI of 90. Available in 3000 K color temperatures.

Dimming

Color temperature dimming from 3000 K to 2000 K. This fixture is compatible with industry standard forward-phase / reverse-phase and TRIAC/ELV dimmers (contact factory for list of compatible dimmers).

Beam Spread

The fixture lens provides 38° beam spread.

Mounting

Includes two spring loaded clips to attached to any ceiling material.

LED Driver

Extruded aluminum hardwire box with 12 watt (300mA) or 9 watt (210mA) dimmable class II electronic LED driver with 100-135V AC input. Includes an 18" FT6 rated cable with DC 2.1 connector between driver and fixture approved for use in plenums and suspended ceilings.

Quick Connect push-in terminals

Three "Quick connect" push-in terminals for fast and easy wiring.

Operating Temperature

-20°C~40°C (-4°F~104°F)

Environment

- Suitable for wet locations.
- Approved for direct contact with insulation.
- Airtight
- Suitable for insulated ceiling applications.

Note

- Tested with insulation up to R60
- VBE recommended in spray foam

and loose fill applications

QuickShip In-Stock

In-Stock products ship within two business days of an order being released.*

SPECIFICATION	
Application	Ceiling Recess Mount
Approved Location	Wet / Insulated Ceilings
Beam Angle	38°
CCT	3000 K~2000 K
Certification	cETLus
Class II	Yes
Color	BK / BN / OB / WH
CRI	90
Dimming	Yes
Dimming Tech	Forward/reverse-phase TRIAC/ELV
Hole Cut	Ø 4 1/4" (108mm)
Input	100-135V AC, 50 / 60Hz
Lumens	Up to 700
Lumens per Watt	Up to 59
Power Factor	0.9
Projected Life	70% @ 50,000 hrs
Warranty	Lifetime
Wattage	9W / 12W



Description

Evolved to be a flexible, low-glare, and aesthetically pleasing luminaire, the LUNA Designer Series offers contractors, builders, homeowners and designers, a fixture with regressed optics abilities, to promote on-site flexibility, while enhancing sleek, directional lighting in both commercial and residential spaces.

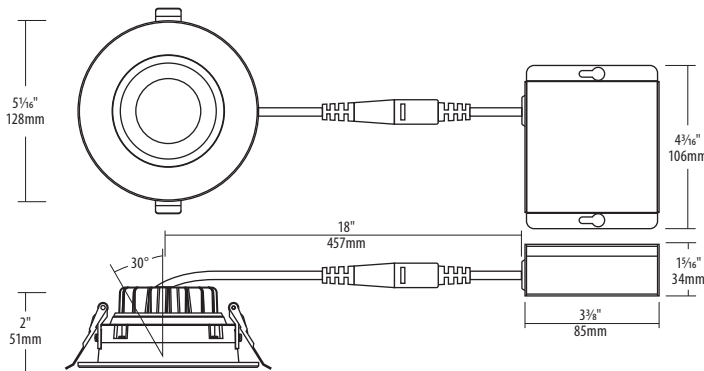

Notes: Accessories are sold separately. For additional options please consult your Liteline representative. Due to our continued efforts to improve our products, product specifications are subject to change without notice.

Ordering Guide

Wattage	Driver Options	Trim Finish
RA4 - <input type="checkbox"/> 12: 12 watt <input type="checkbox"/> 9: 9 watt 	<input type="checkbox"/> Leave blank for standard 120V driver <input type="checkbox"/> E : Lutron Hi-Lume® 1% (EcoSystem®) <input type="checkbox"/> EM : Emergency Backup, 120~277V, 0-10V <input type="checkbox"/> C : 120~347V, 0-10V	<input type="checkbox"/> BK : Black <input type="checkbox"/> BN : Brushed Nickel <input type="checkbox"/> WH : White <input type="checkbox"/> OB : Oil Rubbed Bronze

Highlighted option denotes QuickShip.

* QuickShip lead time may vary for orders greater than 100 pieces. No additional shipment rates apply. Subject to availability.

Accessories



SLM-60-FC

60" Flexible connector, for use with SlimLED fixtures.



P-4020

4 1/4" Round pre-mounting plate with driver attachment clip, for 4" LUNA LED fixtures.



P-4020NC

4 1/4" Round new construction plate with driver attachment clip, for 4" LUNA LED fixtures.



P-NCMK-1

New construction mounting kit. Includes hanger bars, brackets and screws.



RA4-XLRING-BK

Reducer ring for 4" LUNA fixtures, black.



RA4-XLRING-BN

Reducer ring for 4" LUNA fixtures, brushed nickel.



RA4-XLRING-WH

Reducer ring for 4" LUNA fixtures, white.



VBE-1

Vapour barrier extender. For use in new construction applications.



VBE-2

Vapour barrier extender. For use in remodel applications.



VBE-3

Vapour barrier extender. For use in remodel applications.



VBE-4

Vapour barrier extender. For use in remodel applications.



VBE-5

Vapour barrier extender. For use in new construction applications.



LC-CRTL-3WAY-1

OnCloud Smart Wi-Fi 3-Way Switch, compatible with WIZ App.



LC-CRTL-DIM-1

OnCloud Smart Wi-Fi dimmer, 120V, compatible with WIZ App.