

Specification Submittal Data / Panasonic Ventilation Fan (Multi-Speed module included)

Description

Customizable ceiling mount ventilating fan, low sone and rated for continuous operation. NGBS certified. ENERGY STAR[®] rated and certified by the Home Ventilating Institute (HVI). Evaluated by the Underwriters Laboratories and conforms to both UL and cUL standards.

Motor/Blower:

- Enclosed brushless ECM smart motor technology rated for continuous operation
- Adjustable ventilation rates at 30-110 CFM
- Power rating of 120 volts and 60 Hz
- UL and cUL listed for tub/shower enclosure when GFCI protected.
- Motor equipped with thermal cutoff fuse
- Removable permanently lubricated plug-in motor

Housing:

- Environmentally friendly 26 gauge housing using Zinc-Aluminum-Magnesium (ZAM) coating
- Built-in damper reduces back draft and helps with blower door testing
- Built-in metal flange provides blocking for penetrations through drywall as an Air Barrier, and assists with the decrease in leakage in the Building Envelope during blower door testing
- Suitable for installation in ceilings insulated up to R60
- Articulating and expandable installation bracket up to 24"

Grille:

- New architectural grille design complements the aesthetics of any room
- Attaches directly to housing with torsion springs
- Includes a motion sensor cap for use as a cover when the motion sensor Plug 'N Play[®] module has not been selected

Warranty:

- ECM Motor: 6 Years from original purchase date
- ALL Parts: 3 Years from original purchase date

Architectural Specifications:

Customizable ceiling mount ventilation fan with slim grille, ENERGY STAR[®] rated with built-in 110/80/50 CFM speed selector and multi-speed module for 30-110 CFM Continuous Ventilation Home Ventilating Institute (HVI) Certified at 0.1, 0.25, 0.375, and 0.5" w.g. at all speeds 30-40-50-60-70-80-90-100-110 CFM

6" Duct as Certified by the Home Ventilating Institute (HVI) – ENERGY STAR MOST EFFICIENT 2024

@ 0.1 w.g., 110/80/50 CFM with <0.3 sone and with energy efficiency no more than 15.2/17.3/15.2 CFM/Watt

@ 0.25 w.g., 111/80/50 CFM with <0.3 sone and with energy efficiency no more than 8.6/8.6/7.2 CFM/Watt

@ 0.375 w.g., 110/80/50 CFM with energy efficiency no more than 6.2/6.1/5.0 CFM/Watt

@ 0.5" w.g., 109/80/50 CFM with energy efficiency no more than 4.6/4.5/3.9 CFM/Watt

Utilizing 4" Duct with 6" to 4" reducer as Certified by the Home Ventilating Institute (HVI) –

@ 0.1 w.g., 110/80/50 CFM with <0.3 sone and with energy efficiency no more than 10.5/13.0/13.6 CFM/Watt

@ 0.25 w.g., 110/80/50 CFM with no more than 0.6/0.5/0.4 sones and with energy efficiency no more than 6.8/7.4/7.0 CFM/Watt

@ 0.375 w.g., 110/80/50 CFM with energy efficiency no more than 5.1/5.3/5.0 CFM/Watt

@ 0.5" w.g., 100/80/50 CFM with energy efficiency no more than 4.1/4.1/4.1 CFM/Watt

The motor shall be enclosed with brushless ECM motor engineered to run continuously. ECM motor speed shall automatically increase when the fan senses static pressure to maintain selected CFM. Power rating shall be 120v/60Hz. Plug 'N Play[®] modules provide additional features such Condensation Sensor, SmartAction Motion Sensor, Dual Motion Sensor + Condensation Sensor and Wi-Fi Module. Fan shall be RoHS Compliant and UL and cUL listed for tub/shower enclosure when GFCI protected. Also suitable for installation in ceilings insulated up to R60. Fan can be used to comply with NGBS, ASHRAE 62.2, LEED, ENERGY STAR[®] IAP, EarthCraft, and California Title-24.



ECM Motor Technology:

When fan senses static pressure, its speed is automatically increased to ensure that the desired CFM is not compromised, which allows the fan to perform as rated.

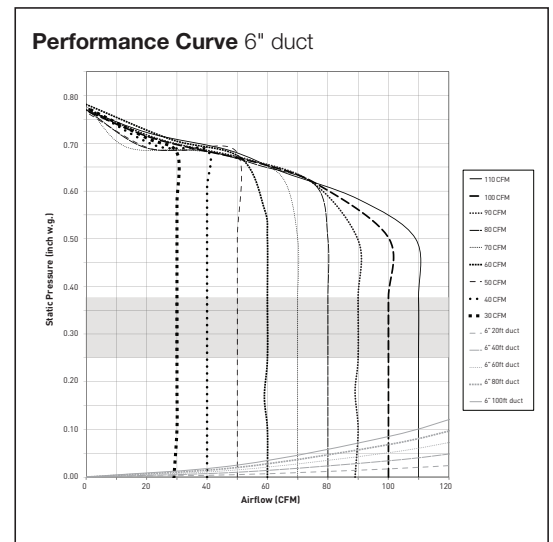
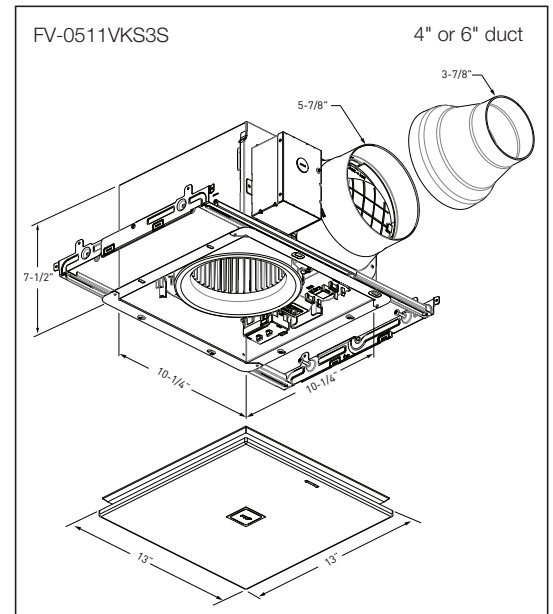

Industry research indicates static pressure in typical installations ranges from 0.20" to 0.375"

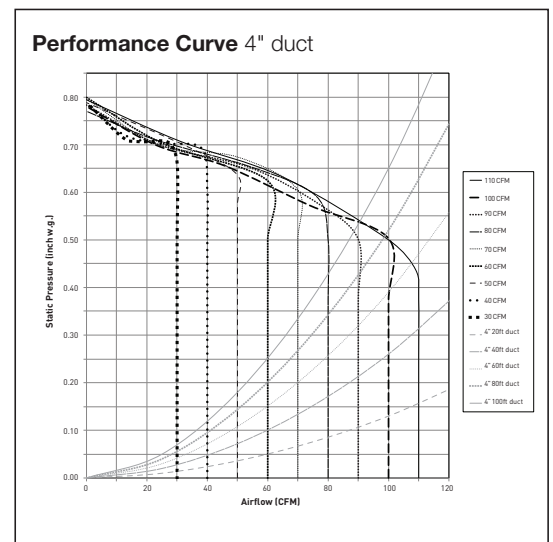

Industry research indicates static pressure in typical installations ranges from 0.20" to 0.375"

Plug 'N Play® Modules

Plug 'N Play® modules provide up to **two** additional features (multi-speed is already built-in to FV-0511VKS2). Select from Motion Sensor and Condensation Sensor.



FV-VS15VK1: Multi-Speed with Time Delay

Allows you to select the proper CFM settings to satisfy ASHRAE 62.2 continuous ventilation requirements. The fan runs continuously at a pre-set lower level (0, 30-100 CFM, in 10 CFM increments), then elevates to a maximum level of operation (50-80-110 CFM) when the wall switch is turned on, or when the motion sensor or Condensation Sensor module is activated. A High/Low delay timer returns the fan to the pre-set CFM level after a period of time set by the user.



FV-MSVK1: Motion Sensor

Automatically activates when someone enters the room. Once the settings have been applied, the fan becomes truly automatic. This module also activates a 20 minute delay off timer for the fan.



FV-CSVK1: Condensation Sensor

Helps control bathroom condensation to prevent mold and mildew. Sensor technology detects relative humidity and temperature to anticipate dew point, automatically turning the fan on to control humidity. Built-in Relative Humidity (RH) sensitivity adjustment enables fine tuning for moist conditions and for satisfying CalGreen requirements. When the condensation sensor is used in conjunction with multi-speed functionality, the fan will kick up to high speed when the condensation sensor detects moisture in the room. This module also activates a 20 minute delay off timer for the fan.



FV-CMVK3: Smart Action® Motion Sensor + Condensation Sensor

Turns the base fan on or boosts to higher speed when condensation or motion are detected. Installer / User can choose the desired operation, thanks to advanced automation. Only one slot is required.



WP100PBA: Smart WiFi® Module

The Wi-Fi control module connects, monitors and controls through Wi-Fi the ventilation fan's features (motion sensor, light, etc.) with the Swidget app.

WhisperGreen [®] Select: FV-0511VKS3S																																				
Duct Diameter (inches)	6"																																			
Static Pressure in inches w.g.	0.1	0.25	0.375	0.5	0.1	0.25	0.375	0.5	0.1	0.25	0.375	0.5	0.1	0.25	0.375	0.5	0.1	0.25	0.375	0.5	0.1	0.25	0.375	0.5	0.1	0.25	0.375	0.5	0.1	0.25	0.375	0.5	0.1	0.25	0.375	0.5
Air Volume (CFM)	110	110	110	109	100	100	100	100	90	90	90	90	80	80	80	80	70	70	70	70	60	60	60	60	50	50	50	50	40	40	40	40	30	30	30	30
Noise (sones)	<0.3	<0.3	---	---	<0.3	<0.3	---	---	<0.3	<0.3	---	---	<0.3	<0.3	---	---	<0.3	<0.3	---	---	<0.3	<0.3	---	---	<0.3	<0.3	---	---	<0.3	<0.3	---	---	<0.3	<0.3	---	---
Power Consumption (watts)	7.4	12.9	18.1	23.8	6.2	11.2	16.6	21.7	5.4	10.6	15.0	19.8	4.7	9.5	13.2	18.1	4.3	8.6	12.4	16.7	3.9	7.7	11.0	15.0	3.4	7.2	10.3	13.4	3.1	6.2	9.1	12.4	2.9	5.6	8.2	11.6
Energy Efficiency (CFM/Watt)	15.2	8.6	6.2	4.6	16.4	9.1	6.3	4.7	17.3	8.8	6.2	4.7	17.3	8.6	6.1	4.5	16.8	8.4	5.8	4.3	16.1	8.1	5.7	4.2	15.2	7.2	5.0	3.9	13.5	6.8	4.7	3.5	11.2	5.9	4.1	3.3
Speed (RPM)	641	932	1120	1282	629	930	1129	1299	620	936	1127	1294	601	928	1111	1294	592	920	1122	1298	590	917	1118	1304	577	930	1130	1303	577	926	1147	1317	585	934	1130	1300
Amps (Current)	0.12	0.21	0.28	0.37	0.11	0.19	0.27	0.34	0.10	0.18	0.25	0.32	0.09	0.16	0.22	0.29	0.08	0.15	0.21	0.27	0.07	0.13	0.19	0.24	0.07	0.12	0.17	0.22	0.06	0.11	0.15	0.20	0.06	0.10	0.14	0.19
MAX. Amps (Current)	0.37																																			
ENERGY STAR Qualified	Yes																																			

WhisperGreen [®] Select: FV-0511VKS3S																																				
Duct Diameter (inches)	4"																																			
Static Pressure in inches w.g.	0.1	0.25	0.375	0.5	0.1	0.25	0.375	0.5	0.1	0.25	0.375	0.5	0.1	0.25	0.375	0.5	0.1	0.25	0.375	0.5	0.1	0.25	0.375	0.5	0.1	0.25	0.375	0.5	0.1	0.25	0.375	0.5	0.1	0.25	0.375	0.5
Air Volume (CFM)	110	110	110	100	100	100	100	90	90	90	90	80	80	80	80	70	70	70	70	60	60	60	60	50	50	50	50	40	40	40	40	30	30	30	30	
Noise (sones)	<0.3	0.6	---	---	<0.3	0.6	---	---	<0.3	0.5	---	---	<0.3	0.5	---	---	<0.3	0.5	---	---	<0.3	0.4	---	---	<0.3	0.4	---	---	<0.3	0.3	---	---	<0.3	0.3	---	---
Power Consumption (watts)	10.7	16.5	22.1	24.8	8.3	14.2	18.8	23.9	7.1	12.4	17.1	21.7	6.2	11.1	15.1	19.6	5.4	9.8	13.8	17.5	4.7	8.5	11.5	15.8	4.0	7.8	10.9	13.9	3.3	6.3	9.1	12.4	3.0	5.8	8.5	11.6
Energy Efficiency (CFM/Watt)	10.5	6.8	5.1	4.1	12.2	7.2	5.4	4.2	12.8	7.5	5.4	4.2	13.0	7.4	5.3	4.1	13.1	7.5	5.4	4.1	13.4	7.4	5.5	4.1	13.6	7.0	5.0	4.1	12.4	6.7	4.7	3.5	10.6	5.9	4.2	3.4
Speed (RPM)	829	1077	1241	1365	783	1047	1212	1367	751	1022	1203	1352	726	1005	1192	1350	708	996	1184	1344	677	970	1155	1329	645	974	1172	1322	617	942	1149	1322	612	949	1147	1307
Amps (Current)	0.18	0.26	0.34	0.38	0.15	0.23	0.30	0.37	0.12	0.21	0.28	0.34	0.11	0.19	0.25	0.31	0.10	0.17	0.23	0.29	0.09	0.15	0.20	0.26	0.08	0.14	0.19	0.24	0.07	0.11	0.16	0.21	0.06	0.11	0.15	0.20
MAX. Amps (Current)	0.38																																			
ENERGY STAR Qualified	Yes																																			

Model	Quantity	Comments	Project:
			Location:
			Architect:
			Engineer:
			Contractor:
			Submitted by:
			Date:

For complete Installation Instructions visit na.panasonic.com/us/iaq

Panasonic
IAQ Division
 Two Riverfront Plaza
 Newark, NJ 07102

na.panasonic.com/us/iaq



Design and specifications subject to change without notice.