

THIS COPY IS PROVIDED ON A RESTRICTED BASIS AND IS NOT TO BE USED IN ANY WAY DETRIMENTAL TO THE INTERESTS OF PANDUIT CORP.

PANDUIT PART #	STUD SIZE		DIMENSIONS in. [mm]				
	ENGLISH	METRIC	L ± .03 [0,76]	W ± .01 [0,25]	C ± .02 [0,51]	M ± .03 [0,76]	H ± .01 [0,25]
PV18-4R	#4	--	.84 [21,3]	.25 [6,4]	.22 [5,6]	.69 [17,5]	.12 [3,1]
PMV1-3RB	--	M3	.82 [20,83]	.23 [5,84]	.22 [5,59]	.70 [17,78]	.13 [3,30]
PV18-6R	#6	M3,5	.86 [21,8]	.25 [6,4]	.22 [5,6]	.70 [17,8]	.15 [3,8]
PV18-8R	#8	M4	.91 [23,1]	.31 [7,9]	.26 [6,6]	.78 [19,8]	.17 [4,3]
PV18-10R	#10	--	.94 [23,9]	.31 [7,9]	.27 [6,9]	.78 [19,8]	.20 [5,1]
PMV1-5RB	--	M5	.91 [23,11]	.35 [8,89]	.29 [7,37]	.75 [19,05]	.21 [5,33]
PV18-14R	1/4"	M6	1.11 [28,2]	.46 [11,7]	.37 [9,4]	.88 [22,4]	.27 [6,9]
PV18-56R	5/16"	M8	1.11 [28,2]	.46 [11,7]	.39 [9,9]	.88 [22,4]	.34 [8,6]
PV18-38R	3/8"	--	1.19 [30,2]	.53 [13,5]	.42 [10,7]	.96 [24,4]	.40 [10,2]
PV18-12R	1/2"	M12	1.42 [36,1]	.72 [18,3]	.53 [13,5]	1.06 [26,9]	.52 [13,2]

UL AND CSA APPROVED TOOLS
 CT-100A - #22-18 AWG
 CT-600-A (CT-500CH) - #22-18 AWG
 CT-600-A (CT-550CH) - #22-18 AWG
 CT-1550 - #22 -16 AWG
 CT-1551 - #22 -16 AWG
 CT-2500 (CT-2550CH) - #22 -18 AWG

PANDUIT APPROVED TOOLS:
 CT-160
 CT-260
 C-400

METRIC EQUIVALENT
 #22 = 0,5mm
 #20 = 0,75mm
 #18 = 1,0mm
 #16 = 1,5mm

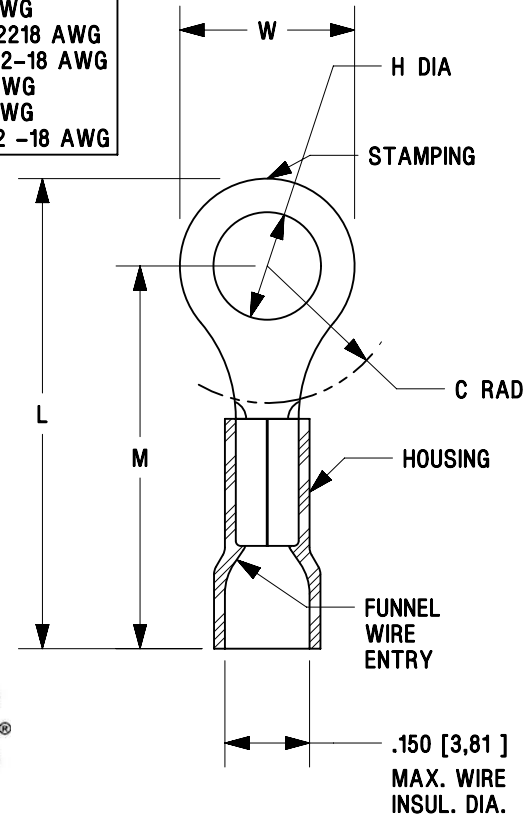

LISTED
587H
E52164

CERTIFIED
LR31212

NOTES:

- UL 486A/B LISTED & CSA C22.2 NO 65-03 CERTIFIED FOR:
 - SOLID OR STRANDED COPPER WIRE
 - 221°F [105°C] MAX. OPERATING TEMPERATURE
 - 600V. MAX. BLDG WIRE (1000 V. MAX. IN SIGNS, FIXTURES & LUMINAIRES)
 - SOME TOOLS HAVE EXPANDED SIZES. SEE TOOL TABLES FOR AWG WIRE SIZES SUPPORTED BY EACH TOOL.
- SEE www.panduit.com FOR PACKAGE QUANTITIES INDICATED BY PART NUMBER SUFFIX
- MATERIAL:**
 - STAMPING: .032" [0,8] THK COPPER, TIN PLATED
 - HOUSING: VINYL, RED
- DIMENSIONS IN BRACKETS ARE METRIC EQUIVALENT
- WIRE STRIP LENGTH: 5/16 ^{+1/32}/₋₃ [7,9 ^{+0,8}/₋₃]

13A	9-5-24	JHNU	JHNU	MRWA	D. REVISED DIMENSION L TOLERANCE: .03 [0,76] WAS .03 [0,51] C. REVISED DIMENSION C TOLERANCE: .02 [0,51] WAS .02 [0,38] B. REVISED DIMENSION M TOLERANCE: .03 [0,76] WAS .03 [0,51] A. REVISED DRAWING FORMAT	005862/00
-----	--------	------	------	------	--	-----------

PART NUMBER		SEE TABLE	
TITLE			
#22-18 BARREL FUNNELED VINYL INSULATED RING TONGUE, .150 [3,81] MAX WIRE INSUL DIA.			
CUSTOMER DRAWING			
ITEM REVISION NAME		N41268BA/13	
DATASET FILE NAME		N41268BA_DC/13A	
MATERIAL		SEE NOTES	
DRAWN BY		DAW	
DATE		7-09	
CHK		CJH	
SCALE		NONE	
DRAWING NUMBER		N41268BA-DC	
SHEET 1 OF 1		A	

A-SIZE CUSTOMER