

LIGHTSAVER® DIMMING PHOTOSENSOR

LS-301



All setup performed remotely with handheld

Controls standard 0-10 VDC electronic dimming ballasts or compatible LED drivers

Single zone control

Automatic dimming based on ambient light levels

Optional occupant adjustment via handheld remote

Closed loop daylighting control

DESCRIPTION

The LightSaver LS-301 is a closed loop, ceiling mount, low voltage indoor photosensor that works with standard, 0–10 VDC electronic dimming ballasts or compatible LED drivers to dim lighting as daylight increases

OPERATION

The LS-301 mounts on a ceiling and utilizes a spectral filtering system to measure daylight and electric light levels. A closed loop daylighting system, the LS-301 measures the total light level from daylight and electric light in the controlled area to adjust electric lighting levels. As the daylight contribution increases, the lights dim down. The photosensor utilizes sliding setpoint control, which responds to the different spatial distribution qualities of electric light and daylight. The LS-301 calculates the required light level for current daylight contribution based on two setpoints. One represents the target level when no daylight is present (night setpoint) and the other when significant daylight is present (day setpoint).

ADJUSTMENT VIA HANDHELD REMOTE CONTROL

All LS-301 adjustments are made with one of two handheld remotes. The LSR-301-S provides five buttons for initial set-up, which is easily completed by first raising or lowering electric light levels to desired levels, then programming this target level into the photosensor. The LSR-301-P provides three buttons for occupants to adjust light levels. With this optional tool, users can increase target light levels by up to 25% or reduce them to the lamp/ballast minimum level. Pressing the “Auto” button returns the control to programmed levels.

APPLICATIONS

The LS-301 is designed to blend into its surroundings when installed in any environment. It provides one zone of daylighting control in a private office or classroom. In these applications, the LS-301 can be combined with an occupancy sensor. Often, it is possible for the LS-301 to share a single power pack with occupancy sensor(s).

FEATURES

- Provides precise control of lighting to maintain desired light level
- Extremely linear photocell response with greater than 1% accuracy
- Designed to measure light as the human eye perceives it, eliminating “overreporting” illumination levels provided by daylight
- California Title 24-2013 compliant
- Separate handheld remote controls for setup and occupant adjustment to prevent tampering
- Boosts energy savings by reducing maximum lamp output, often resulting in a 20% reduction or more compared with lights at full output
- Achieves lumen maintenance by holding target light level as lamp output decreases over time

PROJECT

LOCATION/
TYPE

SPECIFICATIONS

- Full range dimming: .2 VDC (minimum) to 10 VDC (100% lighting) output voltage
- Current consumption: 30 mA @ 24 VDC
- In typical applications, setpoints are adjustable from 20–60 footcandles (210–640 lux)
- Controls up to 50 standard dimming ballasts in one zone
- Sensor leads: gray and violet to dimming ballast, red and black to 24 VDC
- Dimensions: 2.35" diameter. x 0.875" depth (60mm x 22mm), threaded piece extends 1.25" (31.8mm) from back, fits .5" knockout
- UL and cUL listed
- Five year warranty

PRODUCT CONTROLS

Remote Controls

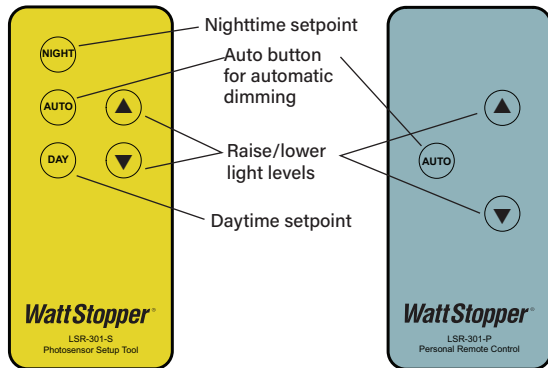

Remote handheld (left) enables easy set-up while optional occupant remote provides adjustability for individual lighting preferences.

Spectral Response Curve

The spectral response of the LS-301 photocell closely matches the sensitivity of the human eye.

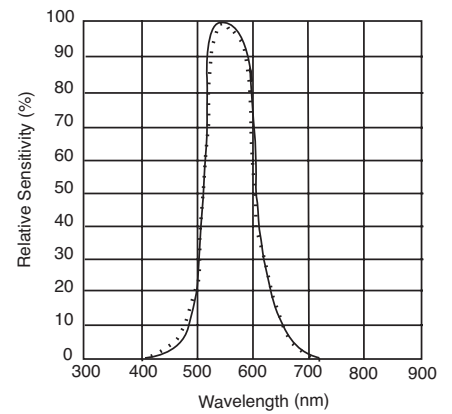

WIRING & INSTALLATION

Wiring

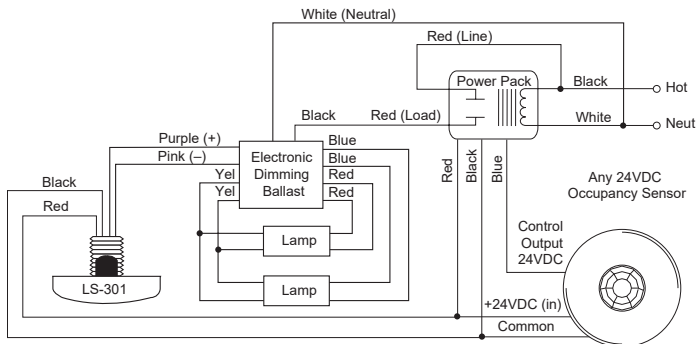

NOTE: Per UL, the 0-10V negative dimming wire color has been changed from gray to pink.

Mounting and Installation

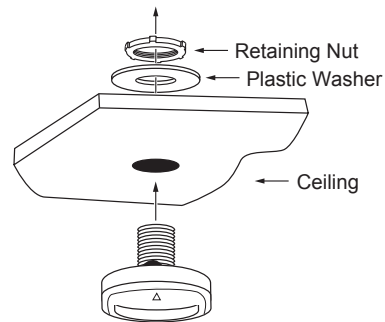

COVERAGE

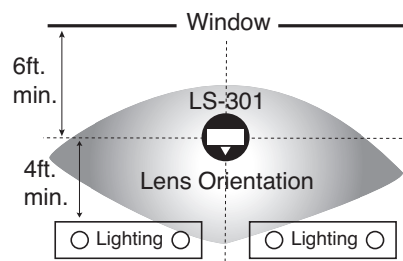

Placement Guidelines

Mount photocell between 6 and 12 feet (1.8m - 3.7m) from window.

Do not mount directly above direct/indirect pendant fixtures. Mount at least 4 feet (1.2m) from pendant fixtures.

ORDERING INFORMATION

Catalog #		Description	Input Voltage
<input type="checkbox"/>	LS-301	Dimming Photosensor	24VDC
<input type="checkbox"/>	LSR-301-S	Setup Remote Control	
<input type="checkbox"/>	LSR-301-P	Occupant Remote Control	

LS-301 works with Wattstopper power packs.