

- Parts Included:**
- (1) - Extra Door Spacer
 - (6) - Keys
 - (1) - Roll of Tak-Ty
 - (12) - #12-24 Screws
 - (1) - Removable Top Vent Cover Panel

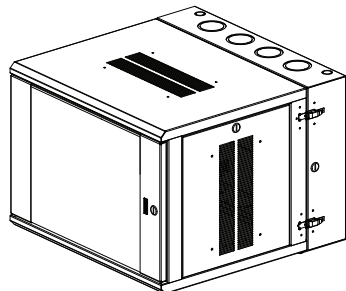

PZWMC9W

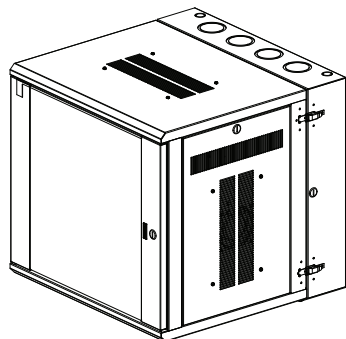

PZWMC12*

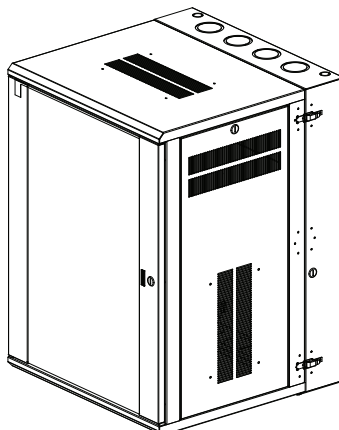

PZWMC18*

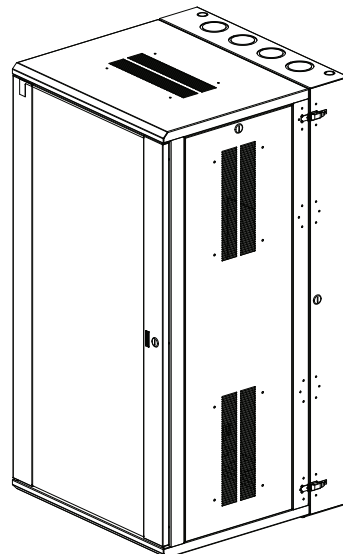

PZWMC26*

Location Footprint

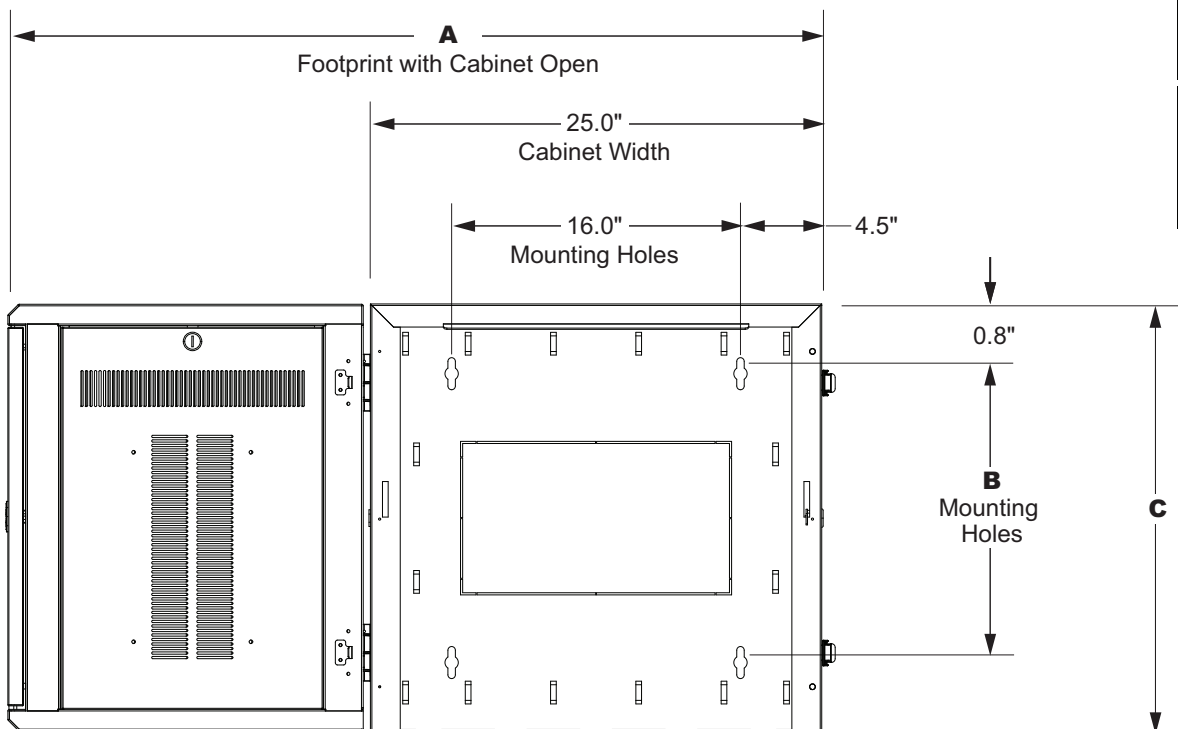

CABINET DEPTH	DIM "A"
25.0"	45.1"
30.0"	50.1"

RU	DIM "B"	DIM "C"
9	15.5"	18.5"
12	20.7"	23.8"
18	31.2"	34.3"
26	45.2"	48.3"

PANZONE Wall Mount Cabinets can be installed in a hinged right or hinged left application. For your installation, determine which side of the cabinet will hinge. The cabinet is shown hinged left. Mounting surface must have **sufficient strength to support the cabinet with payload in both vertical and horizontal loads**. The mounting surface must also be flat and extend beyond the overall cabinet footprint to avoid over rotation, refer to dimension "A" on page 1 for required wall mounting dimension. Do not install the enclosure with the back panel extending beyond the edge of the wall.

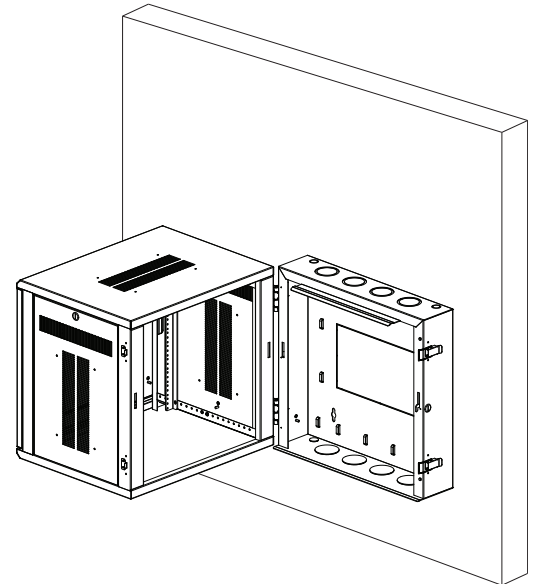
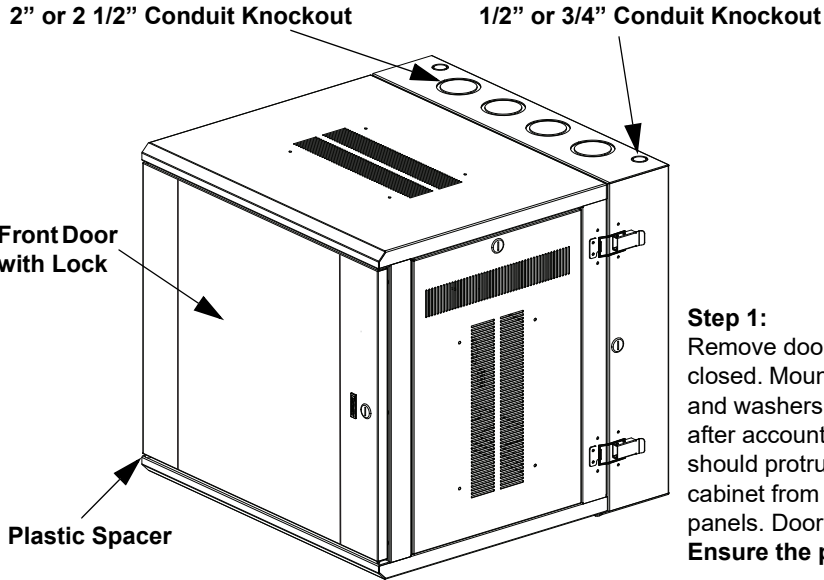

Step 1:

Remove door and side panels for ease of handling. Ensure rear latches are closed. Mount the cabinet to studs in four locations with four (4) 3/8" lag screws and washers (not provided). Screws must penetrate wood studs at least 2 7/8" after accounting for wall board and backerboard material thickness. Hardware should protrude 3/8" from wall. Once the cabinet is in place, carefully swing cabinet from wall and tighten the hardware securely. Re-install door and side panels. Door swing direction can be changed by rotating the door 180°. **Ensure the plastic spacer is placed at the bottom of the door hinge.**

Step 2:

To reverse rear hinge direction.

Open cabinet, and remove the latch from the rear lock. Remove the rear lock and the lock hole grommet on the opposite side. Close the cabinet and remove decorative covers on hinges. Remove the thread forming screws, lockwashers & flange nuts from the hinges (M5), and latches (M4), and re-install the components on the opposite side of the cabinet. Torque screws to 42.5 in-lb ± 3.5 in-lb. Open the cabinet and re-install the lock and grommet on the opposite sides. Re-assemble the lock latch, ensuring it locks in the downward rotation (see below).

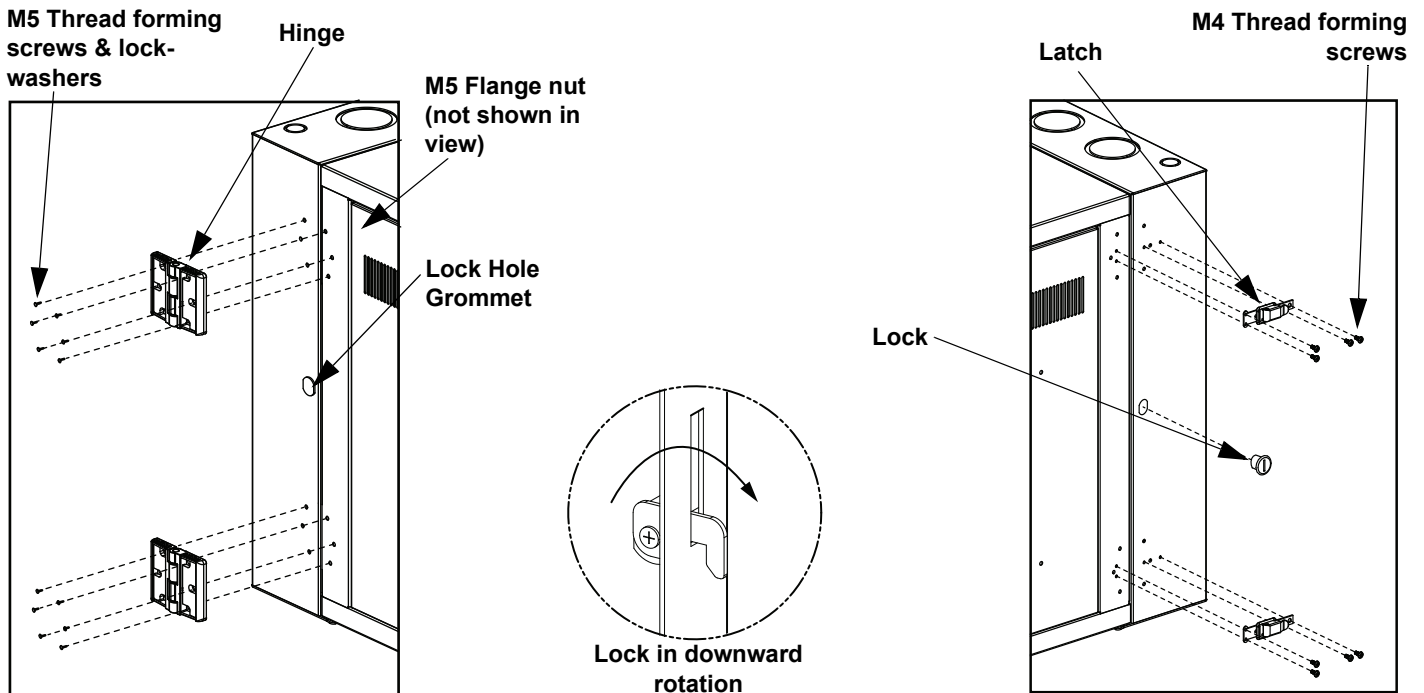

Step 3: To adjust the depth of the mounting rail for specific applications, remove the M6 thread forming screws and lockwashers, move the rail to the desired position and re-install mounting hardware.

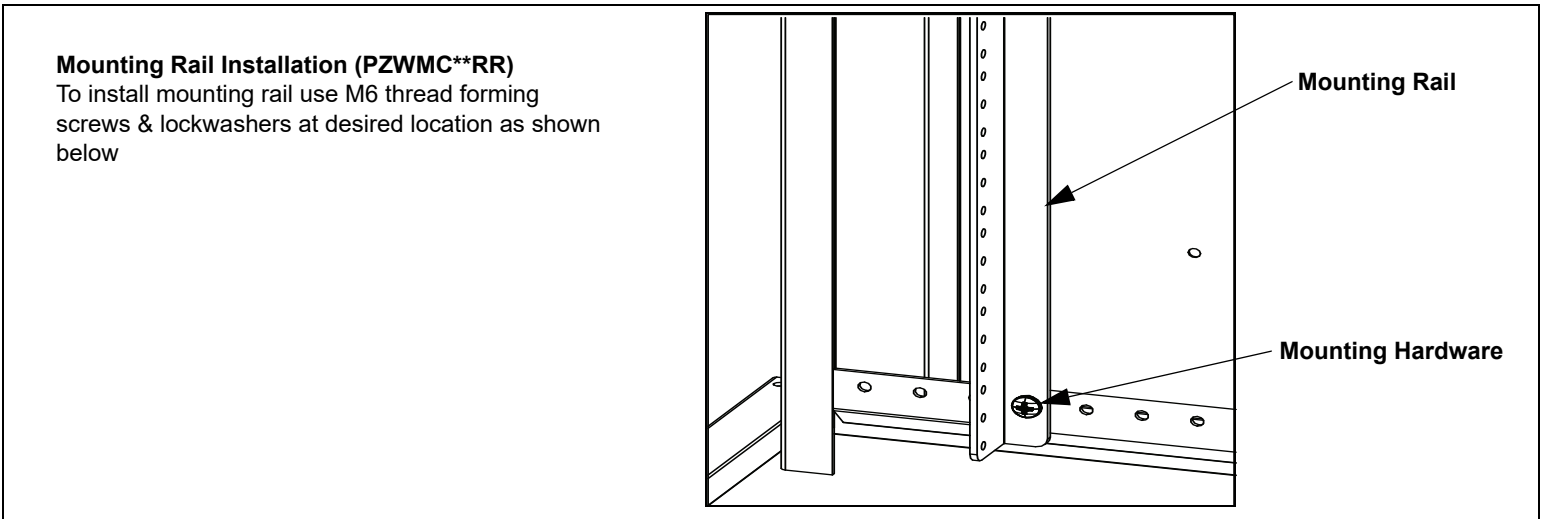
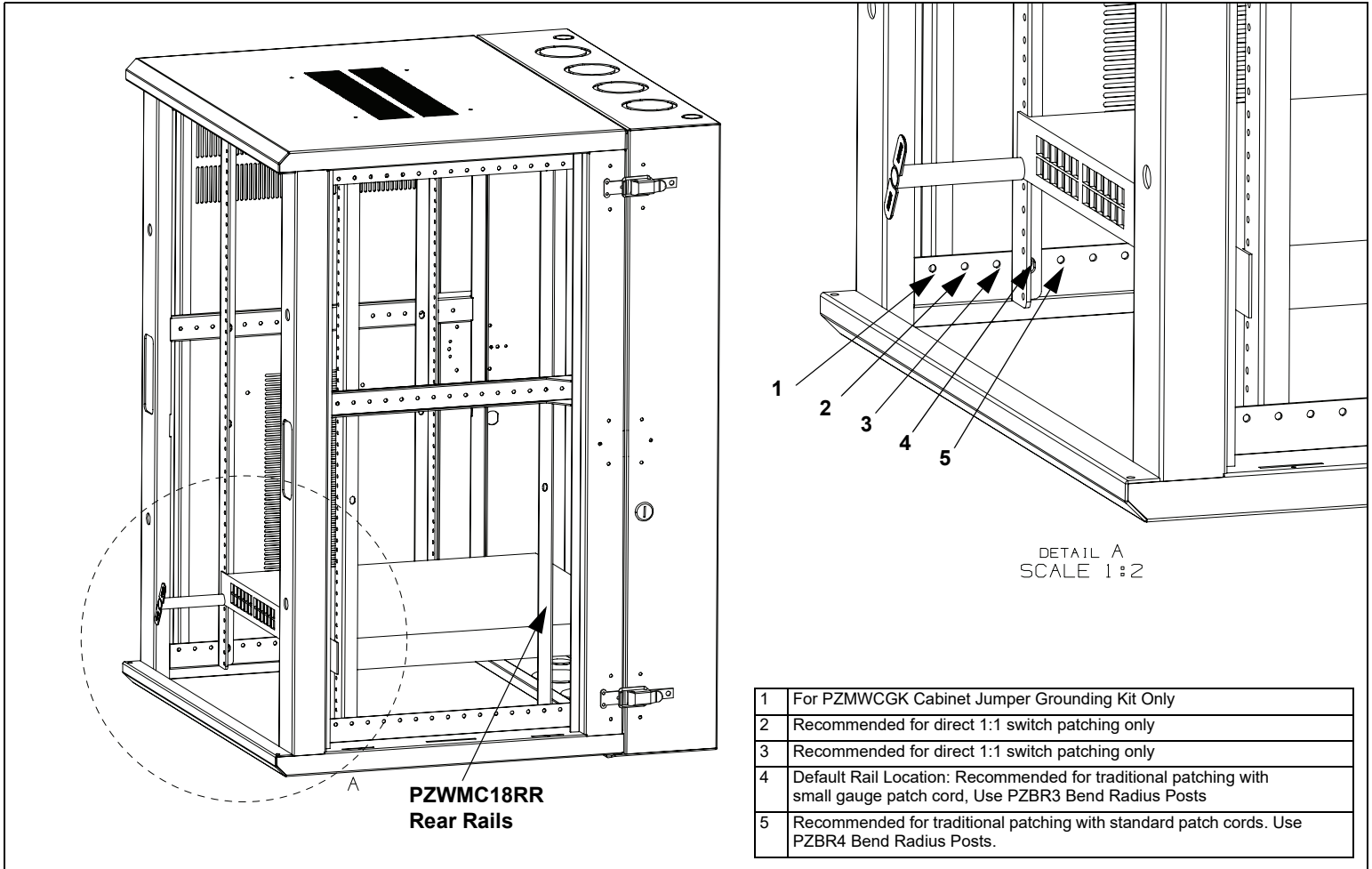

For Technical Support: www.panduit.com

Cable Routing

Cable must be routed with an adequate slack loop to prevent cable damage. Route cable to point 1 secure to tie down with a *TAK-TY*. Next route cable across the bottom of the enclosure to point 2 secure to tie down with a *TAK-TY*. Route to the desired patch panel after securing the cables with a *TAK-TY* at point 3 or 4.

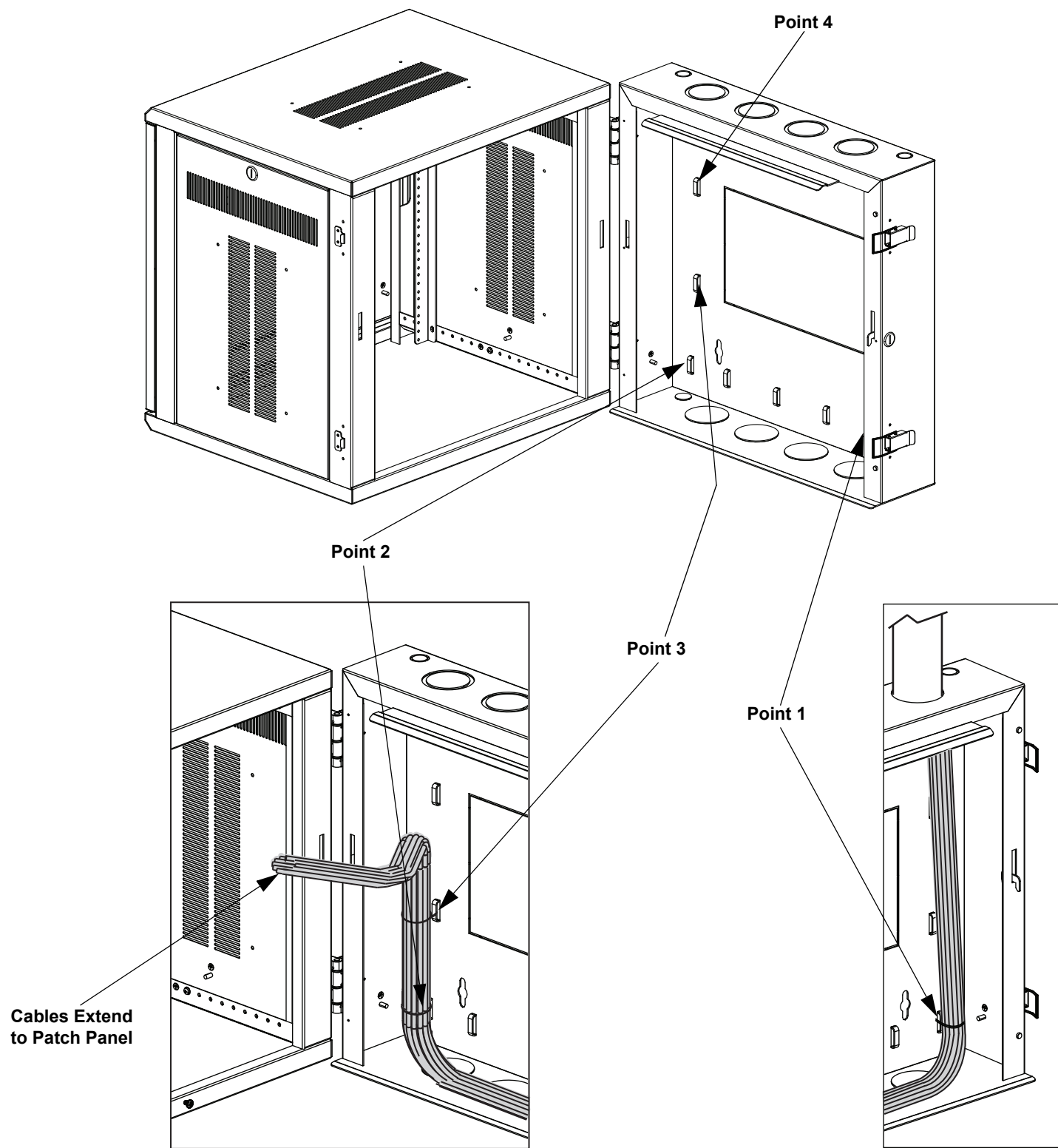

Optional Accessories

PZWMC12W (Shown)
Cabinet with Window Door

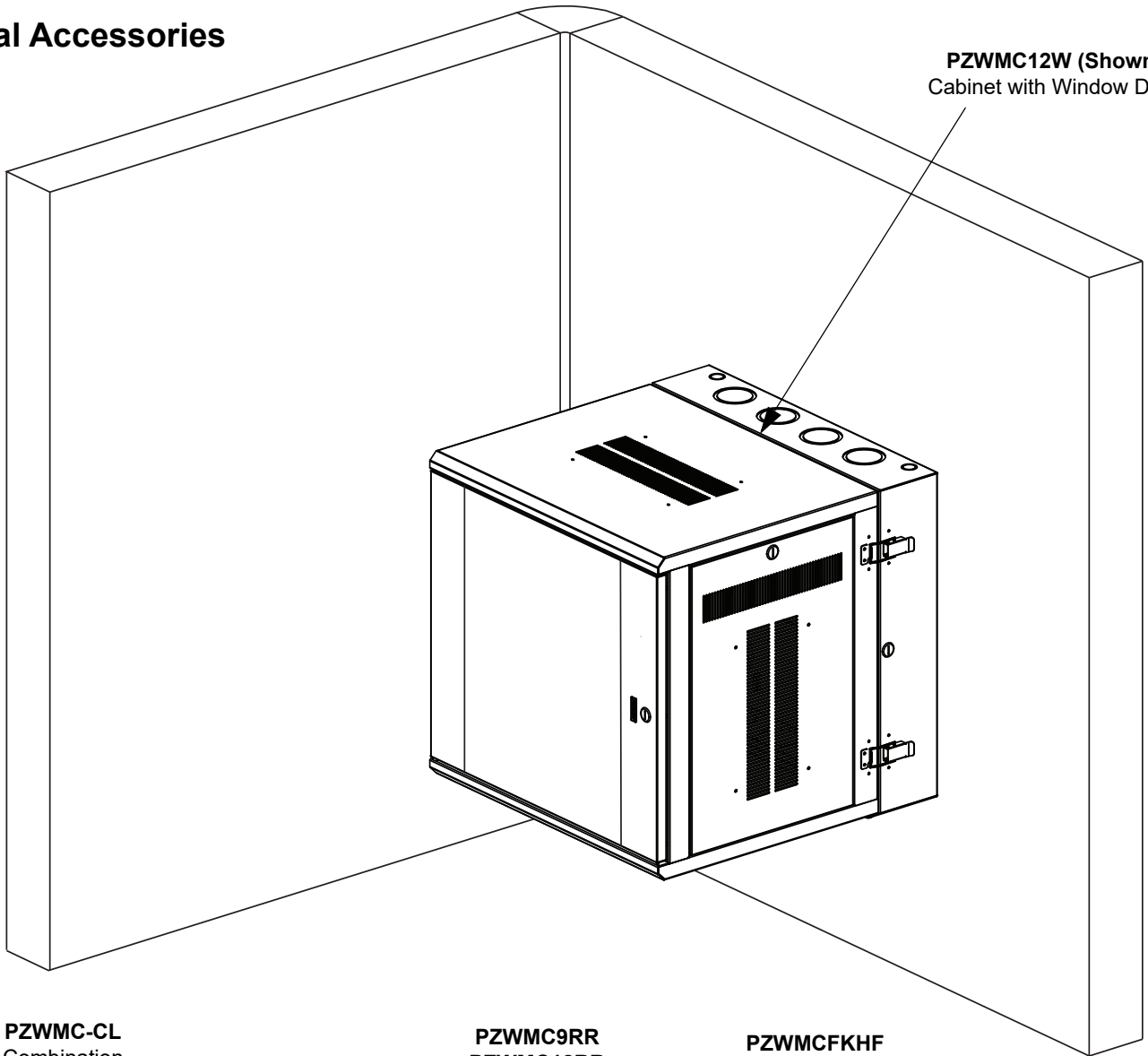

PZWMC-CL
Combination
Lock Kit

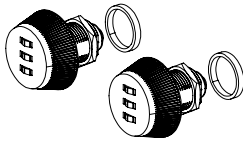

PZWMC9RR
PZWMC12RR
PZWMC18RR
PZWMC26RR
PANZONE Rear Equipment
Rail Kits

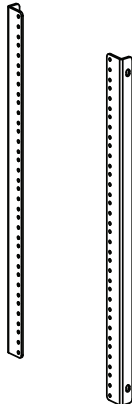

PZWCMFKHF
PZWCMFKHF-E
PANZONE
Fan Kit
High Flow

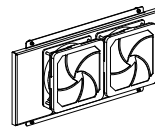

PZCFK
PZCFK-E
PANZONE Fan Kit

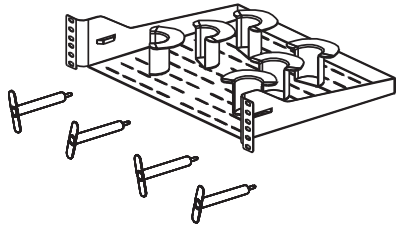
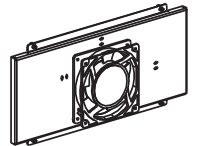

PZCHSM2
PANZONE Horizontal
Slack Manager

PZBR4
PANZONE 4" Bend
Radius Post Kit

PZBR3
PANZONE 3" Bend
Radius Post Kit

PZCFR
PANZONE Fan Media
Replacement Kit

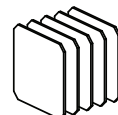

For Technical Support: www.panduit.com

PANZONE Fan Kits (PZCFK, PZCFK-E, PZWMCFKHF, PZWMCFKHF-E)

Fan kits are installed using (4) #10-32 screws and lockwashers provided with kit as shown below. If only one fan kit is used, install the provided blank on the opposite wall using (4) #10-32 screws and lockwashers provided. For European Schuko (240V) plugs, use fan kits with '-E' part numbers

Scenario 1: Switches not exceeding 120 watts of total heat output use fan kit as shown.

Scenario 2: POE (Power over Ethernet) or switches totaling over 120 watts of total heat, use two PZCFK fan kits or one PZWMCFKHF. Mount second fan where blank is shown.

Optional: Remove Top Panel Blank for additional venting. A fan kit can be installed on top vent, but will occupy the top RU space. NOTE: Fan kits draw air into the cabinet.

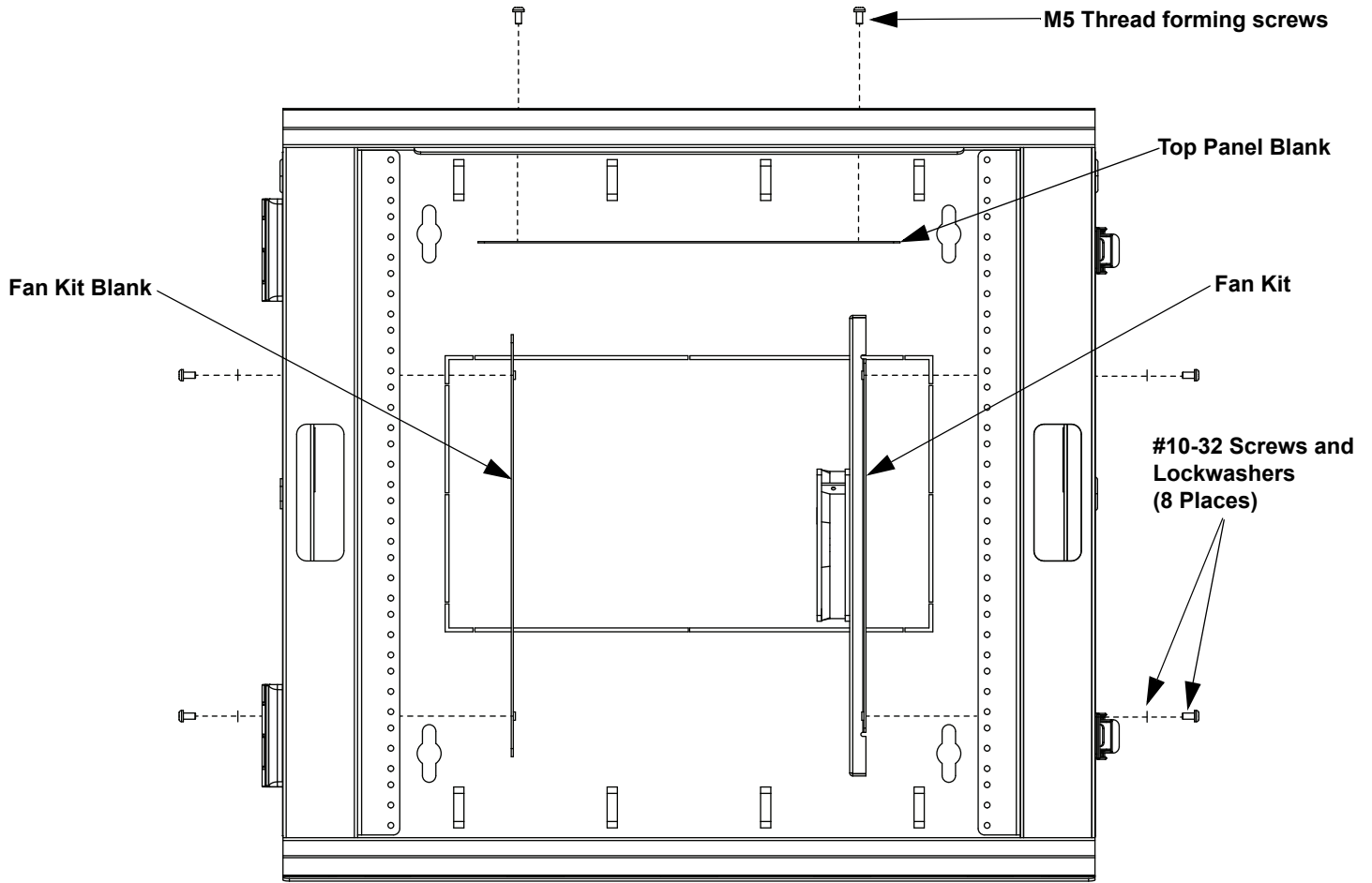

Note: When using switches with side air intake and opposite side exhaust use one fan without fan blank

PANZONE Horizontal Slack Manager (PZCHSM2)

Install tray using (4) #12-24 x 1/2 screws provided at desired RU as shown in figure 3. Refer to recommended layout section for optimal mounting location(s).

Figure 3

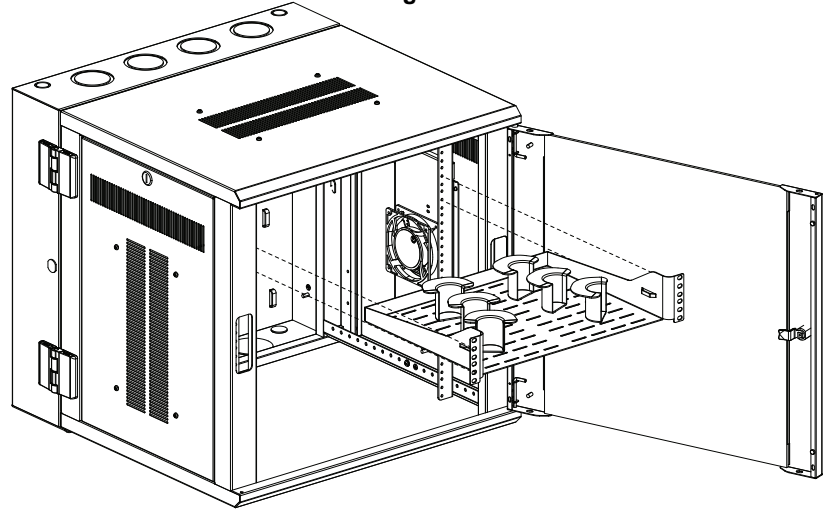
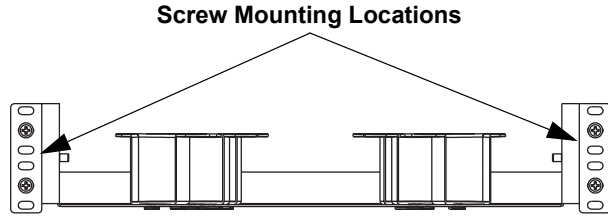

Bend Radius Post Installation

Bend radius posts can be installed at any rack location using (1) #12-24 x 2.5" [(1) #12-24 x 1.5" for PZBR3] screw provided as shown in Figure 1. Post can be customized by removing tabs as show in Figure 2.

Note: Post may be installed over active equipment mounting locations.

Figure 1

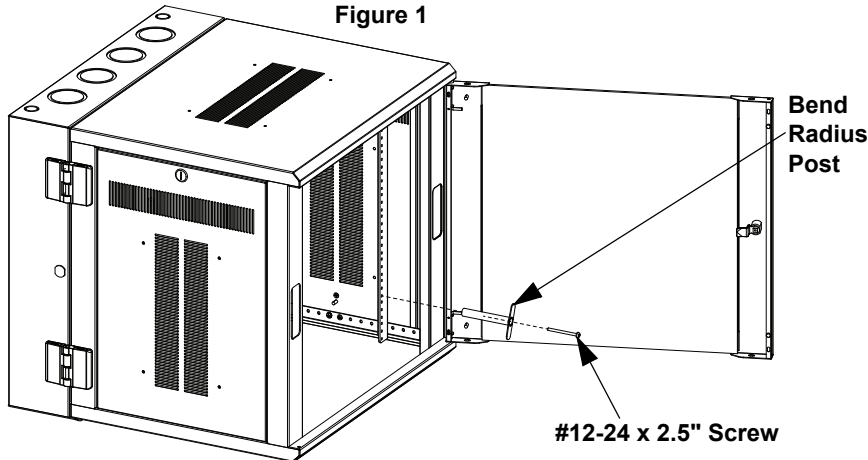
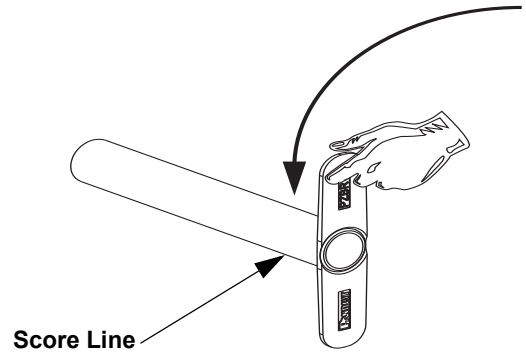

Figure 2



PANZONE Lock Kits (PZWMC-CL)

Kit Contents

- Combination locks (2)
- Spacer rings (2)
- Cylinder nuts (2)
- Retaining screw (2)
- Lock washers (2)
- Flat washers (2)
- Direction setting washers (2)

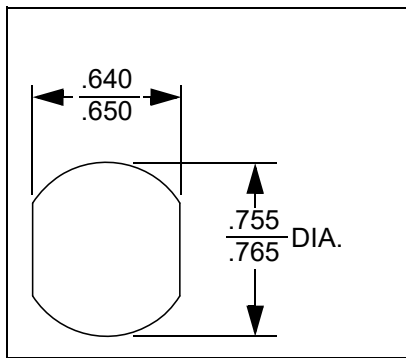
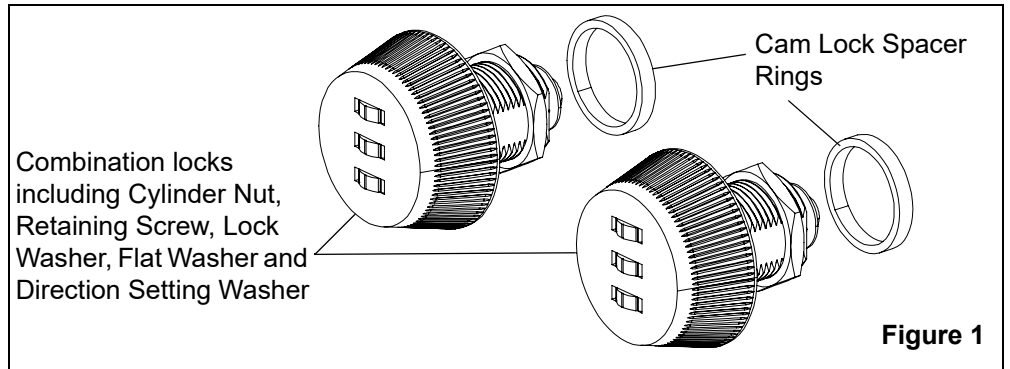

Mounting Cutout

Installation

- Remove the existing locks from the cabinet and save cams for later use. (Figure 2)
- Remove the Cylinder Nut from the Combination Lock and insert the Spacer Ring over the Lock Cylinder. (Figure 3)
- Install the Combination Lock onto the Cabinet and tighten the Cylinder Nut. The Lock Head should be spaced away from the Cabinet Surface. (Figures 3 & 4)
- Remove the Retaining Screw, Lock Washer, Flat Washer, and Direction Setting Washer.
- Pull the Lock Head from the cylinder and rotate until oriented in the desired direction. (Figures 5-7)

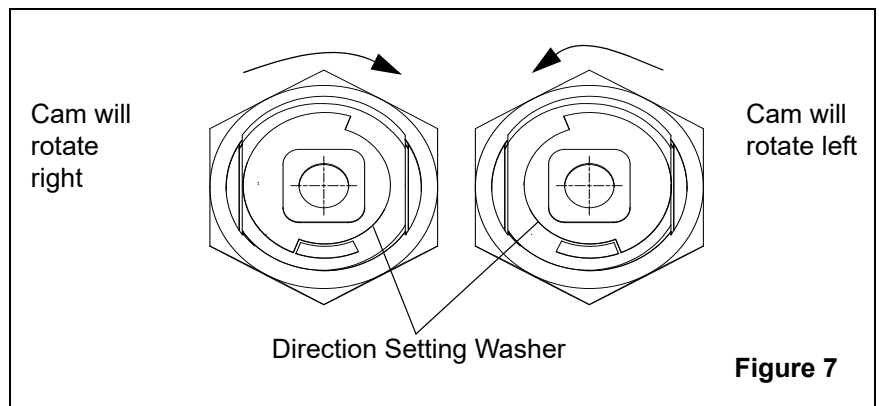
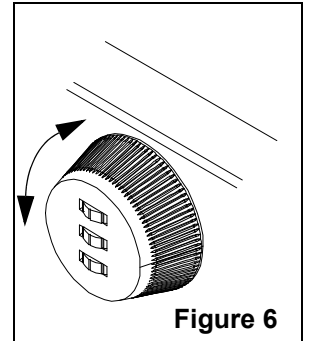
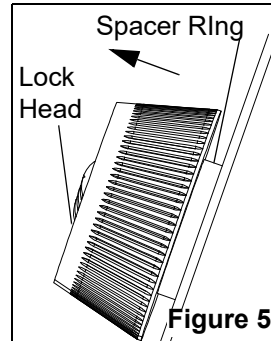
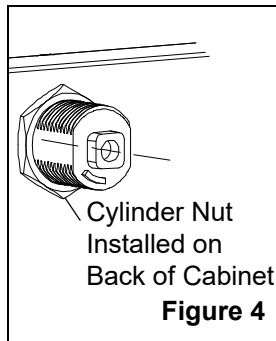
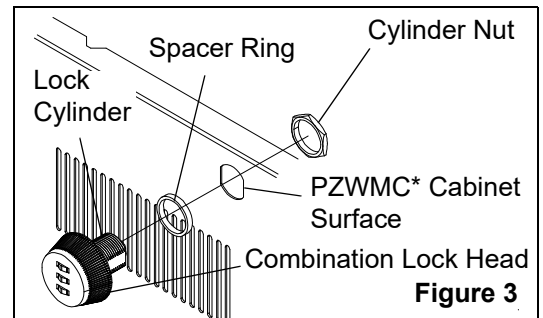
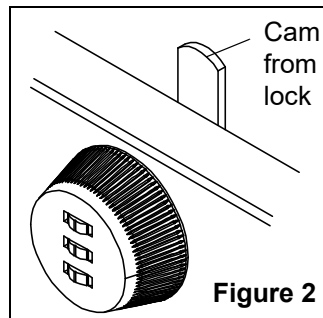

Installation (continued)

- Install the remaining parts in the following order: Direction Setting Washer, Cam (saved from previous lock), Flat Washer, Lock Washer, and Retaining Screw. (Figure 7)
- Set the lock to the factory combination 0-0-0.
- Test lock rotation direction. Adjust cam angle if necessary

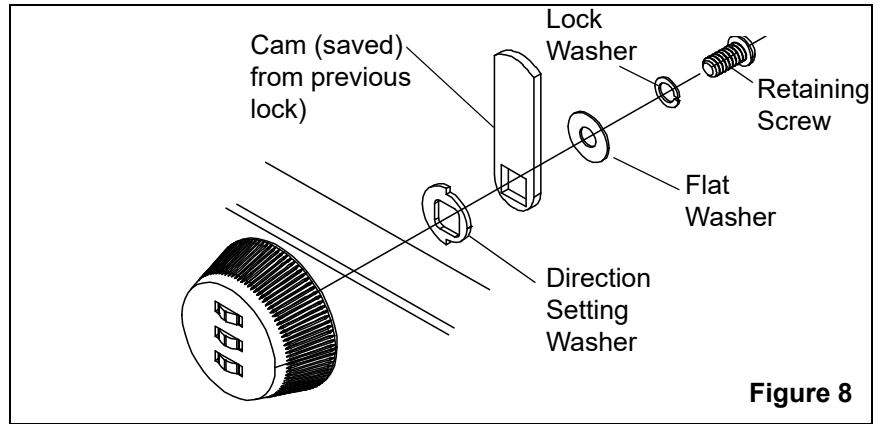

Figure 8

To Change Combination:

- Set the lock to the previous combination or factory combination (0-0-0).
- Push reset button with pin. (Figure 9)
- While reset button is pushed, scroll numbers to the desired combination. (Figure 9)
- Release the reset button to set the combination.

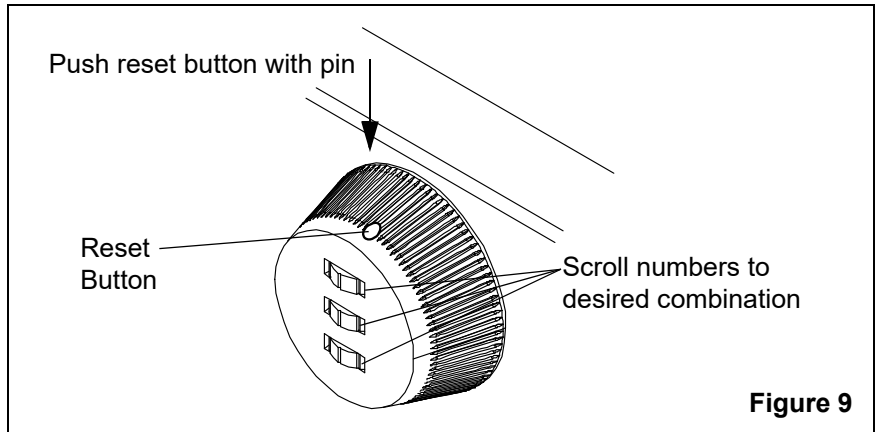

Figure 9

To Hide the Reset Button:

- Set the lock to the desired combination.
- Remove the direction setting washer, cam, flat washer, lock washer, and retaining screw. (Figure 12)
- Pull out the lock head and rotate 180°. (Figures 10-11)
- Reinstall the direction setting washer, cam, flat washer, lock washer, and retaining screw. (Figure 12)

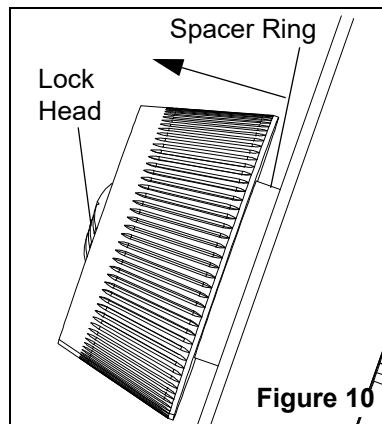

Figure 10

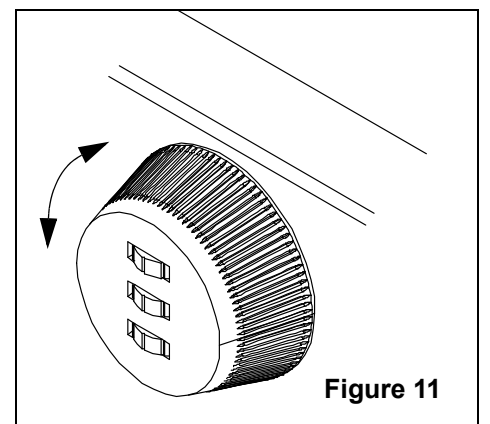

Figure 11

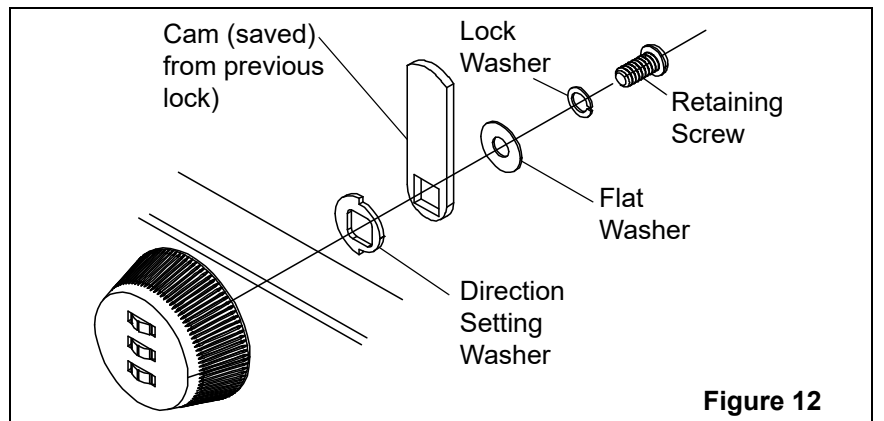
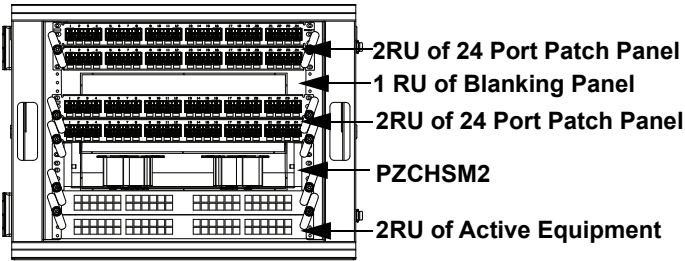
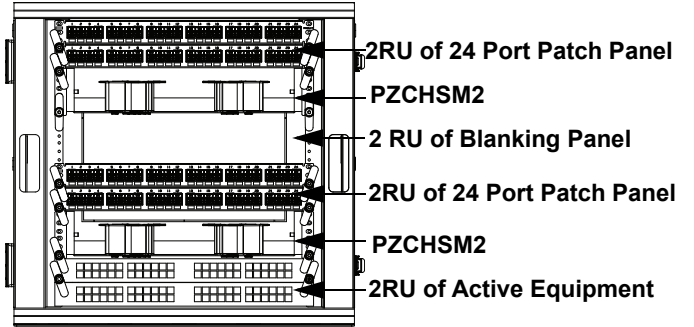

Figure 12

Recommended Layout (9 RU)



Recommended Layout (12 RU)



Recommended Layout (18 RU)

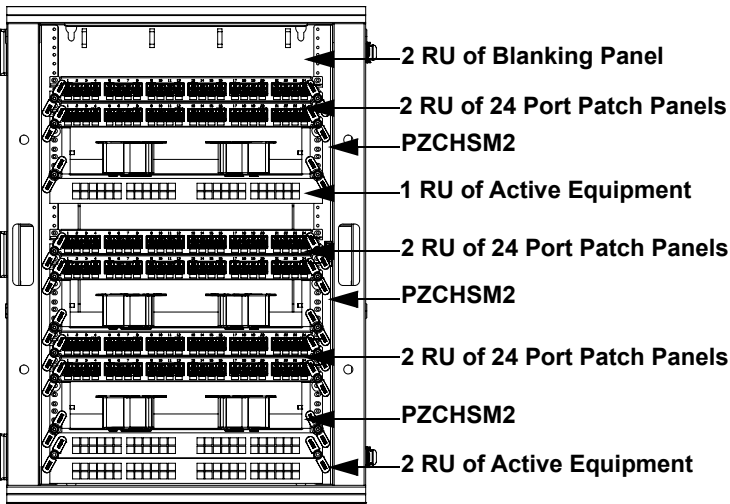

Recommended Layout (26 RU)

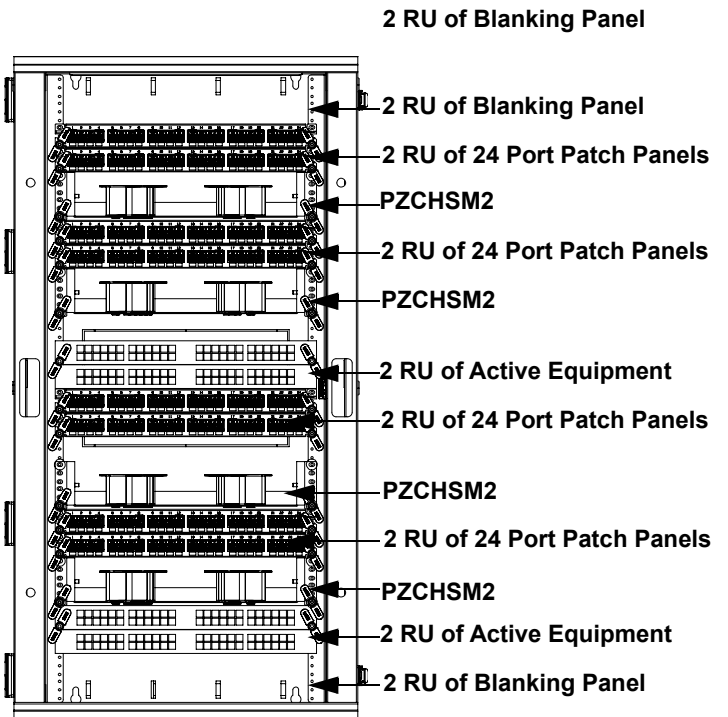

Recommended Cable Routing Guide

Place patch cord slack around furthest spool as feasible to provide best possible cable management

Top View of PZCHSM2

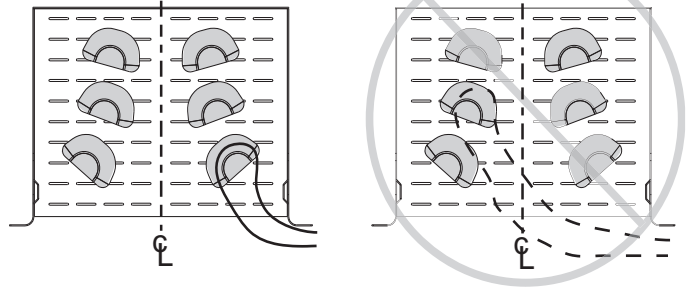

Never cross over center line of horizontal slack manager with cable slack

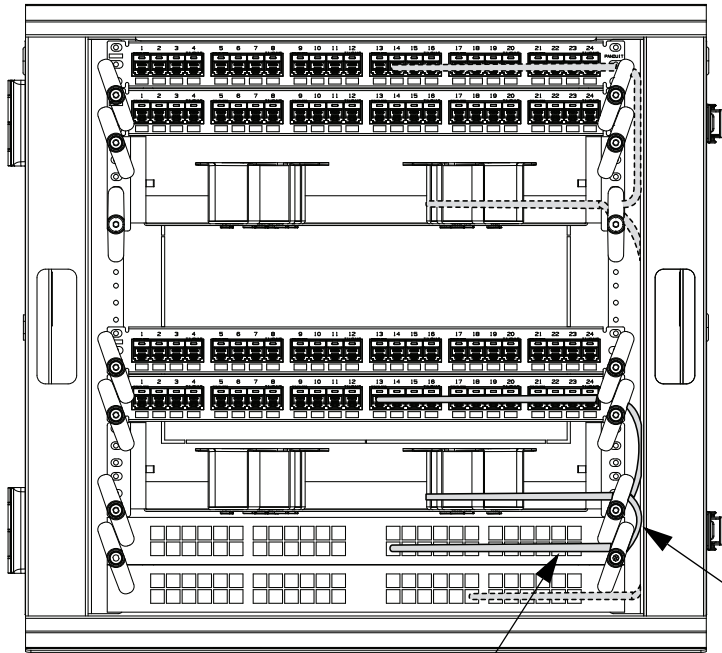

Typical patch cord length is 4 feet minimum
Route patch cords as shown to avoid crossover

Recommended Mounting Locations for Bend Radius Posts

Typical patch cord length is 5 feet minimum
Route patch cords as shown to avoid crossover

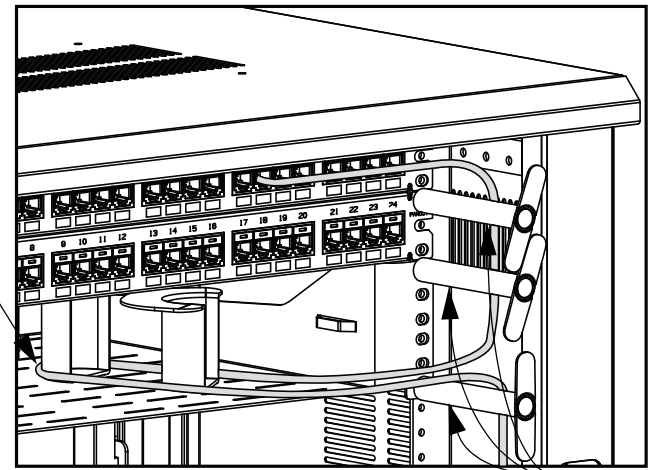
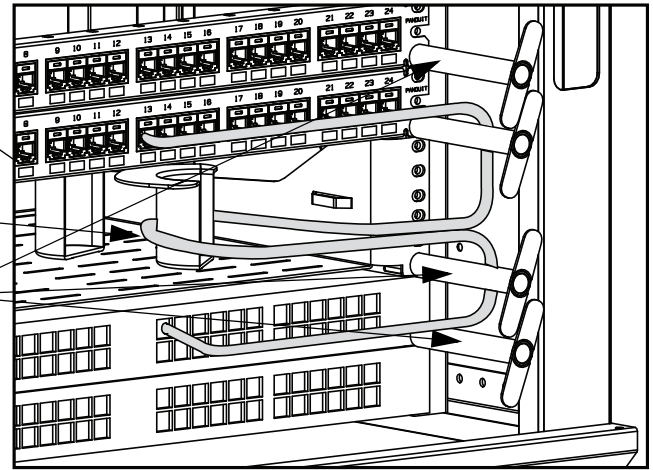

Lower Horizontal Manager

Recommended Mounting Locations for Bend Radius Posts

Route patch cords going to top horizontal slack towards the outside of the cabinet to avoid cross overs with patch cords going to lower slack manager.

Routed to top Horizontal Slack Manager

For instructions in Local Languages and Technical Support:

www.panduit.com



E-mail: techsupport@panduit.com
Phone: 866-405-6654