

# ESY3xxV



## Extension current modules



### Benefits

- **Compact housing.** 1-DIN housing dimension to facilitate installation near the loads to be monitored.
- **Multi-load management.** The EMS system manages up to 10 ESY modules connected to it via the ESY bus network. Each ESY module manages up to three current channels and it is possible to distribute the measurements coming from the three current sensors in one or more loads.
- **Self supply.** The ESY devices are self-powered by the ESY bus, therefore they do not require a separate power supply.
- **Plug and play fast installation.** Once connected to the ESY bus network via Ethernet cables, the device is automatically found by the EMS system.

### Description

Three-phase current measurement accessory for the EMS system, compatible with 333 mV or 5 A current transformers.

The small size allows the module to be installed close to the loads to be monitored and thanks to the two RJ45 ports it is possible to easily connect up to 10 ESY devices in cascade to the EMS.

Each ESY module is self-powered and is automatically found by EMS once it is connected to the ESY bus; the programming is done through the EMS web app.

### Applications

ESY device can be installed in any low-voltage switchboard to monitor the energy consumption and the electrical variables of any load. Compatible with any current transformer with 5 A secondary current, it can be installed in systems with rated current up to 10 kA, even in retrofit applications if used with openable transformers like CTA or CTD S.

## References

 **How to order**

 **ESY3X**

Enter the code option instead of

Code	Options	Description
<b>ESY3X</b>	-	-
	<b>AV5</b>	5 A CT connection
	<b>MV</b>	333 mV CT connection

## Main functions

- Measure active, reactive and apparent energy
- Measure the main electrical variables
- Measure the load run hours
- Transmit data to EMS system through ESY-Bus
- Measure the total harmonic distortion (THD) of currents

## Architecture

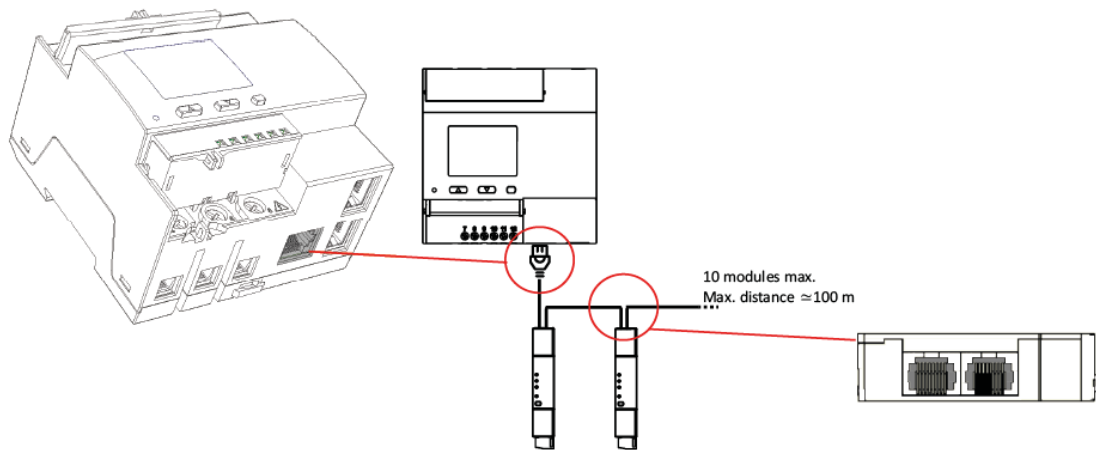

*Important note: Each EMS module is provided with the ESY bus termination (see the picture below).*



*This termination unit must be applied to the last ESY module of the network.*

## Structure

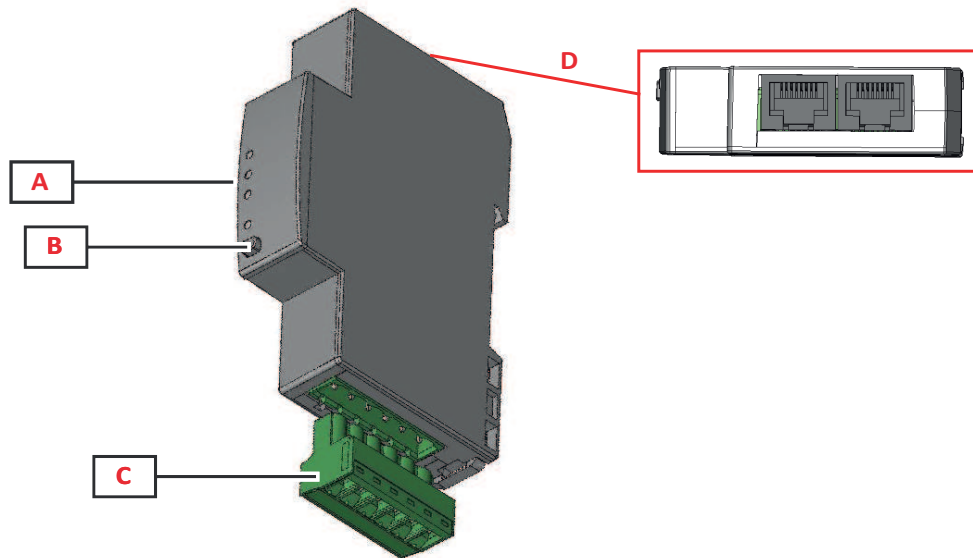

Area	Description
A	LED
B	Identification button
C	Current transformer terminal
D	ESY bus ports

# Features

**General**

<b>Material</b>	Housing: PBT Colour standard CG RAL7035 Transparent cover: polycarbonate
<b>Dimensions</b>	1 DIN module
<b>Weight</b>	110 g
<b>Protection degree</b>	Front: IP40 Terminals: IP20
<b>Mounting</b>	DIN rail
<b>Overvoltage / Measurement category</b>	III
<b>Pollution degree</b>	2
<b>UV resistant</b>	Yes (frontal part)
<b>Shock resistance</b>	According to IEC 60068-2-27 with conditions prescribed in IEC 62052-11
<b>Vibration resistance</b>	According to IEC 60068-2-6 with conditions prescribed in IEC 62052-11
<b>Mechanical strength</b>	IK08 (S) and IK06 (C, U, I, BCM, IO)
<b>Impact resistance</b>	Front: 1J (IEC 61010-1 Ed 3.0)

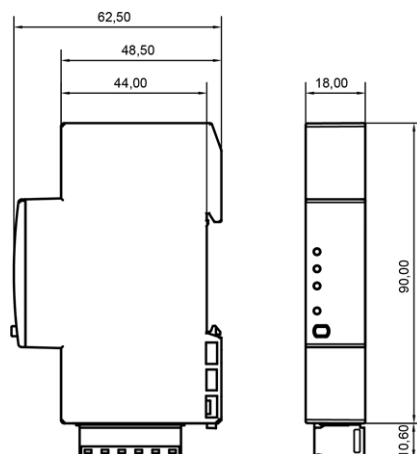

**Connections**

<b>Bus voltage range</b>	15 to 20 V nominal (12 to 24 V with tolerance)
<b>Bus current</b>	Max 500 mA (current limit protection)
<b>Cable type</b>	Min Cat 5e, not crossed
<b>Cable length</b>	Max 100 m
<b>Bus type</b>	Daisy chain (refer to standard Modbus RTU requirements)
<b>Number of slaves</b>	Max 10 units (11 units are allowed for the substitution case)
<b>Termination</b>	The last slave device connected to the bus must be terminalized by provided accessory

**Environmental**

<b>Use</b>	Indoor
<b>Operating temperature</b>	From -25 to +70 °C / from -13 to +158 °F
<b>Specified operating range</b>	From -10 °C to +45 °C / from 14 to +113 °F (class 3K5 mod.)
<b>Storage and transport temperature</b>	From -25 to +75 °C / from -13 to +167 °F (class 3K8H)
<b>Relative humidity</b>	<90% @40°C (class 3K6 according to IEC 62052-11)
<b>Altitude</b>	Max 3000 m
<b>Electromechanical environmental condition</b>	E2
<b>Mechanical environmental condition</b>	M2



Note: R.H. < 90 % non-condensing @ 40 °C / 104 °F.

**Power Supply**

<b>Type</b>	Self-powered by ESYBUS
<b>Range</b>	15 to 20 V DC
<b>Consumption</b>	<15 mA



**Compatibility and conformity**

<b>Dir- ectives</b>	<p><b>RED</b> 2014/53/EU  <b>RoHS</b> 2011/65/EU</p>
<b>Stand- ards</b>	<p><b>Radio:</b> EN 300 328 V2.2.2  <b>EMC (Electro Magnetic Compatibility):</b> EN 301 489-1 V2.2.3, EN 301 489-17 V3.2.4, EN 62052-11.2021  <b>Safety:</b> EN IEC 61010-1  <b>Health:</b> EN 62311:2020  <b>Metrology:</b> EN IEC 62053-22, EN IEC 62053-23  <b>FCC (USA) Radio Emission:</b> FCC CFR title 47 Part 15C, FCC CFR title 47 Part 2.1091  <b>IC (canadian) radio emission:</b> ISED RSS-247 Issue 3;                  ISED RSS-102 Issue 5</p>
<b>Appro- vals</b>	 

**Available measurements**

Active energy	Unit	System	Phase
Imported (+) Total	kWh+	•	•
Exported (-) Total	kWh-	•	•
Imported (+) Total by tariff (t1, t2)	kWh+	•	-
Reactive energy	Unit	System	Phase
Imported (+) Total	kvarh+	•	•
Exported (-) Total	kvarh-	•	•
Quadrant I, II, III, IV	kvarh	•	-
Apparent energy	Unit	System	Phase
Total	kVAh	•	-
Run hour meter	Unit	System	Phase
Total (kWh+)	hh:mm	•	-
Total (kWh-)	hh:mm -	•	-
Total ON time	hh:mm	•	-
Electrical variable	Unit	System	Phase
Current	A	•	•
Neutral current	A	•	-
Active power	W	•	•
Apparent power	VA	•	•
Reactive power	Var	•	•
Power factor	PF	•	•
THD current*	THD A %	-	•

\*Up to 31<sup>st</sup> harmonic

**Variables update settings**

The table below shows the variables / counters update time according to the number of ESY modules connected.

Number of connected ESY									
1	2	3	4	5	6	7	8	9	10
<100 ms	<150 ms	<200 ms	<250 ms	<300 ms	<350 ms	<400 ms	<450 ms	<500 ms	<550 ms

## Electrical specifications





Electrical system	
Managed electrical system	Two single-phase systems
	Three single-phase systems
	Single-phase (2-wire)
	Two-phase (3-wire)
	Three-phase with neutral (4-wire)
	Three-phase without neutral (3-wire)

Voltage inputs	
Voltage connection	Direct
Rated voltage L-N (from $U_n$ min. to $U_n$ max.)	120 to 277 V
Rated voltage L-L (from $U_n$ min. to $U_n$ max.)	208 to 480 V
Voltage tolerance	From 0.8 to 1.15 $U_n$
Overload	Continuous: 1.15 $U_n$ max.
Input impedance	Refer to "Power supply"
Frequency	From 45 to 65 Hz

**Note:** ESY can be also installed in a wild-leg system (three phases, four-Delta wires), where one of the phase-neutral voltages is higher than the other two.

Current inputs	AV5	MV5
Current connection	Via CT	Via 333 mV current sensor
CT transformation ratio	2000 max.	-
Primary current	10 kA max.	10 kA max.
Rated current ( $I_n$ ) input	5 A	333 mV
Minimum current ( $I_{min}$ )	0.05 A	0.01 $I_n$ (0.03 V)
Maximum current ( $I_{max}$ )	6 A	1.2 $I_n$ (0.4 V)
Start-up current ( $I_{st}$ )	5 mA	0.001 $I_n$ (0.003 V)
Overload	For 500 ms: 20 $I_{max}$ (120 A)	For 500 ms: 8 V
Input impedance	< 0.3 VA	100 k $\Omega$
Crest factor	3	1.414 @ $I_{max}$
Measurement type	by means of internal shunts	with external current sensors

## LED

LED	Colour	Function	Description
LED 1 	Green	Module Status	Slow flashing: connected but not configured Fast flashing: connected and configuration in progress ON: properly addressed and configured
LED 2 	Yellow	Communication Status	OFF: not communicating Flashing: address conflict or communication problems ON: communication is properly working
LED 3 	Red	Module Diagnostic	OFF: no problem ON: CRC issues Slow flashing: voltage drop issue Fast flashing: over-current issue
LED 4 	Red	kWh Pulses	kWh pulses of the sum of the current channels, not dependent on the configured system (e.g. if a module is configured as 3.1P, the pulse is still related to the sum of the channels). OFF if module is not configured.

## Connection Diagrams

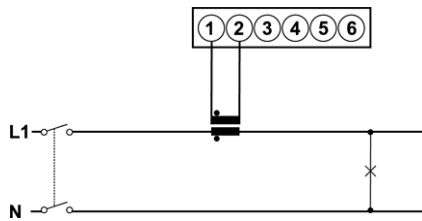

1-CT connection, 1-ph, 2-wire

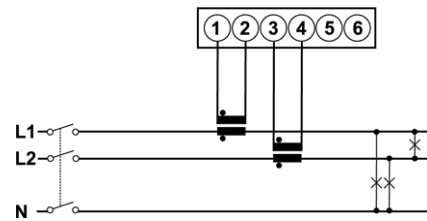

2-CT connection, 2-ph, 3-wire

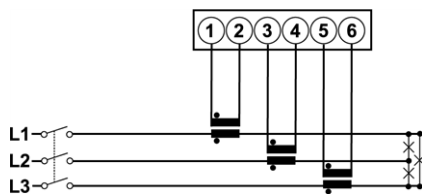

Three-phase without neutral (3-wire)

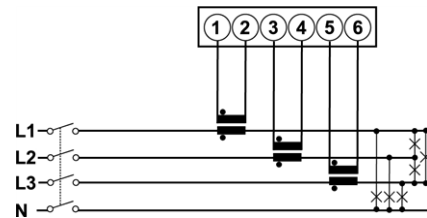

Three-phase with neutral (4-wire)



COPYRIG12T ©2026

Content subject to change. Download the updated version:

[www.gavazziautomation.com](http://www.gavazziautomation.com)