



This Phoenix™ series welding helmet features a wide panoramic view, large 15.3 sq.in center auto-darkening filter (ADF), fixed shade 9 side windows, an integrated 2-speed fan to reduce heat & moisture buildup, auto-work light for quick weld inspection, and large external buttons & LCD with bright status LED indicators. Select fan, work light and grind settings without the need to access LCD panel for uninterrupted use. This welding helmet can also be attached to a hard hat via optional adapter.

Standards: USA: ANSI Z87.1+ (2020) Canada: CSA Z94.3 (2020)

CONTENTS

- Panoramic Welding helmet (contains CR2450 coin cell battery)
- 2 replacement outer shields (KWHOSHIELD)
- 2 replacement inner shields (KWHISHIELD)
- 29025 Modular rechargeable Li-ion battery
- 20" (51 cm) USB-A to USB-C charging cable
- Quick-start guide

HELMET SPECIFICATIONS

- **Operating Temperature:** 32°F to 122°F (0°C to 50°C), 0% to 90% relative non-condensing humidity
- **Storage Temperature:** -22°F to 140°F (-30°C to 60°C), 0% to 90% relative non-condensing humidity
- **Power Supply:** Solar cell with coin cell battery
- **ADF Battery Type:** 1× CR2450 3V Coin Cell
- **ADF Viewing Area:** 3.91" × 3.63" (99 × 92 mm)
- **Side Window Viewing Area:** 2.80" × 3.50" (71 × 89 mm)
- **UV Protection:** U6 (per ANSI Z87.1)
- **Arc Sensors:** 4 Sensors
- **Light State Shade:** Shade 3
- **Variable Welding Shades:** Shade 3 to Shade 14 in half-shade increments
- **Fan Modes:** Low and High
- **Work Light Modes:** Auto (light turns off while welding) and Always-On
- **Low Battery Warning:** Red Light on ADF
- **Grind Warning:** Green Light (Blinking) on ADF
- **Auto Work Light Indicator:** Yellow Light on ADF
- **Power On/Off:** Fully Automatic
- **Light to Dark Switching Time:** 0.00005 seconds (1/20,000 second)
- **Dark to Light Switching Time:** 0.1 to 1.9 seconds
- **Sensitivity Control:** 1 (least sensitive) to 9 (most sensitive)
- **Dimensions:** 13.9" × 11" × 8.8" (353 × 279 × 224mm)
- **Weight (without 29025 battery):** 1.98lb (897g)
- **Drop Protection:** 4.92' (1.5m)
- **Standards:** ANSI Z87.1+ (2020), CSA Z94.3 (2020), UL 507 (2017), CSA C22.2 (2018), UL 4200

Specifications subject to change.

29025 BATTERY SPECIFICATIONS

- **Cell Type:** 18650 Lithium-Ion
- **Capacity:** 3350mAh (12.06Wh)
- **Input USB-C (each):** 5V DC, 1.2A
- **Input USB-C (total):** 5V DC, 1.2A
- **Output USB-C (each):** 5V DC, 1.0A (1800 mAh) up to 2A Max
- **Output USB-C (total):** 5V DC, 1.0A (1800 mAh) up to 2A Max
- **Total Output Power:** 10 W Max.
- **Full Charge Time:** Approx. 4 hours, based on charger output
- **Shelf Life:** Charge every 3 months
- **Charging Requirements:** 5V DC, 2A recommended at 77°F (25°C)
- **Operating Temperature:** -4° to 122°F (-20° to 50°C)
- **Charging Temperature:** 32° to 113°F (0° to 45°C)
- **Storage Temperature (up to 3 months):** 14° to 104°F (-10° to 40°C)
- **Relative Humidity:** <60% non-condensing
- **Dimensions:** 3.5" × 1.7" × 2.1" (88.9 × 43.2 × 53.3 mm)
- **Weight (battery only):** 4.19 oz. (119 g)
- **Drop Protection:** 6.5' (2 m)
- **Ingress Protection (IP) Rating:** IP54
- **Standards:** UN38.3, DOE/CEC, NRCAN
Conforms To UL STD. 2054, 1642, 62368-1, UL SUBJECT 2056
Certified To CSA STD. C22.2 NO. 62368-1

Specifications subject to change.

HELMET WARNINGS

Consult your site safety supervisor prior to using this product. Ensure it meets the standards for the job. Read and understand the warning label affixed to welding helmet (do not remove this label).

WARNING! BEFORE USE: READ ALL INSTRUCTIONS OR RISK SERIOUS INJURY OR DEATH. DO NOT REMOVE LABEL.

- Inspect the welding helmet, headgear, and accessories frequently and immediately replace worn or damaged parts before using.
- Pitted or scratched outer lenses reduce vision clarity, severely reduce impact protection, and should be replaced immediately to prevent injury.
- Welding helmets do not provide unlimited eye, ear, and face protection. Other protective equipment/apparel is recommended to be used with helmet when necessary.
- Arc rays can burn eyes and skin.
- NOT for Laser Welding Processes.
- Use enough ventilation or exhaust at the arc, or both, to keep fumes and gases from your breathing zone and general area.
- Before ANY welding or cutting operation, make sure the shade level settings offered on this helmet are adequate, consult your safety supervisor if unsure.
- DO NOT use paints, solvents, chemicals, insect repellent, adhesives, gasoline, or harsh cleaning agents on any part of the welding helmet and headgear. Doing so can lessen impact and penetration protection, degrade optical clarity, fit, and comfort.

- Wear protective clothing, gloves, shoes, and caps made from clean, durable, flame-resistant material (leather and heavy cotton or similar).
- STOP WELDING IMMEDIATELY if the auto-darkening lens does not darken when the arc is struck or behaves abnormally.
- DO NOT expose suspension and padding to open flame.
- ELECTRICAL WARNING: Avoid areas where the chance of electrical shock exists.
- If the helmet sustains major impact, STOP and inspect for damage. Remove from service immediately if cracks and punctures are seen on the shell.
- DO NOT use without the outer lens installed.
- DO NOT use this helmet while working in explosive or corrosive environments.
- DO NOT use for overhead welding unless additional measures to protect from arc rays, spatter, and other hazards are in place.
- Integrated fan only maintains air circulation to reduce heat and moisture buildup under helmet - it does NOT filter smoke, fumes, or vapors. If ventilation is inadequate, wear an approved respirator suitable for the task.
- DO NOT weld near cleaning, degreasing, and spraying operations. The heat and rays generated by the arc can react with vapors to form toxic and irritating gases.
- NEVER alter, puncture, modify or engrave the shell, suspension or any of the components.
- Exposure to direct sunlight, corrosive environments, and/or extreme temperatures below -40°F (-40°C) or above 120°F (49°C) can lessen the ability of the shell and protective lens to withstand impact and penetration.
- Attach ONLY approved Klein Tools accessories to the suspension mount.
- When the red low battery indicator appears on the auto-darkening filter, STOP and immediately replace CR2450 coin cell battery.
- Read and understand the Safety Data Sheets (SDS) for adhesives, coatings, cleaners, consumables, coolants, degreasers, fluxes, and metals.

COIN CELL BATTERY WARNINGS

<p>WARNING</p> <ul style="list-style-type: none"> INGESTION HAZARD: This product contains a button cell or coin battery. DEATH or serious injury can occur if ingested. A swallowed button cell or coin battery can cause Internal Chemical Burns in as little as 2 hours. KEEP new and used batteries OUT OF REACH of CHILDREN. Seek immediate medical attention if a battery is suspected to be swallowed or inserted inside any part of the body. 	
---	---

- Contains 1× CR2450, 3V Nominal
- Remove and immediately recycle or dispose of used batteries according to local regulations and keep away from children. DO NOT dispose of batteries in household trash or incinerate.
- Call a local poison control center for treatment information.
- Even used batteries may cause severe injury or death.
- Non-rechargeable batteries are not to be recharged.
- Do not force discharge, recharge, disassemble, heat above (manufacturer's specified temperature rating) or incinerate. Doing so may result in injury due to venting, leakage or explosion resulting in chemical burns.
- Ensure the batteries are installed correctly according to polarity (+ and -).
- Do not mix old and new batteries, different brands or types of batteries, such as alkaline, carbon-zinc, or rechargeable batteries.
- Remove and immediately recycle or dispose of batteries from equipment not used for an extended period of time according to local regulations.
- Always completely secure the battery compartment. If the battery compartment does not close securely, stop using the product, remove the batteries, and keep them away from children.

HELMET FEATURE DETAILS

- 1 Smart Auto Work Light
- 2 Smart Auto Work Light Power Button
- 3 Integrated Cooling Fan with Filter
- 4 Cooling Fan Power Button
- 5 Suspension Adjust/Release Button (x2)
- 6 Grind Mode Button
- 7 Outer Shield
- 8 Outer Shield Release Tab (x2)
- 9 Fan/Work Light Circuit Housing
- 10 Coin Cell Battery Housing
- 11 LCD with Control Panel
- 12 Center Auto-Darkening Filter (ADF)
- 13 Fixed Shade 9 Side Windows (x2)
- 14 Fan, Work light, and Auto-Darkening Filter (ADF) Connector Ports

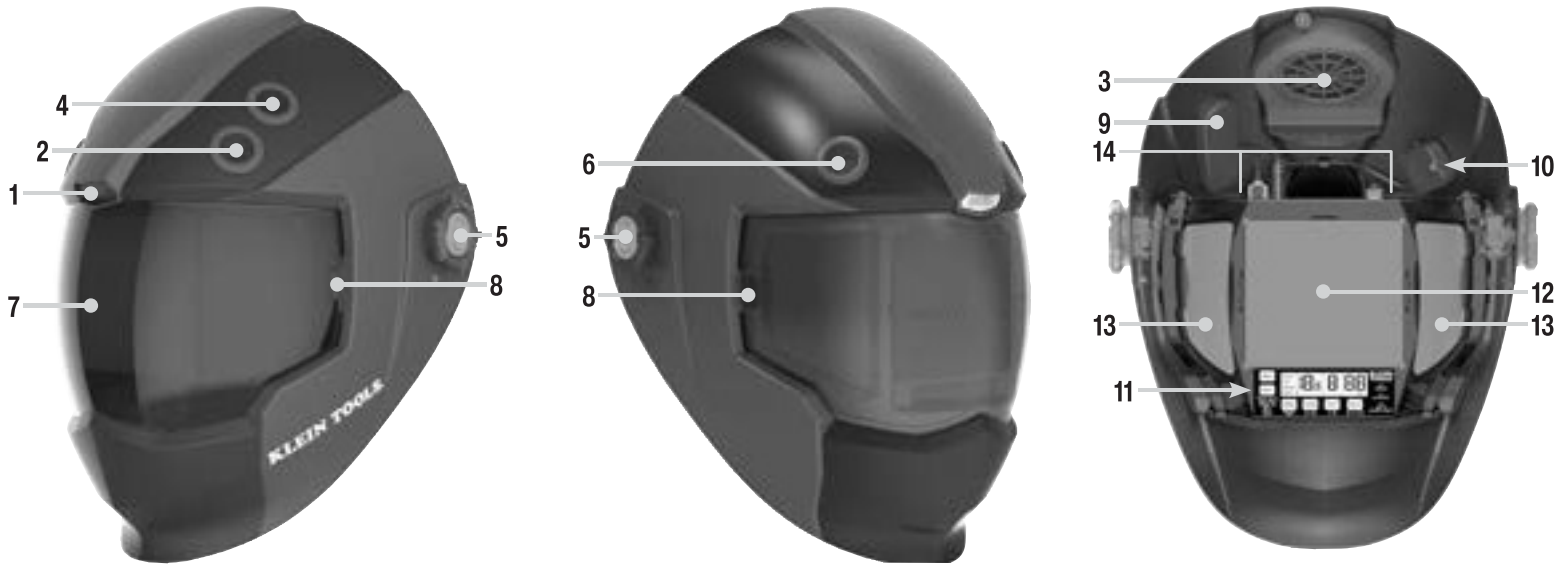

HEADGEAR SUSPENSION FEATURE DETAILS

- 15 Removable Rechargeable Battery Mount
- 16 Replaceable, Machine Washable Sweatband
- 17 Ratchet Adjustment Knob
- 18 Rear Adjustable Strap
- 19 Suspension Ratchet Pivot
- 20 Helmet Angle Adjustment Tab
- 21 Helmet Horizontal Adjustment Button
- 22 Suspension Release Tab
- 23 Helmet Tension Set/Suspension Detachment Knob
- 24 Removable Top Pad
- 25 Top Adjustable Strap
- 26 Front Adjustable Strap
- 27 Rear Neck Pad
- 28 Locating Bracket

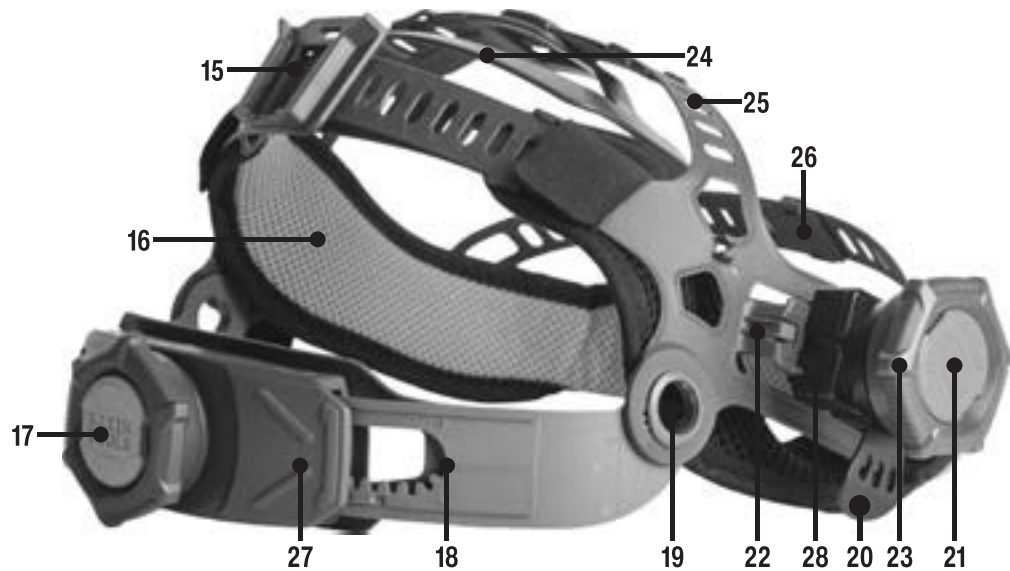

29025 MODULAR BATTERY FEATURE DETAILS

- 29 Battery Status Button
- 30 Battery Release Tab
- 31 Battery Status LED Indicator
- 32 USB-C Input/Output Ports (x2)
- 33 Klein Accessory Mount
- 34 Magnet

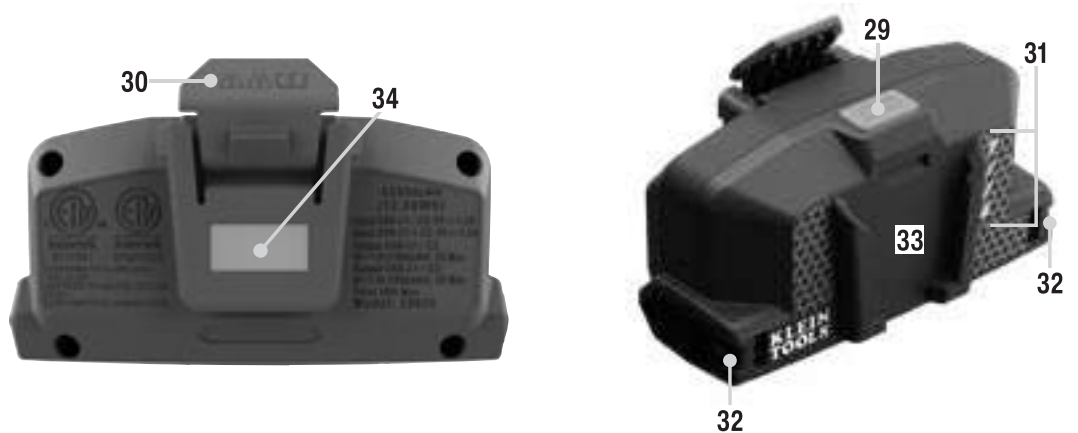

NOTE: Battery is equipped with two USB-C input/output ports designed to power small accessories. The battery on the welding helmet powers only the work light and fan. It does not power the helmet's ADF electronics. Please consult the battery manual included for information on the battery.

SETUP - HEADGEAR SUSPENSION

Unpack the helmet and check the fit straight out of the box to identify what needs to be adjusted:

ADJUSTING HELMET'S HORIZONTAL POSITION

Push on the Helmet horizontal adjustment buttons (21) on each side and slide the suspension forward or backward into one of the four available positions as needed until a click is heard, then match the other side. Try on the helmet and repeat as necessary until the optimal position is found.

ADJUSTING WELDING TILT ANGLE

1. Locate the helmet Helmet Angle Adjustment tab (20) on each side of the installed suspension. Loosen the helmet's tension by turning the Helmet Tension Set/Suspension Detachment Knob (23). This will ensure the tab can be lifted for repositioning.
2. Gently lift the tab to clear the locating pin and reposition on the desired slot on the tab. This will be the angle of the helmet in the welding position. This is especially important if you have magnifying accessory (i.e. Klein Tools Cat. Nos. KWHMAG15 or KWHMAG20) *installed on the ADF (12)*.

ADJUSTING STRAPS

The Rear (18), Top (25) and Front (26) Straps can be adjusted by releasing the tabs from the strap slots or holes and snapping into the new slot location of choice. Ensure that all straps are contacting your head while welding. **NOTE:** *Each strap location is marked with number. It is recommended that you mark the strap and/or record each location number for future reference.*

SETUP - HARD HAT-MOUNTED ADAPTER

HARD HAT ADAPTER (Cat. No. KWHADAPTER)

The Hard Hat Adapter (sold separately) is required to mount the welding helmet to a cap-style hard hat or safety helmet.

NOTE: *The Hard Hat Adapter works with cap-style hard hats only in reverse-donned orientation. Refer to hard hat instruction manual under REVERSE DONNING to properly configure before installing. Consult with your Safety Manager to ensure your cap-style hard hat is approved to be worn in the reverse-donned orientation prior to installation.*

NOTE: *Neither the Hard Hat Adapter nor Welding Helmet can be used with full-brim hard hats.*

REMOVING / REPLACING HEADGEAR SUSPENSION [CLICK HERE TO WATCH VIDEO](#)

1. Press and hold the Helmet Horizontal Adjustment Button (21) and slide the head mounted suspension forward, then press the Suspension Release Tab (22) and slide headgear fully out of the Locating Bracket (28). Repeat on both sides.
2. The replacement headgear includes helmet mounting hardware identical to that included with the Welding Helmet. Either set of hardware may be used. If opting to use the hardware included with the suspension, unscrew and remove the Helmet Tension Set/Suspension Detachment Knob (23) from the Locating Bracket (28). Repeat on both sides.
3. Seat the Helmet Angle Adjustment Tab (20) into the Locating Bracket (28), ensuring it seats flat.
4. Ensure the locating pin seats into one of the three slots in the Helmet Angle Adjustment Tab (20). Insert the square post into the shell. Hold the Locating Bracket (28) in place and install the Helmet Tension Set/Suspension Detachment Knob (23) until the assembly is tight. Repeat on both sides. **NOTE:** *Angle Adjustment Tabs (20) are marked with an "L" and "R" for proper orientation during installation.*
5. Install the head mounted suspension by pressing the Helmet Horizontal Adjustment Button (21) and backing the suspension into the Locating Bracket (28) from the front until the desired position is reached. Release the Helmet Horizontal Adjustment Button (21) to lock into position. Repeat on both sides. Ensure each side is in the same position.

INSTALLING HARD HAT ADAPTER [CLICK HERE TO WATCH VIDEO](#)

1. The Hard Hat Adapter includes helmet mounting hardware identical to that included with the Welding Helmet. Either set of hardware may be used. If opting to use the hardware included with the Hard Hat Adapter, unscrew and remove the Helmet Tension Set/Suspension Detachment Knob (23) from the Locating Bracket (28). Repeat on both sides.
2. If installing new mounting hardware to the welding helmet, seat the Helmet Angle Adjustment Tab (20) into the Locating Bracket (28), ensuring it seats flat. Ensure the locating pin seats into one of the three slots in the Helmet Angle Adjustment Tab (20). Insert the square post into the shell. Hold the Locating Bracket (28) in place and install the Helmet Tension Set/Suspension Detachment Knob (23) until the assembly is tight. Repeat on both sides. **NOTE:** *Angle Adjustment Tabs (20) are marked with an "L" and "R" for proper orientation during installation.*
3. Orient the expansion spring to face the Center Auto-Darkening Filter (ADF) (12).
4. Install the Hard Hat Adapter from the back onto the Locating Bracket (28). Press and hold the Helmet Horizontal Adjustment Button (21) and move into one of the two available positions. Release the Helmet Horizontal Adjustment Button (21) to lock in place (you should hear a click). Ensure each side is in the same position.
5. With the hard hat centered and facing forward, slide the Hard Hat Adapter over the top of the hard hat and snap each mounting tab under the brim of the hard hat.
6. To set the angle of the welding position of the Welding Helmet, gently lift the Helmet Angle Adjustment Tab (20) to clear the locating pin and reposition into the desired slot on the tab. Repeat on both sides, ensuring each side is in the same position. **NOTE:** *This is especially important if you have magnifying accessory (Cat. Nos. KWHMAG15 & KWHMAG20) installed on the ADF (12).*

NOTE: *The Hard Hat Adapter may also be installed onto the hard hat first, installing the Welding Helmet afterward.*

SETUP - HARD HAT-MOUNTED SUSPENSION

HARD HAT Adapter (Cat. No. KWHADAPTER)

The Hard Hat Adapter (sold separately) is required to mount the welding helmet to a cap-style hard hat or safety helmet.

NOTE: The Hard Hat Adapter works with cap-style hard hats only in reverse-donned orientation. Refer to hard hat instruction manual under REVERSE DONNING to properly configure before installing. Be sure your cap-style hard hat is approved to be worn in the reverse-donned orientation.

NOTE: Neither the Hard Hat Adapter nor Welding Helmet can be used with full-brim hard hats.

REMOVING HEADGEAR

Press and hold the Helmet Horizontal Adjustment Button (21) and slide suspension forward, then press the Suspension Release Tab (22) and slide suspension fully out of Locating Bracket (28).

INSTALLING HARD HAT ADAPTER [CLICK HERE TO WATCH VIDEO](#)

1. The Hard Hat Adapter includes helmet mounting hardware identical to that included with the Welding Helmet. Either set of hardware may be used. If opting to use the hardware included with the Hard Hat Adapter, unscrew and remove the Helmet Tension Set/Suspension Detachment Knob (23) from the Locating Bracket (28). Repeat on both sides.
2. If installing new mounting hardware to the welding helmet, seat the Helmet Angle Adjustment Tab (20) into the Locating Bracket (28), ensuring it seats flat. Ensure the locating pin seats into one of the three slots in the Helmet Angle Adjustment Tab (20). Insert the square post into the shell. Hold the Locating Bracket (28) in place and install the Helmet Tension Set/Suspension Detachment Knob (23) until the assembly is tight. Repeat on both sides. **NOTE:** Angle Adjustment Tabs (20) are marked with an "L" and "R" for proper orientation during installation.
3. Orient the expansion spring to face the Center Auto-Darkening Filter (ADF) (12).
4. Install the Hard Hat Adapter from the back onto the Locating Bracket (28). Press and hold the Helmet Horizontal Adjustment Button (21) and move into one of the two available positions. Release the Helmet Horizontal Adjustment Button (21) to lock in place (you should hear a click). Ensure each side is in the same position.
5. With the hard hat centered and facing forward, slide the Hard Hat Adapter over the top of the hard hat and snap each mounting tab under the brim of the hard hat.
6. To set the angle of the welding position of the Welding Helmet, gently lift the Helmet Angle Adjustment Tab (20) to clear the locating pin and reposition into the desired slot on the tab. Repeat on both sides, ensuring each side is in the same position. **NOTE:** This is especially important if you have magnifying accessory (Cat. Nos. KWHMAG15 & KWHMAG20) installed on the ADF (12).

NOTE: The Hard Hat Adapter may also be installed onto the hard hat first, installing the Welding Helmet afterward.

FIG. A

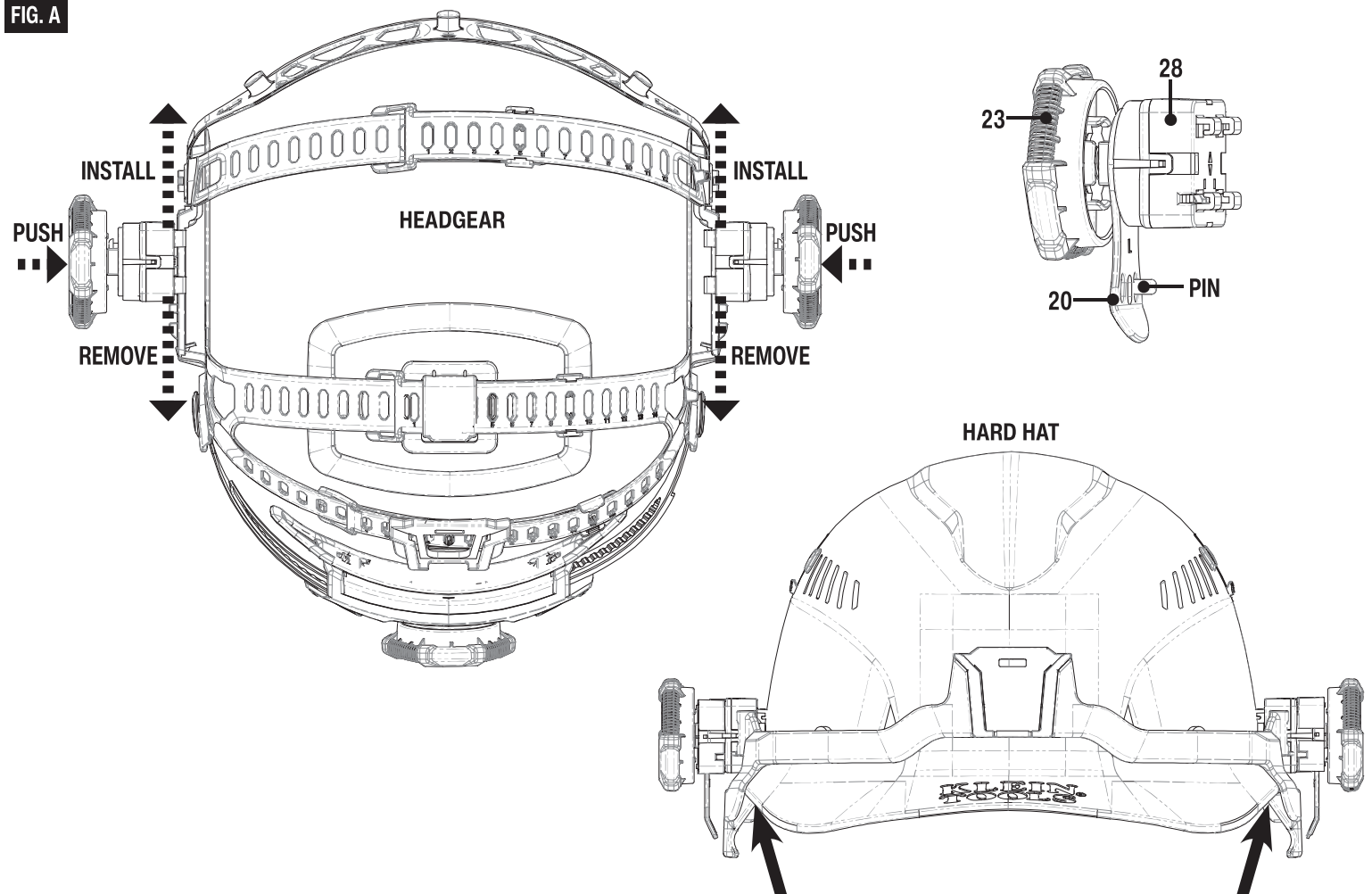

SETUP - WELDING PARAMETERS

The 60141 Welding Helmet can be set up for multiple welding operations:

- Shield metal arc welding (SMAW/Stick)
- Gas metal arc welding (GMAW/MIG)
- Gas tungsten arc welding (GTAW/TIG)
- Plasma arc cutting (PAC)
- Plasma arc welding (PAW)
- Grinding
- Oxygen cutting (OC) and oxygen welding (OW)

Below are recommended settings for various setups. A supplemental lens shade selection table (ANSI Z49.1:2012) can also be referenced, if unsure. It is recommended to start with a shade that is too dark to see the weld zone, then gradually adjust to a lighter shade that gives a sufficient view of the weld zone without going below the minimum protective shade number.*

PROCESS	ELECTRODE SIZE	ARC CURRENT	MINIMUM PROTECTIVE SHADE NO.	SUGGESTED SHADE NO. (COMFORT)*
Shielded Metal Arc Welding (SMAW)	Less than 3/32 (2.4mm)	Less than 60A	7	--
	3/32 to 5/32 (2.4 to 4.0mm)	60A to 160A	8	10
	5/32 to 1/4 (4.0 to 6.4mm)	160A to 250A	10	12
	More than 1/4 (6.4mm)	250A to 550A	11	14
Gas Metal Arc Welding (GMAW)	--	Less than 60A	7	--
Flux Cored Arc Welding (FCAW)		60A to 160A	10	11
		160A to 250A	10	12
		250A to 550A	10	14
Gas Tungsten Arc Welding (TIG)	--	Less than 50A	8	10
		50A to 150A	8	12
		150A to 500A	10	14
Air Carbon Arc Cutting (CAC-A)	Light	Less than 500A	10	12
	Heavy	500A to 1000A	11	14
Plasma Arc Cutting (PAC)	--	Less than 20A	4	4
		20A to 40A	5	5
		40A to 60A	6	6
		60A to 80A	8	8
		80A to 300A	8	9
		300A to 400A	9	12
	400A to 800A	10	14	
Plasma Arc Welding (PAW)	N/A	Less than 20A	6	6 to 8
		20A to 100A	8	10
		100A to 400A	10	12
		400A to 800A	11	14

⚠ CAUTION: Some processes such as oxygen cutting (OC) or oxygen welding (OW) may require a yellow filter lens cover to absorb yellow light. Consult your Safety Supervisor.

SETUP - WELDING PARAMETERS

A button and display functionality guide can be found on the inside of the Welding Helmet shell (FIG. B).

FIG. B

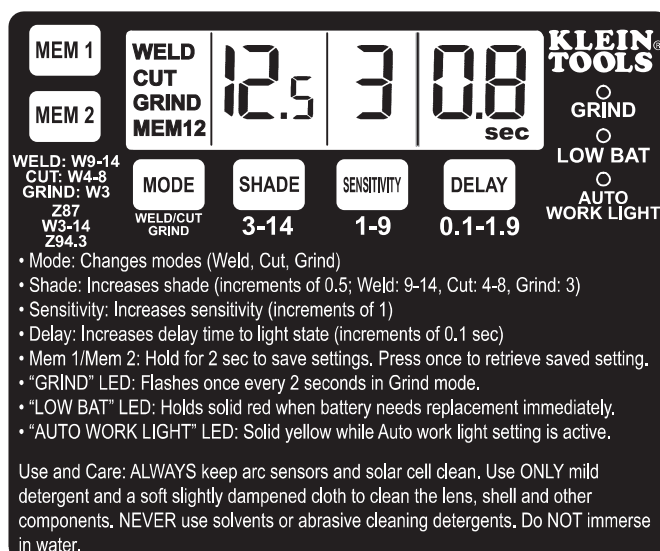
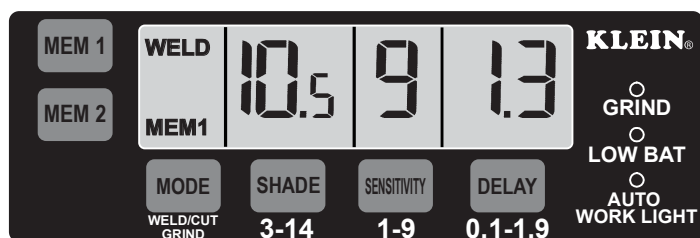

LCD CONTROL PANEL [CLICK HERE TO WATCH VIDEO](#)

- Press the MODE button on the Control Panel (11) to select WELD, CUT, or GRIND mode.
- In WELD and CUT modes, press the SHADE, SENSITIVITY, and DELAY buttons to select desired setting for each parameter.
- In GRIND mode, the display will default to Shade 3, and the green GRIND LED indicator will blink continuously. **NOTE:** GRIND mode may be selected via the MODE button, or the external GRIND Button (6).

SAVING AND RECALLING SETUP

Regularly used settings (up to 2) can be saved as presets using the MEM1 and MEM2 buttons on the Control Panel (11).

- Once all desired settings have been established, press and hold either the MEM1 or MEM2 button until "MEM1" or "MEM2" appears on the LCD (~2 seconds) to save those settings as a preset.
- Press the MEM1 or MEM2 button to recall the preset settings.
- Setting changes made after a preset is selected will override the parameters of the preset, and "MEM1" or "MEM2" will disappear from the LCD. Press the MEM1 or MEM2 button at any time to recall the preset settings.
- Pressing and holding either the MEM1 or MEM2 button will create a new preset, overwriting any existing presets.

SMART AUTO WORK LIGHT POWER BUTTON

Press the Smart Auto Work Light Power Button (2) to toggle through Auto, On, and Off settings:

- The first press of the Smart Auto Work Light Power Button (2) powers on the Smart Auto Work Light (1) in AUTO mode. In this mode, the work light will turn off when an arc is detected. The AUTO WORK LIGHT LED indicator on the Control Panel (11) will illuminate yellow while in this mode.
- The second press of the Smart Auto Work Light Power Button (2) powers on the Smart Auto Work Light (1) in ON mode. In this mode the work light will remain on continuously until powered off.
- The third press of the Smart Auto Work Light Power Button (2) powers off the Smart Auto Work Light (1).

COOLING FAN POWER BUTTON

Press the Cooling Fan Power Button (4) to toggle through High, Low, and Off settings.

GRIND MODE BUTTON

- Press and hold the external Grind Mode Button (6) for 2 seconds to enter the ADF (12) into Grind Mode. The GRIND LED indicator on the Control Panel (11) will blink green, and the ADF (12) will lock at Shade 3 and will NOT darken when welding arcs are detected. To exit Grind Mode, press and hold the external Grind Mode Button (6) for 2 seconds, or adjust the mode on the Control Panel (11).
- Press the external Grind Mode Button (6) to momentarily darken the ADF (12) to your set shade level. This serves as a test function to ensure your ADF (12) is darkening properly.

LOW BATTERY

When the CR2450 coin cell battery (10) is low, the LOW BAT LED indicator on the Control Panel (11) will illuminate red. When this occurs, immediately suspend use of the Welding Helmet and replace battery before resuming use. The Auto-Darkening Filter (ADF) (12) CANNOT operate without this battery and will become non-functional. **NOTE:** The the LOW BAT LED indicator is for the ADF CR2450 coin cell battery ONLY, it does NOT indicate status of the Modular Battery that powers the fan and work light. Refer to the Battery Status Indicator on the Modular Battery to monitor its charge status.

1. Use a #2 Phillips screwdriver to loosen the screw in the Coin Cell Battery Housing (10). **NOTE:** DO NOT use a powered screwdriver to perform this operation.
2. Replace the CR2450 coin cell battery, noting proper polarity.
3. Replace the Coin Cell Battery Housing (10) and secure with screw. Do not over-tighten. **NOTE:** DO NOT use a powered screwdriver to perform this operation.
4. Verify ADF is functional and that the LOW BAT LED Indicator is no longer illuminated prior to resuming use of the Welding Helmet.

REPLACEMENT PARTS

A list of available replacement parts can be found on the inside of the Welding Helmet shell (FIG. C).

FIG. C

KLEIN TOOLS 60141**Replacement Parts:**

Outer Shield 5pk.....KWHOSHIELD
 Inner Shield 5pk.....KWHISHIELD
 Headgear.....KWHSPN
 Sweatband 3pk.....KWHSWTBND
 Hard Hat Adapter.....KWHADAPTER
 Fan.....KWHFAN
 Side Windows.....KWSIDEWIN
 Auto-Darkening Filter.....KWHSCRN
 1.5X Mag. Lens.....KWHMAG15
 2.0X Mag. Lens.....KWHMAG20

OUTER SHIELD (Cat. No. KWHOSHIELD) (FIG. D) [CLICK HERE TO WATCH VIDEO](#)

1. Press either Outer Shield Release Tab (8) and slide the existing Outer Shield (7) forward to remove from Welding Helmet.
2. Snap the replacement Outer Shield (7) onto both Outer Shield Release Tabs (8).

FIG. D

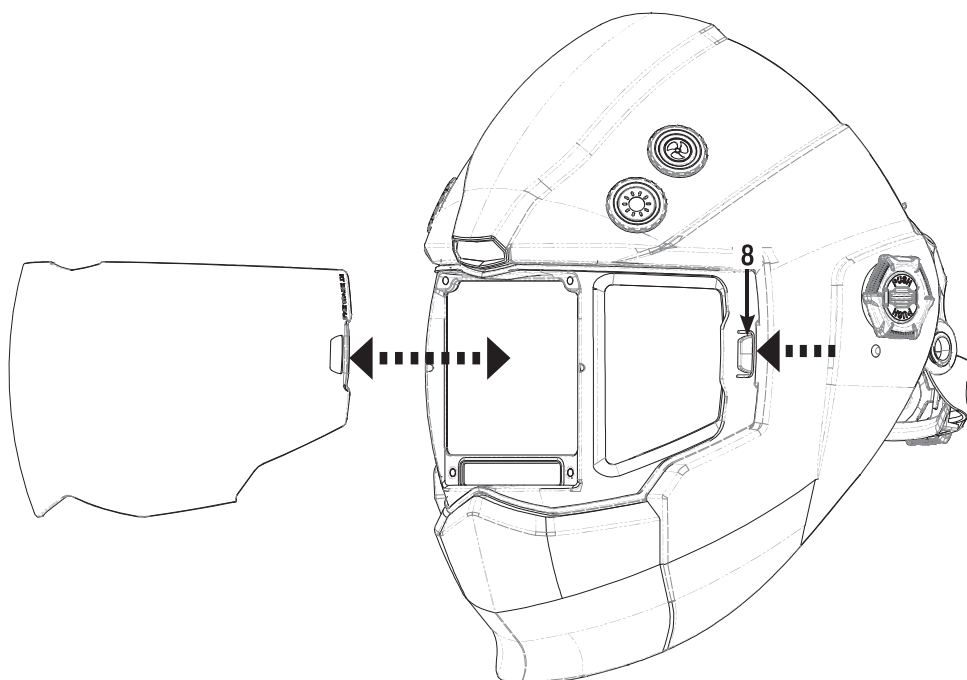
**INNER SHIELD (Cat. No. KWHISHIELD) (FIG. E)**

1. Insert fingernail into the clearance groove and pry out the existing Inner Shield.
2. Insert bottom corners of replacement Inner Shield into the bottom corner tabs, then slightly flex the Inner Shield to insert the top corners into the top corner tabs.

FIG. E

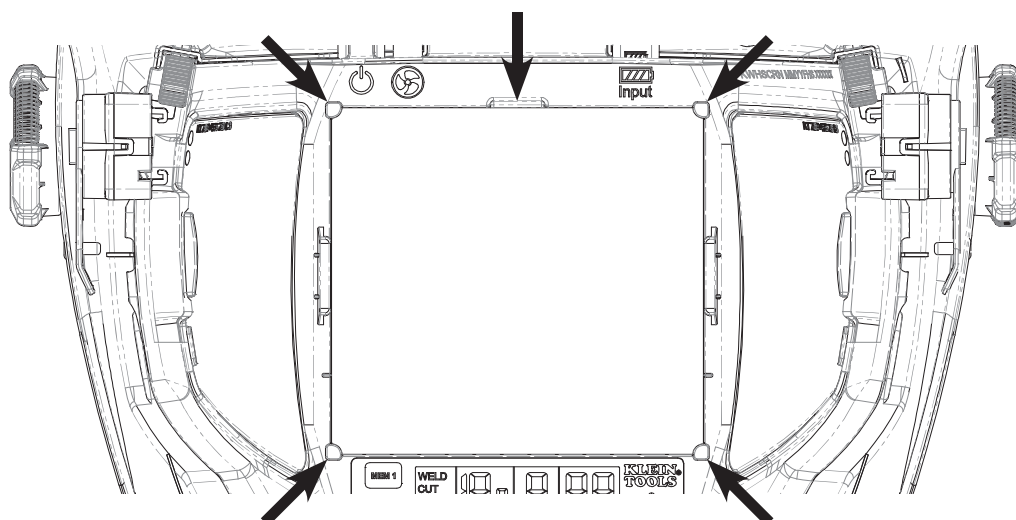

REPLACEMENT PARTS

FAN (Cat. No. KWHFAN) (FIG. F)

1. Disconnect Fan's connector from the ADF Connector Port (14).
2. Use a #2 Phillips screwdriver to loosen the screw in the Fan housing to remove the Fan. **NOTE: DO NOT use a powered screwdriver to perform this operation.**
3. Install replacement Fan, aligning the screw bosses in the fan and the shell, and secure with screw. Do not over-tighten. **NOTE: DO NOT use a powered screwdriver to perform this operation.**
4. Reconnect Fan's connector to the ADF Connector Port (14).
5. Verify fan's functionality by pressing the Cooling Fan Power Button (4) and adjust vent for desired airflow.
6. To access Fan Filter, pry open filter cover and remove filter.
7. Wash filter in warm water with mild detergent and allow to dry thoroughly.
8. Reinstall filter and snap filter cover closed.

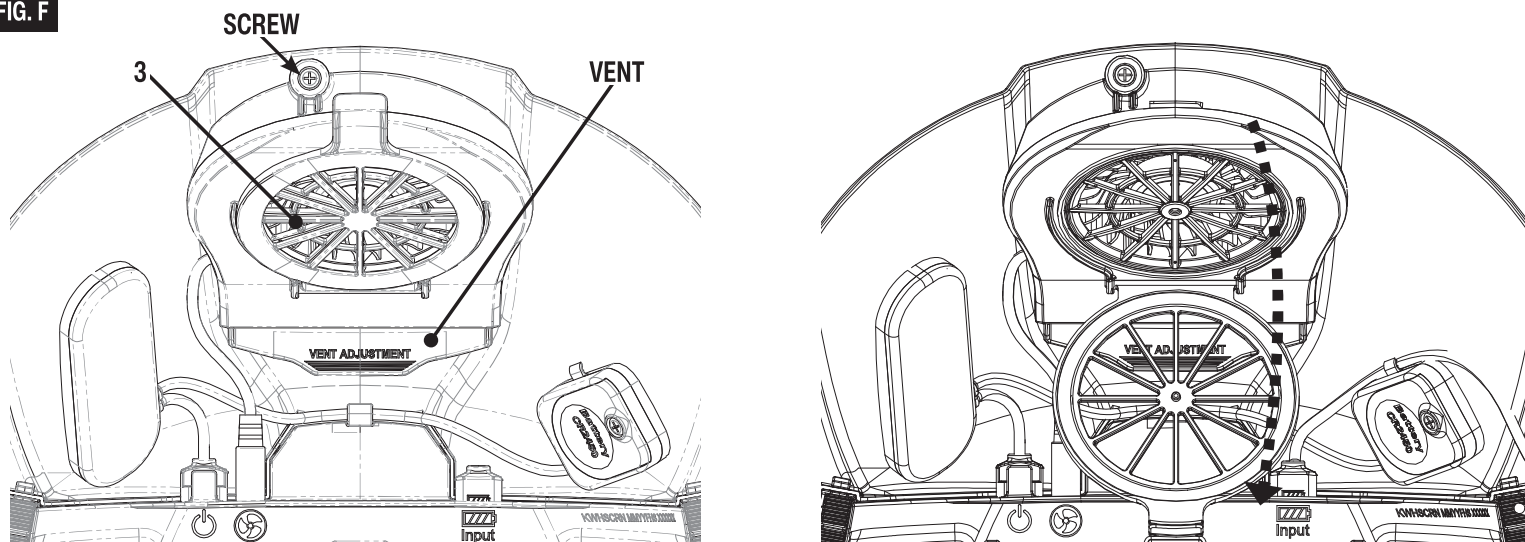
FIG. F**AUTO-DARKENING FILTER (ADF) (Cat. No. KWHSRN) (FIG. G) [CLICK HERE TO WATCH VIDEO](#)**

1. Remove Hard Hat Adapter or head gear suspension from shell (see SETUP section).
2. Disconnect all connectors from the top of the ADF (14).
3. Push the ADF latches down on both sides and gently pull back on the existing ADF's top and lift the ADF to clear the locating slots on the bottom of the shell.
4. Locate replacement ADF into locating slots on the bottom of the shell and gently push the ADF forward until properly seated.
5. Push ADF latches up on both sides up to lock ADF into place.
6. Reconnect all connectors (14).

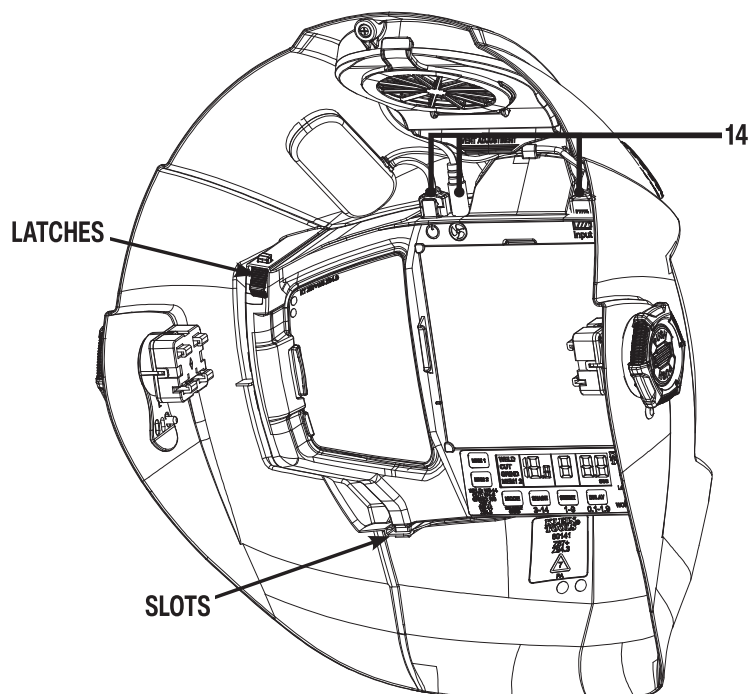
FIG. G

REPLACEMENT PARTS

FIXED SHADE 9 SIDE WINDOWS (Cat. No. KWHSIDEWIN) (FIG. H) [CLICK HERE TO WATCH VIDEO](#)

1. Remove Hard Hat Adapter or head gear suspension from shell (see SETUP section) and Outer Shield (see OUTER SHIELD section).
2. Slide locking tabs back and push Windows from the outside to remove from shell. Repeat on both sides.
3. Insert replacement Windows and slide locking tabs forward. **NOTE:** *Shade 9 Windows can be replaced with the included opaque "blackout" windows, if desired.*

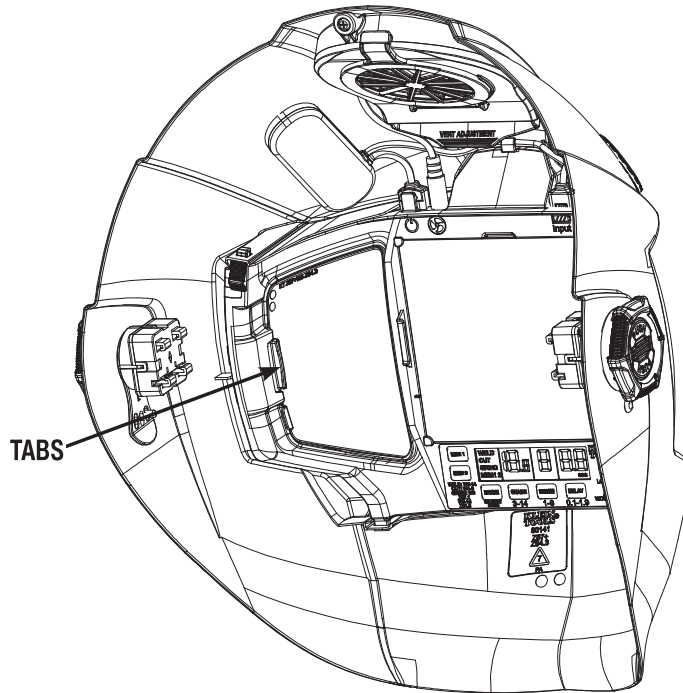

CLEANING

ALWAYS keep arc sensors and solar cell clean. Use ONLY mild detergent and a soft slightly dampened cloth from to clean the lens, shell, and other components. **NEVER use solvents and abrasive cleaning detergents. DO NOT immerse in water.**

STORAGE

When not in use, store in cool environments, free from abrasive vapors and chemicals, and extreme temperature swings.

FCC & IC COMPLIANCE

See this product's page at www.kleintools.com for FCC compliance information.
Canada ICES-003 (B) / NMB-003 (B)

WARRANTY

www.kleintools.com/warranty

DISPOSAL / RECYCLE

Do not place equipment and its accessories in the trash. Items must be properly disposed of in accordance with local regulations. See www.epa.gov/recycle for additional information.

CUSTOMER SERVICE

KLEIN TOOLS, INC.
450 Bond Street Lincolnshire, IL 60069 1-800-553-4676
customerservice@kleintools.com www.kleintools.com