

PROTEK DOUBLE-HINGED FAN PACKAGES



INDUSTRY STANDARDS

UL 508A Listed; File Number E61997
 cUL Listed per CSA C22.2 No. 94; File Number E61997
 Solid Door: Type 3R
 Window Door: Type 1

NEMA / EEMAC: Type 1 or 3R
 IEC 60529, IP30 or IP 32, IK 10

APPLICATION

PROTEK Double-Hinged Fan Package cabinets are an excellent, off-the-shelf choice for mounting 19-in. rack, panel-mounted devices or other electronic equipment. An integral top solar/drip shield and thermostatically-controlled fans provide airflow to cool internal equipment. Cabinets are available in UL Type 3R for outdoor use. A UL Type 1 window version is available for indoor applications. The cabinets are designed to provide both front and rear access to 19-in. rack-mounted equipment, while ensuring protection against water, dirt and other contaminants. PROTEK is an excellent choice for applications where space is at a premium and the only option is wall mounting. PROTEK comes in a broad range of sizes, materials and configurations to meet many demanding applications.

FEATURES

- Front and rear access to 19-in. rack equipment provided by three-part design: door, center section and wall section
- Solid door provides complete physical and visual protection
- Integral top solar/drip shield
- Two thermostatically controlled, long-life, high-performance fans mounted into top
- Window door, made of .25-in. scratch-resistant safety glass and mechanically fastened, provides visual monitoring of internal equipment while maintaining equipment protection
- All seams are fully welded and ground smooth
- Perforated, vented base with internal, expanded metal, serviceable filter
- Door, center section and wall section are provided with ground studs to facilitate proper bonding and grounding of the cabinet
- Premium seamless, foam-in-place gasket prevents contaminants from entering the cabinet
- Keylocking wing knob provides access control to the cabinet; two keys are included with each cabinet
- One set of plated, self-grounding, tapped 10-32 rack angles per EIA universal spacing standards, adjustable front-to-back within the center section of the cabinet
- Additional rack angles in tapped- or square-hole versions can be added to the cabinet
- Wall section welded panel studs which accommodate standard panels (steel and wood available), can be ordered separately

SPECIFICATIONS

- Doors made of 16 gauge; wall and center sections made of 14 gauge steel
- Integral top with two 6-in. fans powered by 120 VAC via cord with standard NEMA plug, provide 230 CFM of airflow
- Window made of .25-in. safety glass
- Rack angles with 10-32 tapped holes per EIA universal standards are made of 12 gauge plated steel
- Incoming air filter made of expanded aluminum
- M6 door and body ground studs are masked from paint
- Twenty 10-32 rack angle equipment mounting screws included with cabinet
- Foam-in-place gasket made of durable polyurethane
- Inline thermostat turns fans on when temperature exceeds 85 F/30 C

FINISH

Pretreated steel coated with light-gray, low-gloss, lightly textured RAL 7035 polyester powder

LOAD RATING

Height	Rating
24 in.	250 lb./113.4 kg
36 in.	300 lb./136.0 kg
48 in.	350 lb./158.7 kg

ACCESSORIES

Locks and handles
 Panels (steel and wood)
 Grounding kits
 Power Distribution Units (PDUs)
 Rack angles

NOTES

- Performance data based on:
- Effective measured airflow provided by integral fans is 272 CFM
 - Delta T or ΔT (Ambient Temperature – Maximum in-cabinet Temperature)
 - Ambient air must be cooler than maximum in-cabinet temperature
 - For applications that have less than a ΔT of 5 F, use PROTEK with AC unit
 - Total Cooling = [Air cooling + Cabinet cooling]
 - Air Cooling [Watts = $.316 \times \text{CFM} \times \Delta T$] Cabinet cooling [Watts = $[(.22 \times \text{Area}) / \Delta T]$

Example: Cabinet height 24 in. x 24 in. deep with ambient temperature 110 F, with a maximum internal cabinet temperature 120 F ($\Delta T = 10$ F). The cabinet and fans will provide a total cooling capability of 762 Watts or 1300 BTU.

(See Performance Chart)

BULLETIN: DWDH2

Performance Chart **Total Cooling in Watts (BTUs)**

Delta T	A=24 in.	A=36 in.	A=48 in.
25F	2237 (7634)	2270 (7747)	2309 (7860)
20F	1789 (6107)	1816 (6197)	1842 (6288)
15F	1342 (4580)	1362 (4648)	1382 (4716)
10F	895 (3054)	908 (3099)	921 (3144)
5F	447 (1527)	454 (1550)	460 (1572)

See Notes on page 1.

Technical Fan Data

Nominal Size	Qty.	Voltage	Amperage 50/60 Hz	Plug	Effective CFM
6 in.	2	120 VAC	.90/.72	Standard NEMA 5-15P	272 (Clean filter)

Standard Product **PROTEK Double-Hinged Solid Door, Type 3R (indoor or outdoor)**

Catalog Number	in./mm	Rack Units	P in./mm	Q in./mm	Optional Steel Panel	Optional Wood Panel	Additional Rack Angles ^a
PTHS242424G3	24.09 x 23.62 x 24.02	12	---	---	CP2020	CP2020W	PTRA24T or PTRA24S
	612 x 600 x 610						
PTHS362424G3	36.30 x 23.62 x 24.02	19	---	---	CP3220	CP3220W	PTRA36T or PTRA36S
	922 x 600 x 610						
PTHS482424G3	48.62 x 23.62 x 24.02	26	---	---	CP4420	CP4420W	PTRA48T or PTRA48S
	1235 x 600 x 610						

Cabinet dimensions do not include integral solar/drip shield and fan top. See dimensional drawing.

^aT=tapped 10-32; S=Square hole (.375 in. x .375 in./10 mm x 10 mm)

Replacement filter part number 10100038



Standard Product **PROTEK Double-Hinged Window Door, Type 1 (indoor only)**

Catalog Number	AxBxC in./mm	Rack Units	P in./mm	Q in./mm	Optional Steel Panel	Optional Wood Panel	Additional Rack Angles ^a
PTHW242424GF	24.09 x 23.62 x 24.02	12	18.25	15.38	CP2020	CP2020W	PTRA24T or PTRA24S
	612 x 600 x 610		464	391			
PTHW362424GF	36.30 x 23.62 x 24.02	19	30.75	15.38	CP3220	CP3220W	PTRA36T or PTRA36S
	922 x 600 x 610		781	391			
PTHW482424GF	48.54 x 23.62 x 24.02	26	42.70	15.38	CP4420	CP4420W	PTRA48T or PTRA48S
	1233 x 600 x 610		1085	391			

Cabinet dimensions do not include integral solar/drip shield and fan top. See dimensional drawing.

^aT=tapped 10-32; S=Square hole (.375 in. x .375 in./10 mm x 10 mm)

Replacement filter part number 10100038



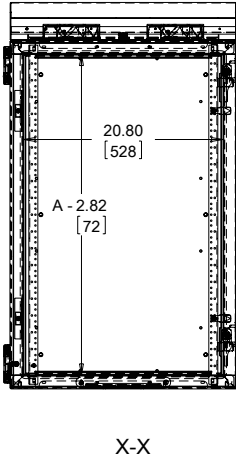
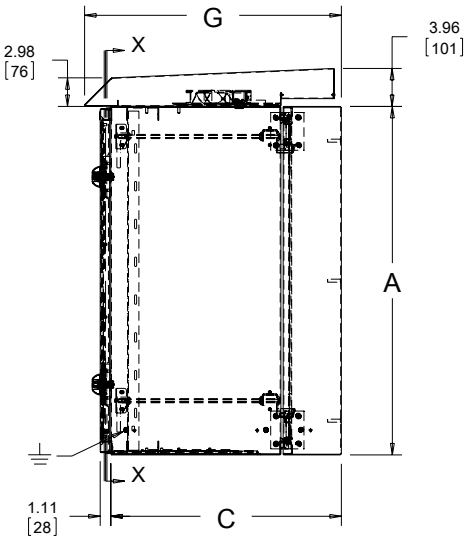
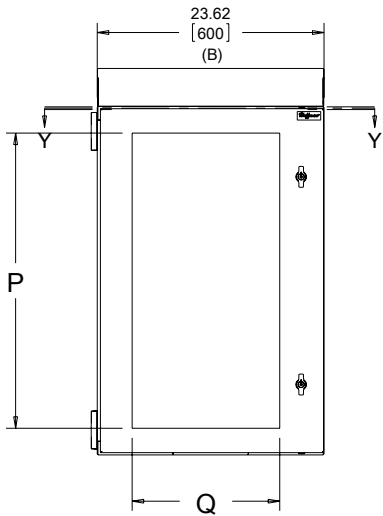
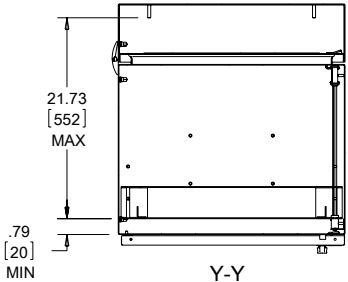

89081447

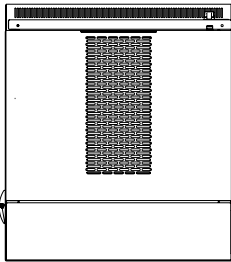

PROTEK WALL-MOUNT CABINET ACCESSORY PANELS

Where equipment mounting space is limited, Accessory Panels increase cabinet capacity by providing a mounting surface for 19-in. equipment and accessories at the back of the cabinet. The panels mount on collar studs provided in the cabinet. Available in painted mild steel.

BULLETIN: CWP, DWDH2

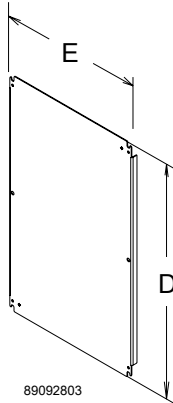

Standard Product

Catalog Number	Panel Size D x E mm/in.	Gauge
CP2014	462 x 310	14
CP2020	462 x 462	12
CP2442	564 x 1021	12
CP3220	762 x 462	12
CP4420	1072 x 462	12
CP5620	1351 x 462	12

PROTEK RACK ANGLES

Square- and tapped-hole rack angles fit into PROTEK single- and double-hinged cabinets.

BULLETIN: DWDH2

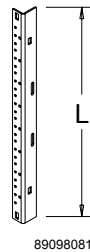

Standard Product

Catalog Number	L in./mm	Hole Type	Fits Cabinet Height in./mm	Rack Units
PTRA16T	16.12 409	Tapped	16.00	8
PTRA16S	16.12 409	Square	16.00	8
PTRA24T	23.12 587	Tapped	24.00	12
PTRA24S	23.12 587	Square	24.00	12
PTRA36T	35.32 897	Tapped	36.00	19
PTRA36S	35.32 897	Square	36.00	19
PTRA48T	45.57 1157	Tapped	48.00	26
PTRA48S	45.57 1157	Square	48.00	26
PTRA60T	59.07 1500	Tapped	60.00	32
PTRA60S	59.07 1500	Square	60.00	32

Notes